

Ozone Monitor

2B Technologies, Inc.



OPERATION MANUAL

[Model 202](#)

© Copyright 2001-2018, 2B Technologies, Inc.
All rights reserved.

Technical Support:
www.twobtech.com/techsupport
techsupport@twobtech.com
+1(303)273-0559

Contents

IDENTIFICATION RECORDS	iv
PRINTING HISTORY	v
WARRANTY STATEMENT	vi
WARNINGS	viii
1. OZONE MONITOR INTRODUCTION	1
1.1. Theory of Operation.....	1
1.2. Calibration Overview	3
1.3. Use of DewLine™ to Remove Humidity Interference	3
2. MODEL 202 OZONE MONITOR SPECIFICATIONS	4
3. INSTALLATION AND OPERATION	6
3.1. Shipping Box Contents.....	6
3.2. Installation of the Ozone Monitor.....	6
3.3. Measurement of the Zero Offset	7
3.4. Collecting Data from the Analog Output.....	7
3.5. Collecting Data over the Serial Port in Real Time.....	7
3.6. Data Averaging and Data Logging Using the Menu	9
3.7. Menu Definitions and Menu Tree	9
3.8. Selecting the Menu	10
3.9. To Log Data Using the Internal Data Logger	11
3.10. To Stop Logging Data Using the Internal Data Logger	12
3.11. To Transmit Logged Data to a Computer Using the Serial Port.....	12
3.12. To Log Data Using the SD Card.....	13
3.13. To Average Data	14
3.14. To Set the Calibration Parameters	14
3.15. To Set the Time and Date	16
3.16. To Change the Output Baud Rate.....	16
3.17. To Turn the Analog Inputs On and Off and Change the Analog Output Scaling Factor	16
3.18. To Turn the Display Light On and Off.....	17
3.19. To Change the Units for Internal Temperature, Pressure, and Ozone	17
3.20. To Test the Lamp Voltage and Precision	18
3.21. To Read the Number of Hours of Ozone Monitor Use	18
3.22. To Turn the Optional Lamp Heater On and Off.....	18
4. ACCESSING THE SERIAL MENU	19
5. MAINTENANCE	20
6. CALIBRATION	21
6.1. Introduction.....	21
6.2. Ozone Standards.....	21
6.3. Equipment Required.....	21
6.4. Instrument Preparation.....	22
6.5. Calibration Setup Preparation	22
6.5.1. Setup Check.....	23
6.5.2. Ozone Loss Test	23

6.5.3.	Linearity Check.....	23
6.5.4.	Intercomparison Test	24
6.6.	Calibration Procedure.....	24
6.6.1.	Instrument Preparation.....	24
6.6.2.	Measurement of Zero Air	24
6.6.3.	Measurement of Ozone Standards	24
6.6.4.	Calibration Curve	25
7.	PERIODIC ZERO AND SPAN CHECKS	26
8.	TROUBLESHOOTING	27
9.	LABELED INSTRUMENT PHOTOS	30
10.	PARTS LIST	35
11.	SERVICE LOG	36
	Appendix A: Using the 2B Technologies Display and Graphing Software	38

IDENTIFICATION RECORDS

Record the following information for future reference:

Unit serial number: _____

Warranty start date: _____
(date of receipt)

PRINTING HISTORY

This manual covers the Model 202 Ozone Monitor used for measurement of atmospheric ozone over a wide dynamic range extending from a limit of detection of 3.0 parts-per-billion by volume (ppbv) to an upper limit of 250 parts-per-million (ppmv). New editions of this manual are complete revisions that reflect updates to the instrument itself, as well as clarifications, additions and other modifications of the text.

Revision C	October 2005
Revision D	September 2008
Revision E	October 2009
Revision F	September 2010
Revision G	February 2011
Revision H	April 2015
Revision I (serial number 1858-1899).....	November 2016
Revision J (serial number 1900 and above)	January 2017
Revision J-2.....	April 2018
(Minor revision: update Section 2 Specifications table to give GPS detail.)	

TRADEMARKS & PATENTS

2B Technologies™, 2B Tech™, 2B™ and Ozone Monitor™ are trademarks of 2B Technologies, Inc.

CONFIDENTIALITY

The information contained in this manual may be confidential and proprietary, and is the property of 2B Technologies, Inc. Information disclosed herein shall not be used to manufacture, construct, or otherwise reproduce the goods disclosed herein. The information disclosed herein shall not be disclosed to others or made public in any manner without the expressed written consent of 2B Technologies, Inc.

© Copyright 2B Technologies, Inc.
All rights reserved.

WARRANTY STATEMENT

2B Technologies, Inc. warrants its products against defects in materials and workmanship. 2B Technologies will, at its option, repair or replace products that prove to be defective. The warranty set forth is exclusive and no other warranty, whether written or oral, is expressed or implied. 2B Technologies specifically disclaims the implied warranties of merchantability and fitness for a particular purpose.

Warranty Period

The warranty period is one (1) year from date of receipt by the purchaser, but in no event more than thirteen (13) months from original invoice date from 2B Technologies, Inc.

Warranty Service

Warranty Service is provided to customers via web ticket, email and phone support, Monday - Friday, from 9:00 a.m. to 5:00 p.m., Mountain Time USA. The preferred method of contacting us is through our web ticketing software at:

www.twobtech.com/techsupport

This way all technical staff at 2B Tech will be alerted of your problem and be able to respond. When you receive an email reply, please click on the Ticket link provided to continue to communicate with us directly over the internet. The web ticket approach to customer service allows us to better track your problem and be certain that you get a timely response. We at 2B Tech pride ourselves on the excellent customer service we provide.

You may also contact us by email at techsupport@twobtech.com or by phone at +1(303)273-0559. In either case, a web ticket will be created, and future communications with you will be through that ticket.

Initial support involves trouble-shooting and determination of parts to be shipped from 2B Technologies to the customer in order to return the product to operation within stated specifications. If such support is not efficient and effective, the product may be returned to 2B Technologies for repair or replacement. Prior to returning the product, a Repair Authorization Number (RA) must be obtained from the 2B Technologies Service Department. We will provide you with a simple Repair Authorization Form to fill out to return with the instrument.

Shipping

2B Technologies will pay freight charges for replacement or repaired products shipped to the customer site. Customers shall pay freight charges for all products returning to 2B Technologies.

Conditions

The foregoing warranty shall not apply to defects resulting from improper or inadequate maintenance, adjustment, calibration or operation by customer. Maintenance, adjustment, calibration or operation must be performed in accordance with instructions stated in the Ozone Monitor manual. Usage of maintenance materials purchased from suppliers other than 2B Technologies will void this warranty.

Limitation of Remedies and Liability

The remedies provided herein are the Customer's sole and exclusive remedies. In no event shall 2B Technologies be liable for direct, indirect, special, incidental or consequential damages (including loss of profits) whether based on contract, tort or any other legal theory. The Ozone Monitor manual is believed to be accurate at the time of publication and no responsibility is taken for any errors that may be present. In no event shall 2B Technologies be liable for incidental or consequential damages in connection with or arising from the use of the Ozone Monitor manual and its accompanying related materials. Warranty is valid only for the country designated on the 2B Technologies quote or invoice.

WARNINGS

ENGLISH

 **WARNING:**
Any operation requiring access to the inside of the equipment, could result in injury. To avoid potentially dangerous shock, disconnect from power supply before opening the equipment.

WARNING:
This symbol, , on the instrument indicates that the user should refer to the manual for operating instructions.

WARNING:
If this instrument is used in a manner not specified by 2B Technologies, Inc. USA, the protection provided by the instrument may be impaired.

ESPAÑOL

 **ATENCIÓN:**
Cualquier operación que requiera acceso al interior del equipo, puede causar una lesión. Para evitar peligros potenciales, desconectarlo de la alimentación a red antes de abrir el equipo.

ATENCIÓN:
Este símbolo, , en el instrumento indica que el usuario debería referirse al manual para instrucciones de funcionamiento.

ATENCIÓN:
Si este instrumento se usa de una forma no especificada por 2B Technologies, Inc., USA, puede desactivarse la protección suministrada por el instrumento.

FRANÇAIS

 **ATTENTION:**
Chaque opération à l'intérieur de l'appareil, peut causer du préjudice. Afin d'éviter un shock qui pourrait être dangereux, déconnectez l'appareil du réseau avant de l'ouvrir.

ATTENTION:
Le symbol, , indique que l'utilisateur doit consulter le manuel d'instructions.

ATTENTION:
Si l'instrument n'est pas utilisé suivant les instructions de 2B Technologies, Inc., USA, les dispositions de sécurité de l'appareil ne sont plus valables.

DEUTSCH

 **WARNHINWEIS:**
Vor dem Öffnen des Gerätes Netzstecker ziehen!

WARNHINWEIS:
Dieses, , auf dem Gerät weist darauf hin, daß der Anwender zuerst das entsprechende Kapitel in der Bedienungsanleitung lesen sollte.

WARNHINWEIS:
Wenn das Gerät nicht wie durch die Firma 2B Technologies, Inc., USA, vorgeschrieben und im Handbuch beschrieben betrieben wird, können die im Gerät eingebauten Schutzvorrichtungen beeinträchtigt werden.

ITALIANO

 **ATTENZIONE:**
Qualsiasi intervento debba essere effettuato sullo strumento può essere potenzialmente pericoloso a causa della corrente elettrica. Il cavo di alimentazione deve essere staccato dallo strumento prima della sua apertura.

ATTENZIONE:
Il simbolo, , sullo strumento avverte l'utilizzatore di consultare il Manuale di Istruzioni alla sezione specifica.

ATTENZIONE:
Se questo strumento viene utilizzato in maniera non conforme alle specifiche di 2B Technologies, Inc. USA, le protezioni di cui esso è dotato potrebbero essere alterate.

DUTCH

 **OPGELET:**
Iedere handling binnenin het toestel kan beschadiging veroorzaken. Om iedere mogelijk gevaarlijke shock te vermijden moet de aansluiting met het net verbroken worden, vóór het openen van het toestel.

OPGELET:
Het symbol, , geeft aan dat de gebruiker de instructies in de handleiding moet raadplegen.

OPGELET:
Indien het toestel niet gebruikt wordt volgens de richtlijnen van 2B Technologies, Inc., USA gelden de veiligheidsvoorzieningen niet meer.

CHINESE

 **警告:**
任何需要触及设备内部的操作可能造成人身伤害。为避免可能的触电危险，请在打开设备前切断电源。

警告:
这个符号 , 在仪器上表示用户应参考说明书上的操作指南。

警告:
如果仪器没有按照美国2B科技公司指定方式操作，仪器的保护性能会减弱。

JAPANESE

 **警告:**
機器の内部で操作する時、怪我できます。危険な衝撃を回避するために、機器を開ける前に、電源を切断してください。

警告:
機器でこの記号  を見れば、マニュアルを読んでください。

警告:
この機器は2Bテクノロジー会社、USAの指定でなければ、機器の保護が損なえます。

1. OZONE MONITOR INTRODUCTION

The 2B Technologies Ozone Monitor™ is designed to enable accurate measurements of atmospheric ozone over a wide dynamic range extending from a limit of detection of 3.0 parts-per-billion by volume (ppbv) to an upper limit of 250 parts-per-million (ppmv) based on the well-established technique of absorption of ultraviolet light at 254 nm. The Ozone Monitor™ is light weight (5.5 lb, 2.5 kg) and has a low power consumption (~7.2 watt) relative to conventional instruments and is therefore well suited for applications such as:

- vertical profiling using balloons, kites, remotely piloted aircraft, and other aircraft where space and weight are highly limited
- long-term monitoring at remote locations where power is highly limited
- urban arrays of ground-based detectors
- personal exposure monitoring for studies of health effects of air pollutants

1.1. Theory of Operation

Absorption of UV light has long been used for measurements of atmospheric ozone with high precision and accuracy. The ozone molecule has an absorption maximum at 254 nm, coincident with the principal emission wavelength of a low-pressure mercury lamp. Fortunately, few molecules found at significant concentrations in the atmosphere absorb at this wavelength. However, interferences, such as organic compounds containing aromatic rings, can occur in highly polluted air. Mercury vapor can be a significant interference inside buildings where mercury spills have occurred in the past and in the vicinity of certain mining operations.

Figure 1-1 is a schematic diagram of the ozone monitor. Ozone is measured based on the attenuation of light passing through a 15-cm long absorption cell fitted with quartz windows. A low-pressure mercury lamp is located on one side of the absorption cell, and a photodiode is located on the opposite side of the absorption cell. The photodiode has a built-in interference filter centered on 254 nm, the principal wavelength of light emitted by the mercury lamp. An air pump draws sample air into the instrument at a flow rate of approximately 1 L/min. A solenoid valve switches so as to alternately send this air directly into the absorption cell or through an ozone scrubber and then into the absorption cell. The intensity of light at the photodiode is measured in air that has passed through the ozone scrubber (I_o) and air that has not passed through the scrubber (I). Ozone concentration is calculated from the measurements of I_o and I according to the Beer-Lambert Law:

$$C_{O_3} = \frac{1}{\sigma l} \ln\left(\frac{I_o}{I}\right) \quad (1)$$

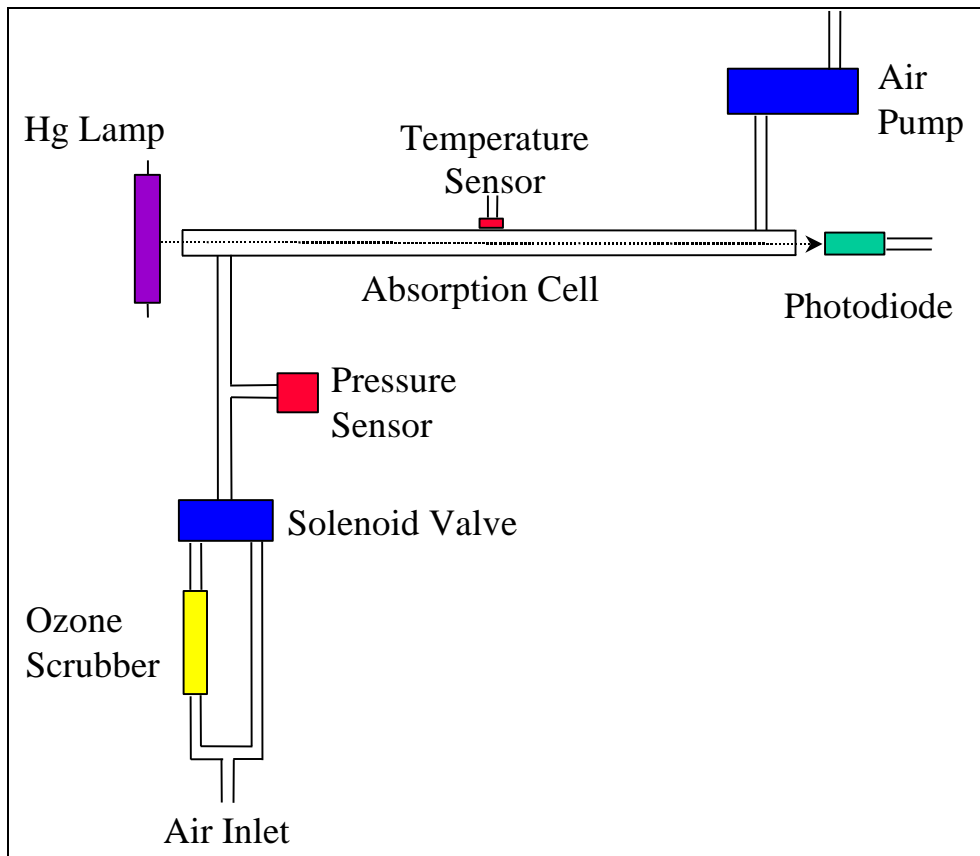

FIGURE 1-1. Schematic diagram of the ozone instrument.

where l is the path length (15 cm) and σ is the absorption cross section for ozone at 254 nm ($1.15 \times 10^{-17} \text{ cm}^2 \text{ molecule}^{-1}$ or $308 \text{ atm}^{-1} \text{ cm}^{-1}$), which is known with an accuracy of approximately 1%. The 2B Technologies instrument uses the same absorption cross section (extinction coefficient) as used in other commercial instruments.

The logarithm of equation 1 is calculated in the microprocessor of the instrument with sufficient accuracy to provide five orders of dynamic range; ozone mixing ratios are measured up to 250 ppbv. The shorter path length of the 2B Tech Model 202 Ozone Monitor also contributes to the wide dynamic range, which is limited at the high end by the absorption beginning to become optically thick (base 10 optical absorbance = 0.2).

The pressure and temperature within the absorption cell are measured so that the ozone concentration can be expressed as a volume mixing ratio in ppbv, ppmv, or pphmv. The mixing ratio can also be expressed as micrograms per cubic meter ($\mu\text{g m}^{-3}$) or milligrams by cubic meter (mg m^{-3}). The instrument displays and records the cell temperature and pressure in addition to the ozone mixing ratio. The cell pressure is displayed and logged in units of either torr or mbar and the cell temperature in units of either °C or K.

1.2. Calibration Overview

In principle, the measurement of ozone by UV absorption requires no external calibration; it is an absolute method. However, non-linearity of the photodiode response and electronics can result in a small measurement error. Therefore, each instrument is compared with a NIST-traceable standard ozone spectrophotometer in the laboratory over a wide range of ozone mixing ratios. These results are used to calibrate the Ozone Monitor with respect to an offset and slope (gain or sensitivity). The corrections for offset and slope are recorded in the instrument Birth Certificate and on a calibration sticker that can be viewed by removing the top cover of the instrument. These calibration parameters are entered into the microprocessor prior to shipment. The user may change the calibration parameters from the front panel or the serial menu if desired (see Sections 3.14 and 4). The offset may drift due to temperature change or chemical contamination of the absorption cell. As discussed below (Section 3.3 and Section 7), an accurate offset correction can be measured from time to time using the ozone scrubber supplied with the instrument. It is recommended that the instrument be recalibrated at least once annually and preferably more frequently. The calibration procedure is described in detail in Section 6.

1.3. Use of DewLine™ to Remove Humidity Interference

Not shown on Figure 1-1 is the DewLine™, which serves to make the humidity entering the detection cell identical during I and I_o measurements. Please see our website for a technical discussion of the DewLine™ and its importance to ozone measurements: www.twobtech.com/dewline.htm. Briefly, water vapor adsorbed to the inner wall of the detection cell changes the reflectivity of the cell. If humidity is not the same during I and I_o measurements, an offset in the ozone measurement will occur and can be up to several tens of ppb for sudden changes in ambient humidity. The offset will change with time as the internal ozone scrubber equilibrates with water vapor. Even for fixed-site ozone monitors, an offset measurement error will occur if the instrument is zeroed with dry tank air and then used to measure ozone in humid air. The DewLine™ solution to this often-ignored problem is unique to 2B Tech instruments.

2. MODEL 202 OZONE MONITOR SPECIFICATIONS

Measurement Principle	UV Absorption at 254 nm
Federal Equivalent Method (FEM)	Yes, EQOA-0410-190
Linear Dynamic Range	0 ppb to 250 ppm
Resolution	0.1 ppb
Precision (1σ; rms noise)	Greater of 1.5 ppb or 2% of reading (in 10-s measurement mode)
Limit of Detection (2σ)	3.0 ppb (in 10-s measurement mode)
Accuracy	Greater of 1.5 ppb or 2% of reading
NIST-Traceable Calibration	Yes
Measurement Interval	10 s (Data averaging options: 1 min, 5 min, 1 hr)
Flow Rate (nominal)	~1 Liter/min
Flow Rate Requirement	>0.6 L/min
Baseline Drift	<2 ppb/day <5 ppb/year
Sensitivity Drift	<1%/day <3%/year
Measurement Time, Frequency	10 s, 0.1 Hz
Response Time, 100% of Step Change	20 s, 2 points
Averaging Times	1 min, 5 min, 1 hr
Ozone Units	ppb, pphm, ppm, $\mu\text{g m}^{-3}$, mg m^{-3}
Pressure Units	mbar, torr
Temperature Units	$^{\circ}\text{C}$, K
T and P Corrected	Yes
Operating Temperature Range	0 to 50 $^{\circ}\text{C}$ standard; optional -20 to 50 $^{\circ}\text{C}$ with low temperature modifications (pump and lamp heater cold-weather package)

Operating Altitude Range	~0-13.5 km (150-1,013 mbar) standard; optional ~0-25 km (30-1,013 mbar) with upgraded pressure sensor
Power Requirement; Supplied by battery or 110/220 VAC Power Pack	11-14 V DC or 120/240 VAC, nominally 600 mA at 12 V, 7.2 watt (6.2 watt with cell heater unplugged)
Size	3.7 × 8.5 × 11.8 inches (9.5 × 21.5 × 30 cm)
Weight	5.5 lb (2.5 kg); 2.8 lb (1.3 kg) without instrument case
Internal Data Logger Capacity	16,383 lines (10-s meas. = 1.9 days; 1-min avg = 11 days; 5-min avg = 1.9 mo; 1-hr avg = 1.9 yr)
SD Card Logger Capacity	Minimum 2 GB (> 5-year capacity for 10-s measurement mode)
Analog Inputs for Internal Logging of Other Instruments	3 Analog Inputs, 0-2.5 V (for example, could log external T, P, and RH)
Data Outputs	RS232, 0-2.5 V Analog, LCD Display; External USB Converter (Optional 4-20 mA current; request quote)
Data Transfer Baud Rates	2400, 4800, 19200
Output Ranges	User-Defined Scaling Factor in Menu
DewLine™	Yes
Flow Meter	Yes
Options	Battery; External Particle Filter, Serial-to-USB Converter; Bluetooth; 4-20 mA Current Output; GPS (for 10-s data mode and above); Cold-Weather Package (pump, lamp heater); High-Altitude Upgrade (pressure sensor); Extra-Long-Life, Low-Temperature Internal Air Pump; Rack-Mount Case
Upgradable to Model 205 Dual Beam	Yes

3. INSTALLATION AND OPERATION

Please read all the following information before attempting to install the Ozone Monitor. For assistance, please call 2B Technologies at (303) 273-0559.

PLEASE NOTE:

- **Save the shipping carton and packing materials that came with the Ozone Monitor.**
- **If the Ozone Monitor must be returned to the factory, pack it in the original carton.**
- **Any repairs as a result of damage incurred during shipping will be charged.**

3.1. Shipping Box Contents

Open the shipping box and verify that it contains all of the items on the shipping list. If anything is missing or obviously damaged, contact 2B Technologies immediately.

3.2. Installation of the Ozone Monitor

To operate the Ozone Monitor, connect it to an external power source and turn the instrument on by flipping the front panel switch. The instrument requires a 12 V DC source which can be supplied by: 1) the 110-220 V AC power adapter, 2) a cigarette lighter adapter plugged into a 12 V DC source such as found in an automobile or many light aircraft, or 3) a 12 V battery. The source can be in the range 11-14 V DC without any detrimental effects on the measurement. When using a battery, be certain to attach the positive (red) and negative (black) wires correctly. A circuit breaker and diode are installed on the circuit board in case of an electrical short or incorrect battery attachment. If activated, the breaker will reset itself after a few minutes.

Lead-acid batteries are available from numerous manufacturers in a wide range of sizes and amp-hour ratings. The larger of these, such as those for automobiles or boats, will supply power for up to several days. Battery packs in the correct voltage range may be constructed from nickel-cadmium (rechargeable) or lithium (lightweight but not rechargeable) batteries for operation for a few hours. Battery options available through 2B Technologies may be found on our webpage: www.twobtech.com.

Once turned on, the instrument will display the version number of the software installed on the microprocessor followed by a display of the time and date. After a few seconds, the instrument will start displaying readings for ozone and the temperature and pressure of the absorption cell. The first dozen readings (requiring about two minutes) will be spurious, with large positive and negative swings, due to the rapid warmup of the lamp and electronics. Also, ozone readings may be inaccurate during the 10-20 minutes required for the lamp, photodiode, and internal temperature of the absorption cell to stabilize.

Inlet tubing may be attached to the ¼ inch nylon Swagelok fitting on the back of the instrument. The inlet tubing should be made of PTFE (Teflon®), PFA, or some other inert material that does not destroy ozone and that does not desorb plasticizers and other organics that can contaminate the flow path. The length of tubing should be kept as short as possible (not more than a few feet) to minimize ozone destruction. Tygon®, polypropylene (which may look like Teflon®), and metal tubing should not be used. Teflon-lined Tygon® tubing, which is used inside the 2B Technologies instrument, provides the flexibility of Tygon® with the inertness of Teflon®. A Teflon® inlet filter is highly recommended to prevent internal contamination of the tubing and absorption cell by particulate matter. The filter should be tested for ozone loss by measuring ambient ozone with and without the filter attached. Tubing, filters, and filter holders are available through 2B Technologies. See our website: www.twobtech.com.

If the instrument is being flown, the inlet should not point into the wind, because the resulting pressure fluctuations will result in a noisy signal. Although the instrument compensates for temperature drift, if strong temperature fluctuations are expected, as in vertical profiling applications using balloons, the instrument should be placed in a thermally insulated box

3.3. Measurement of the Zero Offset

The electronic zero of the instrument may be measured by attaching an ozone destruction cartridge to the air inlet for a period of 5-10 minutes (see Section 7 of this manual). For an accurate measurement, the instrument must have been turned on long enough for the internal temperature to stabilize. The observed offset, which can amount to a few ppbv, can be corrected by changing this calibration parameter from the front panel, as described below, or by correcting the data at a later time.

3.4. Collecting Data from the Analog Output

The data may be logged in real time using a data logger attached to the BNC analog output. The range of the analog output is 0-2.5 V. The output is scaled according to a sensitivity you define in the menu. For example, you may define 1V = 100 ppbv. In that case, the maximum output is 250 ppbv. There is a small positive offset, typically 2 mV in the analog output, but this offset varies from instrument to instrument. The offset can be measured by simultaneously observing the panel display and measuring the analog output with a voltmeter.

3.5. Collecting Data over the Serial Port in Real Time

To transmit data to a computer over the serial port in real time, connect the Ozone Monitor to the serial port of the computer using the 9-pin cable provided. Note that this is a “straight-through” female-female serial cable. A “cross-over” cable will not work. Start your data acquisition software, preferably using the 2B Technologies Display and Graphing Software (available as a free download from the 2B Tech website, <http://www.twobtech.com/downloads.htm>). See Appendix A of this manual for information about working with this software. Other terminal emulation software

such as HyperTerminal (a program provided with earlier versions of Windows) or [Tera Term](#) may be used as well.

The ozone mixing ratio (ppbv), internal cell temperature (K or °C), cell pressure (torr or mbar), volumetric flow rate (cc/min), values of three external analog inputs in volts (if activated from the menu), date, and time are sent as comma-delimited ASCII text to the serial port (2400, 4800 or 19,200 baud; 8 bits; no parity; 1 stop bit) every ten seconds, 1 minute, 5 minutes, or 1 hour, depending on the averaging time selected from the microprocessor menu. Time is provided in 24-hour (military) format, and the date is given in European style (day/month/year).

With analog inputs activated from the menu, a typical data line might read:

```
67.4,35.3,980.6,850,1.3876,2.3143,0.1875,15/10/16,18:31:27
```

where:

Ozone = 67.4 ppbv

Cell temperature = 35.3°C (may be expressed in K if chosen from menu)

Cell pressure = 980.6 mbar (may be expressed in torr if chosen from menu)

Volumetric flow rate = 850 cc/min

Analog input A = 1.3876 volts

Analog input B = 2.3143 volts

Analog input C = 0.1875 volts

Date = October 15, 2016

Time = 6:31:27 pm

The three external inputs are omitted from the data line if they are turned off using the menu, as described in Section 3.17 below. The analog inputs allow measurements made by other instruments to be transmitted to a computer simultaneously with those of ozone and the time and date stamp; these inputs may also be logged in the instrument's internal memory, as described below. Examples of external measurements that are commonly made along with ozone are external temperature, pressure, and relative humidity, but the outputs of any instrument may be input to the Ozone Monitor. The analog inputs may range from 0 to +2.5000 volts and are measured with an accuracy of approximately ± 0.0001 volt. **Caution: An input voltage greater than +5.0 volts or less than -0.3 volts may permanently damage the instrument.**

If the Ozone Monitor has been set to the "log data" mode, the output serial data line will be preceded by the log number; e.g.,

```
2893,67.4,35.3,980.6,850,1.3876,2.3143,0.1875,15/10/16,18:31:27
```

where 2893 is the log number.

In addition to data lines, messages are written to the serial port when logging is begun or ended, when transmission of data from the logger is begun and ended, when data collection is interrupted (e.g., due to a power failure), and when the averaging time is changed.

3.6. Data Averaging and Data Logging Using the Menu

When first turned on, the instrument will start making measurements at a rate of once every 10 s. Data, along with up to three external voltages, may be logged in the internal data logger. Up to 16,383 data lines containing log number, ozone mixing ratio, internal temperature, internal pressure, volumetric flow rate, date, and time may be stored in internal memory, corresponding to an operational time of 1.9 days. Averaging times of 1 min, 5 min, and 1 hr also may be selected from the menu, thereby allowing the instrument to operate for 1.6 weeks, 1.9 months and 1.9 years, respectively, before filling the memory. The maximum number of data lines is halved if the three analog inputs are logged along with the other data.

3.7. Menu Definitions and Menu Tree

The Menu is accessible from the LCD display of the Model 202 Ozone Monitor. Menu options are defined in the table below and shown in the drawing on the next page.

Dat: Data Menu
 Xmt: Transmit stored logged data
 End: End data logging
 Log: Start data logging and write over existing logged data
 SD: Transmit data to SD data logger

Avg: Averaging Menu
 10s: 10 seconds, **1m:** 1 minute, **5m:** 5 minute, **1h:** 1 hour

Cfg: Configurations Menu
 D/T: Date and Time Setting
 Cal: Calibration Menu
 Fm: Flow Meter calibration menu
 O3: Ozone measurement calibration menu

I/O: Input and Output Menu
 Bdr: Baud Rate selection menu
 Ext: External input and output menu
 V_In: Voltage Input menu
 V_Out: Voltage Output menu
 Hrs: Display number of hours of use
 LCD: LCD back light menu

Unt: Units menu
 T/P: Temperature and Pressure units selection
 O3: Ozone units selection

Lmp: Lamp test selection

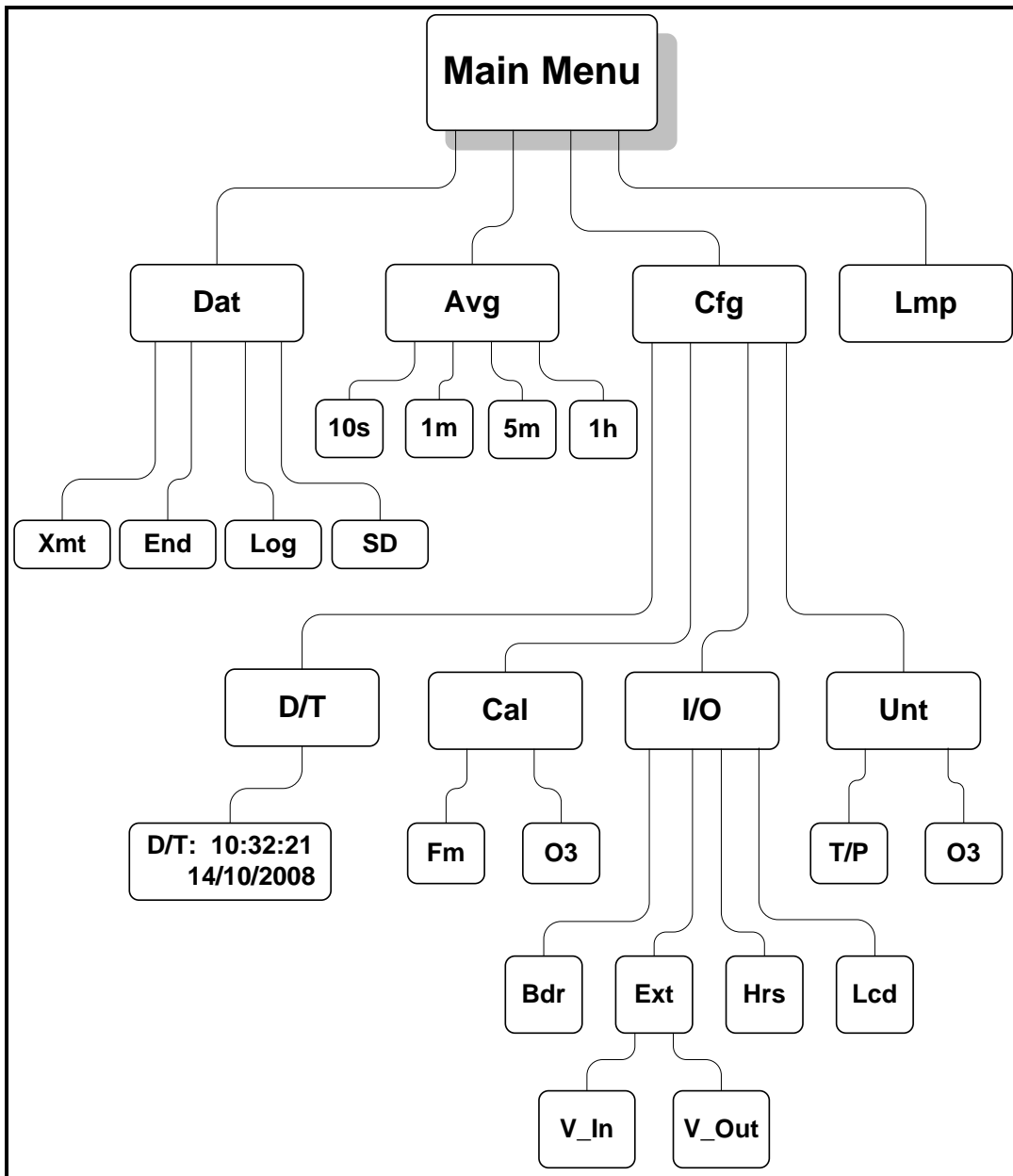

3.8. Selecting the Menu

The **Main Menu** is accessed using the Select button on the front panel of the instrument. To reach the menu, hold in the Select button until the display shows: **Menu**

Then, release the button. The panel will now display:

Menu
Dat Avg Cfg Lmp ←

where **Dat**, **Avg**, **Cfg**, and **Lmp** are submenus that may be selected. A blinking cursor will show across the **D** of the **Dat** submenu. The Select button may be rotated

clockwise or counterclockwise to move the cursor under the first letter of one of the other submenus. To select a particular submenu, move the cursor under the first letter of the submenu and click (press in) the Select button. To exit the Main Menu and begin making measurements again, select and click on the right arrow (←).

3.9. To Log Data Using the Internal Data Logger

Select the **Dat** submenu from the Main Menu using the Select button. The display will now show:

Data Menu
Xmt Log End SD ←

To start logging data using the internal data logger, rotate the Select switch to move the cursor to **Log** and click to select the logging mode. You will then be asked whether you want to overwrite the data stored in the logger:

Overwrite Data?
No Yes ←

If you select yes and start logging, all data previously stored in the logger will be irretrievably lost.

Caution: If you have data in the logger that you want to keep, be sure to download it before starting logging.

If you are ready to start logging, then select **Yes** by moving the cursor under **Yes** and clicking. Either selection will return you to the **Main Menu**. To start data acquisition, select ← and click.

The Ozone Monitor will then alternately display every five seconds: 1) the ozone measurement and log number and 2) the ozone measurement, internal temperature, and internal pressure. For example, the display might read:

O3= 56.7 ppb
T=305.6 P=730.4

where the ozone value is the most current ozone measurement, and T and P are the cell temperature and pressure (in units of K and torr, in this case). After 5 seconds (midway between the next 10-s measurement cycle), the display will be replaced by:

O3= 56.7 ppb
Log= 193:0

where **O3** is the ozone value most recently written to the logger, and the log number is 193.

If averaging has been selected (see **To Average Data**, Section 3.13), then the above display will be replaced by:

Avg O3=56.7 ppb
Log= 193:4

Again 193 refers to the most recent log number. The “4” in 193:4 refers to the number of 10-s data points that have been measured so far for inclusion in the next average to be displayed and logged. If 10-s averaging is used (i.e., no averaging), this number will always be 0. If 1-min averaging is used, this number will increment from 0 to 5; for 5-min averaging, the number will increment from 0 to 29; and for 1-hr averaging, it will increment from 0 to 359. This number is displayed so that the user will know how many more 10-s measurements need to be made before a new average is displayed and logged.

If there is a power failure while the instrument is in the logging mode, logging will resume after power is restored. A note of

Data Interruption

will be written to the logger prior to writing the first new data line. In the case of a power failure, 1 data line may be lost.

The instrument can accommodate multiple data interruptions due to power failures. For example, one can purposely switch the instrument off, move to another location and restart logging simply by turning the instrument back on and the data will be logged with the correct date and time.

3.10. To Stop Logging Data Using the Internal Data Logger

Hold the Select button down to obtain the **Menu**. Go to the **Dat** submenu by clicking on **Dat**. Choose and click on the **End** function. This will end data logging. You may now transmit the data to a computer by clicking on **Xmt** (see below). Alternatively, you may return to the **Menu** by clicking on ←. The stored data will reside in memory (even when new measurements are being made) and can be transmitted using the **Xmt** function as often as you like. However, all stored data are lost once logging is started again using the **Log** function. Thus, you should always transmit your data to a computer before restarting logging.

If you fail to **End** logging prior to transmitting the data using the **Xmt** function, the instrument will automatically execute the **End** function for you prior to transmitting the data.

3.11. To Transmit Logged Data to a Computer Using the Serial Port

Connect the serial port of the instrument to the serial port of your computer using the cable provided. If your computer does not have a serial port, you can use the USB port by means of a serial-to-USB adapter. Such adapters are available in most computer stores or can be supplied by 2B Tech.

Start your data acquisition software, such as the 2B Technologies Display and Graphing Software, which is available for free download from 2B Tech’s website, <http://www.twobtech.com/downloads.htm>. See Appendix A of this manual for information about working with this software.

Alternatively, other terminal emulation software such as Hyperterminal (available on earlier versions of Windows® platforms, usually in Start/All Programs/Accessories/Communications/Hyper Terminal) or [Tera Term](#) may be used as well. A disadvantage of Hyperterminal is that it has a 500-line buffer limit. However, all of these programs may be used to log an unlimited number of data lines to a file on your computer. For more details see our Tech Note #007 here:

http://www.twobtech.com/tech_notes/TN007.pdf

Hold down the Select button to obtain the **Main Menu**. Go to the **Dat** submenu by clicking on **Dat**. Next, click on **Xmt**. The message “Logged Data” will be written to the serial port, followed by a carriage return and all of the lines of logged data. After all data are transmitted, the message “End Logged Data” and a carriage return are written. After transmission is complete, you can return to any position in the menu or resume ozone measurements. The logged data continues to be available for transmission until a new data log is started.

3.12. To Log Data Using the SD Card

2B Technologies provides a SD card logger with the Model 202 Ozone Monitor, along with an SD card and an SD card reader. When inserted into the instrument (bottom left of the Ozone Monitor’s front panel), the SD card automatically begins to collect and store data. (The internal data logger described in Section 3.9 will also be logging data if logging has been selected from the **Dat** submenu.) With analog inputs activated from the menu, the data are saved to a .txt file in the following format:

67.4,35.3,980.6,850,1.3876,2.3143,0.1875,15/10/16,18:31:27

where

Ozone = 67.4 ppbv

Cell temperature = 35.3°C (may be expressed in K if chosen from menu)

Cell pressure = 980.6 mbar (may be expressed in torr if chosen from menu)

Volumetric flow rate = 850 cc/min

Analog input A = 1.3876 volts

Analog input B = 2.3143 volts

Analog input C = 0.1875 volts

Date = October 15, 2016

Time = 6:31:27 pm

Data files on the SD card are named “LOG01.txt,” “LOG02.txt,” etc. Note that the SD card contains a LOGCON.txt file that should not be modified or deleted.

Data logging on the SD card will continue until either (1) the user ends data logging from the LCD menu, or (2) the instrument is powered off. A new data file is begun each time the instrument is powered on.

To eject the SD card, first save the file through the LCD menu (**Menu / Dat / SD**). Then eject the SD card by pushing it in to activate the spring mechanism. Insert the SD card into an SD card reader (one is supplied by 2B Technologies with the instrument) to download the data to your computer.

Important: Do not remove the SD card or power off the instrument without first saving the data through the front panel LCD menu. This minimizes the risk of losing any lines of the data. Up to 5 lines of data could be lost if the SD card is removed without first saving the data.

The Model 202 Ozone Monitor is compatible with SD and SDHC memory cards. We recommend using the SD cards available on the 2B Technologies website (<http://twobtech.com/parts-online.html>). Prior to first use, SD cards must be formatted to FAT32. As mentioned above, an SD card and SD card reader are supplied with the Model 202 Ozone Monitor.

See [Technical Note 036](#) for more information about logging and reading data via the SD card.

3.13. To Average Data

The Model 202 Ozone Monitor has several options for obtaining and averaging measurements. Hold down the Select button to obtain the **Menu**. Select and click on **Avg** to obtain the **Avg** menu:

Avg Menu
10s 1m 5m 1h ←

Use single clicks to move the cursor to **10s**, **1m**, **5m**, or **1h** for averaging times of 10 s (no averaging), 1 min, 5 min or 1 hr averaging, respectively. Then click on the averaging time you want to use. To return to the Main Menu, click on ←. To exit the Main Menu and start acquiring data, click on ← again.

While in averaging mode, the current 10-s measurement is displayed alternately with the average value, as discussed above.

Averaged data may be logged, thereby greatly extending the length of time that the internal data logger can be used.

3.14. To Set the Calibration Parameters

The instrument is calibrated at the factory where slope and offset parameters are entered into the instrument's memory. These preset calibration parameters are given in the instrument's Birth Certificate and recorded on the calibration sticker viewable with the top cover removed. However, the calibration parameters may be changed by

the user (see Section 6). For example, it may be desirable to provide a positive offset by a known amount (e.g., 10 ppbv) if the analog output is being used for external data logging since the analog output does not go negative below zero ppbv. Because of noise and/or an inherent offset, some measured values will be below zero at very low ozone mixing ratios or while zeroing the instrument with an external scrubber. Also, the instrument zero may drift by a few ppbv over time. For this reason, frequent zeroing of the instrument using an external ozone scrubber to determine the offset is recommended (see Section 7). Any change in the slope (gain) of the instrument is likely due to a serious problem such as contamination, an air leak, obstruction of air flow, or loss of catalytic activity by the internal ozone scrubber, but it also can be adjusted. Once the zero of the instrument is corrected, the slope may be adjusted so that the instrument readout agrees with a standard ozone source or with the readout from another instrument whose calibration is considered to be accurate.

To change the calibration parameters, select **Cfg** from the **Main Menu**:

Cfg Menu
D/T Cal I/O Unt ←

Now use the rotary select switch to select and click on **Cal**. The following submenu will appear:

Cal Menu
Fm O3 ←

Selecting **Fm** will display the Flow meter calibration factor as in the following example:

Fm Cal Menu
Fm= 0.87 ←

The internal flow meter is calibrated at the factory during the production of the ozone monitor. This is a multiplicative factor that will increase the flow rate if you increase the value. Adjust this value to correct the flow value when comparing it to a calibrated volumetric flow meter connected to the inlet of the instrument.

By selecting **O3**, the following submenu with the values of the current calibration parameters will then appear:

O3 Cal Menu
Z=-2 S=1.01

Here **Z** is the offset applied (in this case -2 ppbv) and **S** is the slope applied (in this case 1.01). The value of **Z** is added to the measured ozone value, and the value of **S** is then multiplied by the measured ozone value. For example, if the instrument reads an average of 3 ppbv with the external scrubber in place, the value of **Z** should be set to -3 . If after correction for the zero, the instrument consistently reads 2% low, the value of **S** should be set to 1.02.

When the **Cal Menu** first appears, the **Z** will be underlined with a cursor. You may rotate the Select switch to choose the calibration parameter **S** or **Z**. A single click on **S** or **Z** will select that parameter for change and activate a blinking cursor. Once **S** or **Z** is selected, its value can be changed by rotating the Select switch to the left or right.

After choosing the desired value, a single click turns off the blinking cursor and allows you to scroll to the other parameter or to ← to exit the submenu. Once the values of **Z** and **S** are set, clicking on ← will return the display to the **Cfg** menu, and another click on ← will return to the **Main Menu**. The calibration parameters reside in non-volatile memory and are not affected by power failures.

3.15. To Set the Time and Date

From the **Main Menu**, select the **Cfg** submenu. Next, select the **D/T** submenu. The display will read, for example:

D/T: 14:32:21 ←
17/10/2016

meaning that it is 21 seconds after 2:32 p.m. on October 17, 2016 (military time and European date). To change a number in the date and time, rotate the Select switch to underline the numeral you want to change. A single click then causes a blinking cursor to cover that numeral. The number can then be changed by rotating the Select switch. Once the number is correct, click on the Select switch to turn off the blinking cursor. You may now rotate the Select switch to choose another numeral to change. Once the time and date is correct, clicking on ← will set the internal clock to that time and return the display to the **Cfg** menu. As in setting a digital watch, the seconds should be set in advance of the real time since the clock starts to run again only when the set time is entered; in this case by clicking on ←.

3.16. To Change the Output Baud Rate

From the **Cfg** submenu, select **I/O** to give the input/output menu, for example:

I/O Menu
Bdr Ext LCD ←

Selecting **Bdr** and clicking allows you to change the baud rate used for data transmission. The choices are 2400, 4800, and 19200 bps. The submenu appears as:

2400 4800 19200 ←

After clicking on a chosen baud rate, use ← to return to the **I/O** menu.

3.17. To Turn the Analog Inputs On and Off and Change the Analog Output Scaling Factor

Choosing **Ext** from the **Cfg / I/O Menu** allows you to turn the analog inputs on and off and to set the scaling factor for analog outputs:

Ext Menu
V_IN V_OUT ←

The two submenus allow one to turn the analog inputs on and off (**V_IN**) and to change the scaling factor for the analog voltage output (**V_OUT**).

Analog Inputs. To turn the three analog inputs on or off, select the **V_IN** submenu. If the analog voltage inputs are turned on you will see:

VIN Menu
Voltage In=ON ←

You may use the Select switch to toggle between **ON** and **OFF**. If no analog inputs are being used, it is advantageous to turn the analog inputs off in order to increase the number of data lines that can be logged in the internal data logger and to reduce clutter in the output data lines sent via the serial port.

Analog Outputs. An analog output is provided via a BNC connector at the back of the instrument for those who want to record their ozone concentration data with a chart recorder or external logger. The full scale of the analog output is 2.5 V. To change the analog output voltage scaling factor, select **V_OUT** from the **Ext** Menu:

VOUT Menu
1V= 00200 ppb ←

In this example, the output scaling factor is set as 1 Volt = 200 ppbv. Since the maximum output voltage is 2.5 V, the maximum output concentration in this case is 500 ppbv, and 1 ppbv will provide an output of 5 mV. You can use the select switch to change the scaling factor to the value of your choice by selecting and changing the individual digits in the scaling factor.

3.18. To Turn the Display Light On and Off

Selecting **LCD** from the **Cfg / I/O** submenu allows you to turn the light of the front panel display on and off. To conserve power, use the Select switch to set the **LCD** submenu to **OFF**.

3.19. To Change the Units for Internal Temperature, Pressure, and Ozone

From the **Cfg** menu, select **Unt** to give the following submenu, for example:

Units Menu
T/P O3

To change the units of temperature or pressure, rotate the Select switch until it is under the **T** or **P** and push to select. Temperature units may be selected as either Kelvin (**K**) or Celsius (**C**) by first clicking to obtain the blinking cursor and then rotating the Select switch to obtain the desired units. Pressure units may be selected as either **torr** or **mbar**. A click on ← returns the display to the **Unt** submenu. To change units of ozone, rotate the Select switch until it is under the **O3** and push to select. Move the cursor until it is under the first letter of the units, and push to select. Rotate the Select switch to scroll through the choices of units, and push to select the desired setting. A click on ← returns the display to the **Unt** submenu.

3.20. To Test the Lamp Voltage and Precision

A diagnostic lamp test is provided in the **Lmp** submenu of the main menu. Before the lamp test begins, “Pump On or Off?” is displayed. Turning the pump off during the lamp test is recommended because it eliminates any noise associated with air flow in order to better focus the test on the lamp stability. Comparing the results from testing with the pump off and with the pump on can help determine the source of noise and whether to clean the instrument or possibly replace the lamp. If the noise is greater with the pump on, this is a good indication that the flow path needs to be cleaned and the ozone scrubber replaced.

During the lamp test, the instrument measures the “effective” ozone concentration in the detection cell without switching the solenoid valve on and off. This is an electronic zero and should after a few readings settle down to \pm a few ppbv. If this value is outside the range -9 to +9, the instrument may not be operating correctly. The display also gives a standard deviation of the electronic zero. For best results, the standard deviation should be not greater than ± 2.5 . Note that because less averaging is involved, this is not equal to the overall precision of the instrument; it is a diagnostic test of lamp fluctuations. The lamp test also measures and outputs the voltage level of the detector.

For best performance the voltage should be in the range 0.7-2.0 volts. For a detector voltage less than about 0.7 volts, the data may be noisy due to insufficient light intensity to make precise measurements. If the voltage is zero, the lamp is not ignited and may have burned out. For voltages above 2.5 volts, the A/D converter is saturated and the measured ozone value will always be zero. This could happen if the instrument is very hot so that the lamp output is too bright.

To exit the **Lmp** test mode, hold in the Select switch and release to return to the **Main Menu**.

3.21. To Read the Number of Hours of Ozone Monitor Use

The instrument keeps track of the total number of hours of use. This is helpful for determining when the instrument should be serviced, a pump replaced, etc. To read the number of hours of operation, choose **Menu / Cfg / I/O / Hrs**.

3.22. To Turn the Optional Lamp Heater On and Off

If the Cold-Weather Option has been purchased, the lamp has a heater. This heater can be toggled by use of the serial commands (see Section 4).

4. ACCESSING THE SERIAL MENU

Measurements and logging tasks can be accessed via the serial port or the USB using the [2B Technologies Display and Graphing software](#) (see Appendix A for information on downloading and working with this free software) or a terminal emulator such as [Tera Term](#) or HyperTerminal running on an attached computer. Commands can be sent using the terminal emulator set with the properties listed in the Section 3.5 of this manual entitled “Collecting Data over the Serial Port in Real Time.” Listed below are the lower-case letters that are commands for performing certain operations while the instrument continues to measure:

- l** Start logging and write over existing logged data
- t** Transmit logged data
- e** End logging
- h** Output serial data line header
- m** Serial menu

If the letter **m** is sent as a command, **menu>** will be displayed in the terminal emulator window. When the serial menu is accessed, the instrument is no longer making measurements; it is waiting for the next command to be entered. The following is the list of menu items accessible from this point:

- l** Start logging and write over existing logged data
- t** Transmit logged data
- e** End logging
- h** Output the serial header
- b** Ends current file being written to external data logger (avoids losing data that are still in the buffer)
- a** Display list of possible averaging times and the number that must be entered to change to the desired averaging time
- z** Display current zero calibration setting and wait for new setting followed by a carriage return
- s** Display current slope calibration setting and wait for new setting followed by a carriage return
- f** Display current flow calibration factor and wait for new setting followed by a carriage return
- c** Clock menu, display current date and time and wait for **d** or **t** to be entered
 - d** Asks to enter date in DDMMYY format
 - t** Asks to enter time in HHMMSS format
- p** Perform lamp test with pump on
- u** Perform lamp test with pump off
- d** Turn the LCD backlight on
- g** Turn the LCD backlight off
- ?** Output the help menu
- x** Exit menu and return to measuring

If the instrument is equipped with the cold-weather option, two additional commands are available:

- k** Activates the Lamp Heater connected to J23
- j** Deactivates the Lamp Heater connected to J23

5. MAINTENANCE

The Model 202 Ozone Monitor is designed to be nearly maintenance free. The only components that require routine maintenance are the ozone scrubber, which should be changed at least once every six months of operation, and the air pump, which has rated lifetime of ~20,000 hours of operation. Other user-serviceable components include the lamp, clock battery, and solenoid valve, which are easily replaced should they fail. In addition, the inlet filter (user supplied) should be changed as recommended by the filter manufacturer.

The Model 202's quiet, long-life air pump has a lifetime specified by the manufacturer to be in the range of about 20,000 hours depending on environmental factors. This corresponds to over 2 years of continuous operation. The pump selected for use is based on several years of experience with different pump manufacturers and models.

Pump Options

- An internal extra-long-life, low-temperature air pump is available as an upgrade if pump lifetime and/or working at low temperatures are the main concerns.
- A Low-Power Option is available if power is the main concern. The pump configuration for this Option uses a different internal pump and backup (as was used in earlier versions of the Model 202, serial no. 1899 and below). This pump consumes less power but is louder and has a lower lifetime (~5,000 hours). With the Low-Power Option, the SD data logger is also disabled to save power. The Model 202 with the Low-Power Option consumes about 2 watts less than the standard Model 202.

A wide range of Technical Notes are provided on the 2B Tech website. The complete list with links may be found at (clickable link):

www.twobtech.com/tech_notes.htm

These Tech Notes are continuously updated and new ones created. Tech Notes specific to maintenance and repairs may be downloaded from (clickable links from this pdf):

[TN 017](#): Procedure for Replacing Lamp Housing in Model 202 and Model 205 Ozone Monitors™

[TN 018](#): Cleaning Procedure for Model 202 Ozone Monitor

The above are clickable links from the pdf version of the manual. If you are reading this from a hard copy, the links are: www.twobtech.com/TNxxx.pdf.

Also, please note that all 2B Tech instrument manuals are posted online at:

<http://www.twobtech.com/downloads.htm>

For your convenience, a Service Log, which may be printed, is provided in Section 11 of this manual for recording calibrations, replacement of pumps, lamps, etc. Records of repairs made at 2B Tech are maintained in a database at 2B Technologies as well. That database also includes detailed information about the construction and initial calibration of your instrument, including digital photos of its interior.

6. CALIBRATION

6.1. Introduction

Every analytical instrument is subject to some drift and variation in response, making it necessary to periodically check the calibration. Dynamic calibration is a multipoint check where gas samples of known concentration are sampled by the instrument in order to determine a calibration relationship. For more information on calibration of ozone monitors refer to the Code of Federal Regulations ([Title 40, Part 50, Appendix D](#)) and the EPA's [Technical Assistance Document for the Calibration of Ambient Ozone Monitors](#).

Calibration is the process of adjusting the gain and offset of the Model 202 Ozone Monitor against some recognized standard. The reliability of the data collected from any analytical instrument depends on the accuracy of the calibration, which is largely dependent upon its analytical traceability to a reference material or reference instrument calibration.

6.2. Ozone Standards

Because of the instability of ozone, the certification of ozone concentrations in a compressed gas cylinder is impossible due to loss of ozone over time. When ozone concentration standards are required, the ozone must be generated and certified on site. Ozone standards can be classified into two basic types:

1. A **Primary Ozone Standard** is the combination of an ozone generator and an ozone monitor based on UV absorbance (a UV photometer) that has been setup in accordance with the procedures prescribed by the U.S. Environmental Protection Agency (EPA) under [Title 40 of the Code of Federal Regulations, Part 50, Appendix D](#) (40 CFR Part 50).
2. An **Ozone Transfer Standard** is a system (a portable ozone monitor and/or a portable ozone generator), which can produce accurate ozone concentration standards which are quantitatively related to a primary ozone standard. An example of an ozone transfer standard is the 2B Technologies Model 306 Ozone Calibration Source. Ozone transfer standards must be certified before use in accordance with the procedures prescribed by the U.S. Environmental Protection Agency (EPA) under [Title 40 of the Code of Federal Regulations, Part 50, Appendix D](#) (40 CFR Part 50).

6.3. Equipment Required

The equipment that is needed to carry out the calibration is commercially available, or it can be assembled by the user. Calibration using a primary ozone standard involves the generation of ozone concentrations that are simultaneously measured by a

primary ozone standard and the instrument undergoing calibration. This procedure requires the following equipment:

1. Zero air source
2. Ozone generator
3. Sampling manifold (inert material such as PTFE or FEP only)
4. Sampling lines (inert materials such as PTFE or FEP only)
5. UV Photometer

Use of a certified transfer standard for calibration involves the generation of ozone concentrations, using the calibrated ozone generator, that are measured by the instrument undergoing calibration. This procedure requires the following equipment:

1. Zero air source
2. Certified Transfer Standard
3. Sampling manifold (inert material such as PTFE or FEP only)
4. Sampling lines (inert material such as PTFE or FEP only)

Zero air can be generated either from compressed cylinders or from scrubbed ambient air. If ambient air is used, contaminants such as ozone and nitric oxide must be removed. Detailed procedures for generating zero air are in the EPA's [Technical Assistance Document for the Calibration of Ambient Ozone Monitors](#).

6.4. Instrument Preparation

Prior to calibration, follow the steps below:

1. Turn on the Model 202 Ozone Monitor and allow it to stabilize for a minimum of one hour.
2. Connect the instrument to the manifold on the ozone calibration setup. If a particle filter will be used in normal operation, the calibration must be performed through the filter. The manifold must be vented to atmosphere so that pressure does not build up in the calibration setup. Connection of the Model 202 directly to a pressurized output of any device can damage the ozone monitor.
3. Verify that the flow rate into the manifold is greater than the total flow required by the ozone monitor and any other flow demand drawing from the manifold.

6.5. Calibration Setup Preparation

As indicated in the EPA Technical Assistance Document, there are several tests that should be performed prior to calibration to ensure the accuracy of the measurements. These tests include:

- Setup check
- Ozone loss test
- Linearity check
- Intercomparison test

6.5.1. Setup Check

A visual inspection of the calibration setup should be performed before calibration to verify that the setup is in proper order. All plumbing connections should be checked and verified to follow the manufacturer's instructions. Any obvious leaks should be fixed and the manifold and sampling lines should be checked for general cleanliness. For more information, refer to the manufacturer's User Manual for the primary ozone standard or ozone transfer standard.

6.5.2. Ozone Loss Test

Some ozone may be lost in the calibration setup due to reaction with the walls of the manifold and sampling lines. Any significant loss of ozone must be measured and be subsequently applied to correct the calibration measurements. For more information, refer to the manufacturer's User Manual for the primary ozone standard or ozone transfer standard.

6.5.3. Linearity Check

Since the Model 202 is inherently linear over several orders of magnitude, a linearity check provides a test that the instrument is operating properly. Instrument linearity can be checked by comparison to an ozone standard (see Calibration Procedure – Calibration Curve) or by dilution of an ozone measurement. To check the instrument linearity by dilution of an ozone measurement, generate and measure a concentration of ozone near the upper range of ozone monitor (80% of full scale is recommended). Additional ozone concentrations should be generated by accurately diluting the ozone flow with zero air and each concentration should be measured once the instrument reaches a stable response. The accuracy of the linearity test relies on the accuracy of the flow meters used to perform the dilution. The percent of non-linearity is calculated from the formula:

$$R = \frac{F_o}{F_o + F_d} \quad (2)$$

$$E = \frac{C_1 + \frac{C_2}{R}}{C_1} \times 100\% \quad (3)$$

where:

R = Dilution ratio

F_o = Ozone generator flow

F_d = Diluent zero air flow

E = Linearity error, in percent

C₁ = Measured concentration of original concentration

C₂ = Measured concentration of diluted concentration

The linearity error should not be greater than 5%. If the error is greater than 5%, the accuracy of the flow dilution should be checked before assuming that the ozone monitor is not linear. Note that the inherent linearity of the Model 202 is better than the error calculated in this linearity check due to the uncertainty introduced by the flow measurements.

6.5.4. Intercomparison Test

Comparison of the calibration setup with other ozone standards is a good check of the overall accuracy of the setup. If measurements from another ozone standard are found to deviate from the calibration setup greater than the instrument specifications, one of the calibration setups is not accurate.

6.6. Calibration Procedure

A multipoint calibration should be performed at least every 12 months or within the calibration frequency, any time major disassembly of components is performed, or any time the zero or span checks give results outside of the acceptable limits.

6.6.1. Instrument Preparation

1. Turn on the Model 202 Ozone Monitor and allow it to stabilize for a minimum of one hour.
2. Enter the calibration menu (**Main Menu / Cfg / Cal / O3**) and set the zero (Z) value to 0 and the slope (S) value to 1.00.
3. Connect the ozone monitor to the manifold on the ozone calibration setup. If a particle filter will be used in normal operation, the calibration must be performed through the filter. The manifold must be vented to atmosphere so that pressure does not build up in the calibration setup. Connection of the Model 202 directly to a pressurized output of any device can damage the ozone monitor.
4. Verify that the flow rate into the manifold is greater than the total flow required by the ozone monitor plus any other flow demand drawing from the manifold such as a UV photometer or ozone transfer standard.

6.6.2. Measurement of Zero Air

1. Verify that the zero air supply is on and the ozone generator is off. The same zero air supply used in the ozone generator must be used in the ozone generator.
2. Allow the Model 202 to sample zero air until the response is stable.
3. Record the average zero air response.

6.6.3. Measurement of Ozone Standards

1. Generate an ozone concentration slightly less than the concentration range of interest and allow the ozone generator to warm up for at least 5 minutes. The same zero air supply used for making zero air measurements must be used in the ozone generator.
2. Allow the Model 202 Ozone Monitor to sample the ozone concentration standard until a stable response is measured.
3. Record the average response of the ozone monitor as well as either the average response of the UV photometer or the transfer standard.
4. Generate several other ozone concentration standards. At least 5 ozone concentration standards are recommended over the range of interest.

5. For each ozone concentration standard, record the response of the ozone monitor as well as either the response of the UV photometer or the transfer standard.

6.6.4. Calibration Curve

1. Plot the Model 202 Monitor responses (y-axis) versus the corresponding standard ozone concentrations (x-axis).
2. Fit the data to a straight line ($y = mx + b$) using the linear regression technique to determine the calibration relationships, where m = slope and b = intercept.
3. Determine if any points deviate significantly from the line, which is an indication of an error in determining the calibration curve. The error may be due to the calibration setup or the ozone monitor being calibrated. The most likely problems in the ozone monitor are leaks, a malfunctioning ozone scrubber, a contaminated valve, or contamination in the optical setup. See the "Troubleshooting" section of the manual (Section 8).
4. The inverse of the slope of the line ($1/m$) is the gain factor (S) and the negative of the intercept ($-b$) is the offset (Z) that need to be applied to the ozone monitor response to calibrate it to the primary ozone standard. If the intercept is outside of the range from -10 to 10 or the slope is outside of the range from 0.90 to 1.10, this is an indication of a problem in the calibration setup or the ozone monitor being calibrated. The most likely problems in the ozone monitor are leaks, a malfunctioning ozone scrubber, a contaminated valve, or contamination in the optical setup. See the "Troubleshooting" section of this manual.
5. Enter the calibration menu (**Main Menu / Cfg / Cal / O3**) in the instrument software and set the calibration parameters Z and S as determined above (see Section 3.14 of this manual).

Refer also to our Technical Note No. 015 on calibration of 2B Tech Ozone Monitors, posted on our website: http://twobtech.com/docs/tech_notes/TN015.pdf.

7. PERIODIC ZERO AND SPAN CHECKS

To ensure the quality of the ozone monitor data, periodic zero and span checks can be performed by following the steps below:

1. A zero check is performed by sampling zero air with the Model 202 following the “Measurement of Zero Air” Section 6.6.2 above.
2. A span check is performed by sampling an ozone concentration at the high end of the concentration range of interest following the “Measurement of Ozone Standards” Section 6.6.3 above.
3. Average measurements from the zero check or span check should be within the instrument specifications. If the measurements are not within specifications, this is an indication of problem in the calibration setup or the ozone monitor being checked. The most likely problems in the ozone monitor are leaks, a malfunctioning ozone scrubber, a contaminated valve, or contamination in the optical setup. See the “Troubleshooting” section of the manual (Section 8).

8. TROUBLESHOOTING

If the instrument fails to operate correctly, common problems can be identified and corrected using Table 8-1. If the problem cannot be easily corrected, please contact Customer Service at 2B Tech via our web ticketing software at:

www.twobtech.com/techsupport

Alternatively, you can email us at techsupport@twobtech.com or call us at +1(303)273-0559. If we mutually determine that the instrument cannot be repaired onsite, we will provide you with a Return Authorization number and a short form to be filled out and returned to our Service Department along with the instrument.

Following Table 8-1, the figures in Section 9 provide a “guided tour” of the Model 202 Ozone Monitor™ so that critical components and connectors may be easily identified. A list of serviceable parts is provided in Section 10 of this manual.

Table 8-1. Troubleshooting the Ozone Monitor for performance problems.

Problem/symptom	Likely cause	Corrective action
<i>Instrument does not turn on.</i>	<p>Power not connected properly or circuit breaker open.</p> <p>Power cable not connected to circuit board.</p>	<p>Check external power connection for reverse polarity or a short and wait a few minutes for the thermal circuit breaker to reset.</p> <p>Remove top cover and disconnect and reconnect power cable to circuit board (see Figure 9-3).</p>
<i>Instrument turns on then powers off.</i>	Burned out air pump.	Remove top cover and unplug air pump (see Figure 9-3). Turn instrument on; if instrument remains running, then the air pump motor is burned out and shorting. Replace air pump.
<i>Display is blank or nonsense.</i>	Bad connection of display to circuit board.	Remove top cover and reconnect display to circuit board (see Figure 9-3). Check solder connections to display.

<i>Cell temperature reads low by several 10's of degrees.</i>	Absent or loose connection of temperature probe cable to circuit board.	Remove top cover and reattach connector to circuit board (see Figure 9-3).
<i>Readings are noisy with standard deviations greater than 2.0 ppbv.</i>	Lamp output is weak. Excessive vibration. Flow path contaminated.	Remove top cover and check lamp connection to circuit board (see Figure 9-3). Run Lamp Test from menu. If photodiode voltage is less than 0.7 V, replace lamp. Provide additional vibration insulation for the instrument such as a foam pad. Clean flow path with methanol according to the Cleaning Procedure (see Tech Note 018).
<i>Analog output is constant or does not track front display.</i>	Cable not properly connected between analog output BNC and circuit board. Wrong scaling factor selected in Menu.	Remove top cover and reconnect cable between analog output and circuit board (see Figure 9-3). Check and reset analog output scaling factor in the Menu.
<i>Select switch does not work.</i>	Cable not properly connected between select switch and circuit board.	Remove top cover and reconnect select switch cable to circuit board (see Figure 9-3).
<i>Serial port does not work.</i>	Cable not properly connected between serial port 9-pin connector and circuit board. Wrong serial cable used.	Remove top cover and reconnect serial port cable to circuit board (see Figure 9-3). A "straight through" serial cable is provided. Some data collection devices require a "cross over" cable in which pins 1 and 3 are exchanged between the two ends of the cable. Use a "cross over cable or additional connector that switches pins 1 and 3.

	Wrong baud rate selected.	Make sure that the baud rate chosen in the menu matches the baud rate setting of your data acquisition program.
<i>Required calibration parameters are outside the adjustable range (± 9 ppbv offset and/or $\pm 9\%$ slope) when calibrated using a standard ozone source or reliable ozone instrument.</i>	<p>Ozone scrubber is contaminated.</p> <p>Flow path is contaminated.</p> <p>Solenoid valve is contaminated and not opening and closing properly.</p> <p>Air pump is not drawing sufficient flow.</p>	<p>Replace ozone scrubber. Be sure to use an inlet filter to remove particulate matter.</p> <p>Clean flow path with methanol following the Cleaning Procedure (Tech Note 018).</p> <p>Remove solenoid valve, rinse with methanol, dry with zero air, and replace.</p> <p>As a first check, hold your finger over the air inlet to determine whether air is being drawn in. If there is flow, measure the flow rate by removing the bottom cover and attaching a high conductance flow meter to the exit port of the pump. Air flow should be greater than 0.7 L/min. If flow is lower, check for leaks. If there are no leaks, replace air pump.</p>
<i>Instrument always reads close to zero for ozone concentration.</i>	Solenoid valve cable is not properly connected to circuit board.	Reattach solenoid valve cable to circuit board (see Figure 9-3).

9. LABELED INSTRUMENT PHOTOS

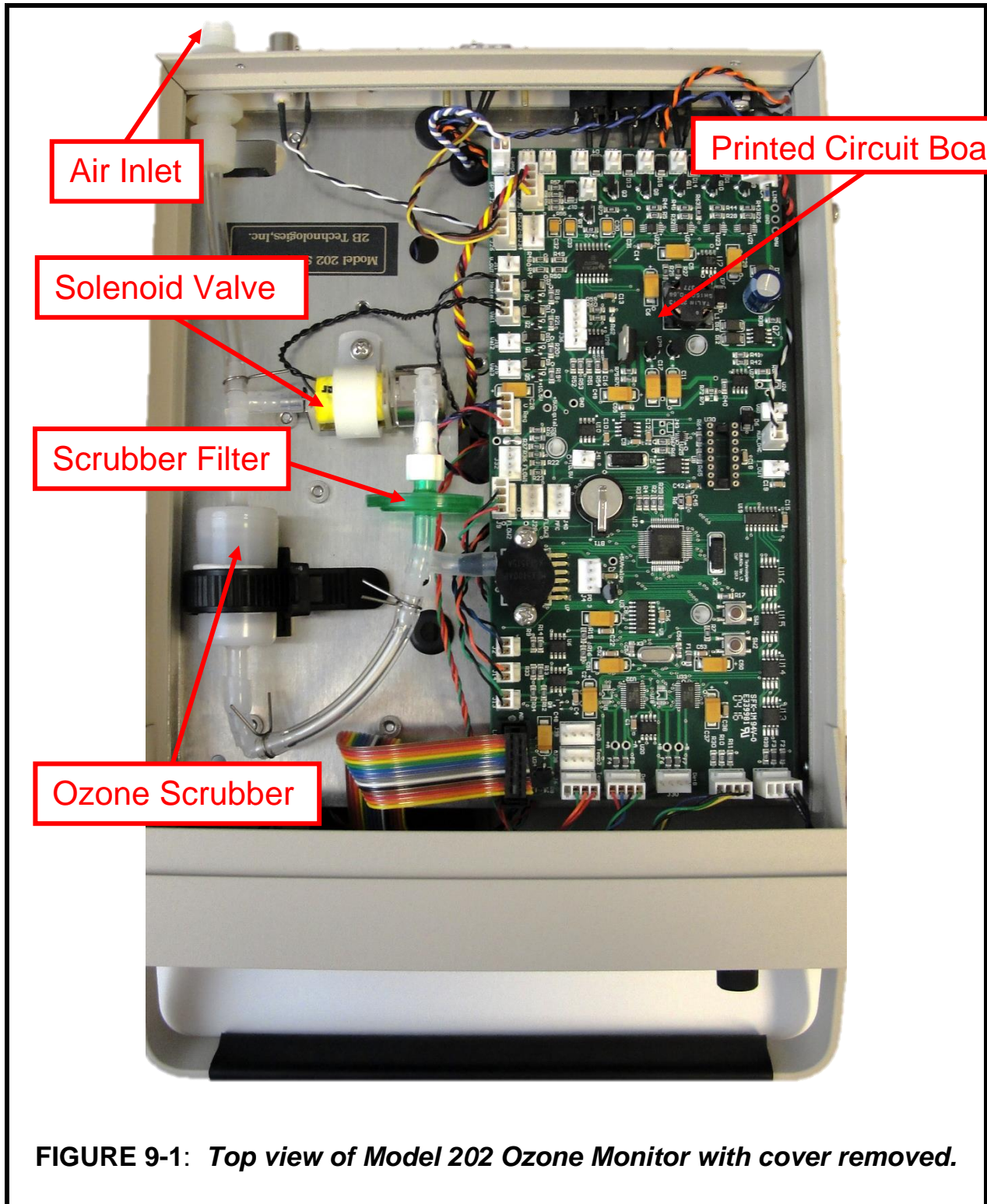

FIGURE 9-1: Top view of Model 202 Ozone Monitor with cover removed.

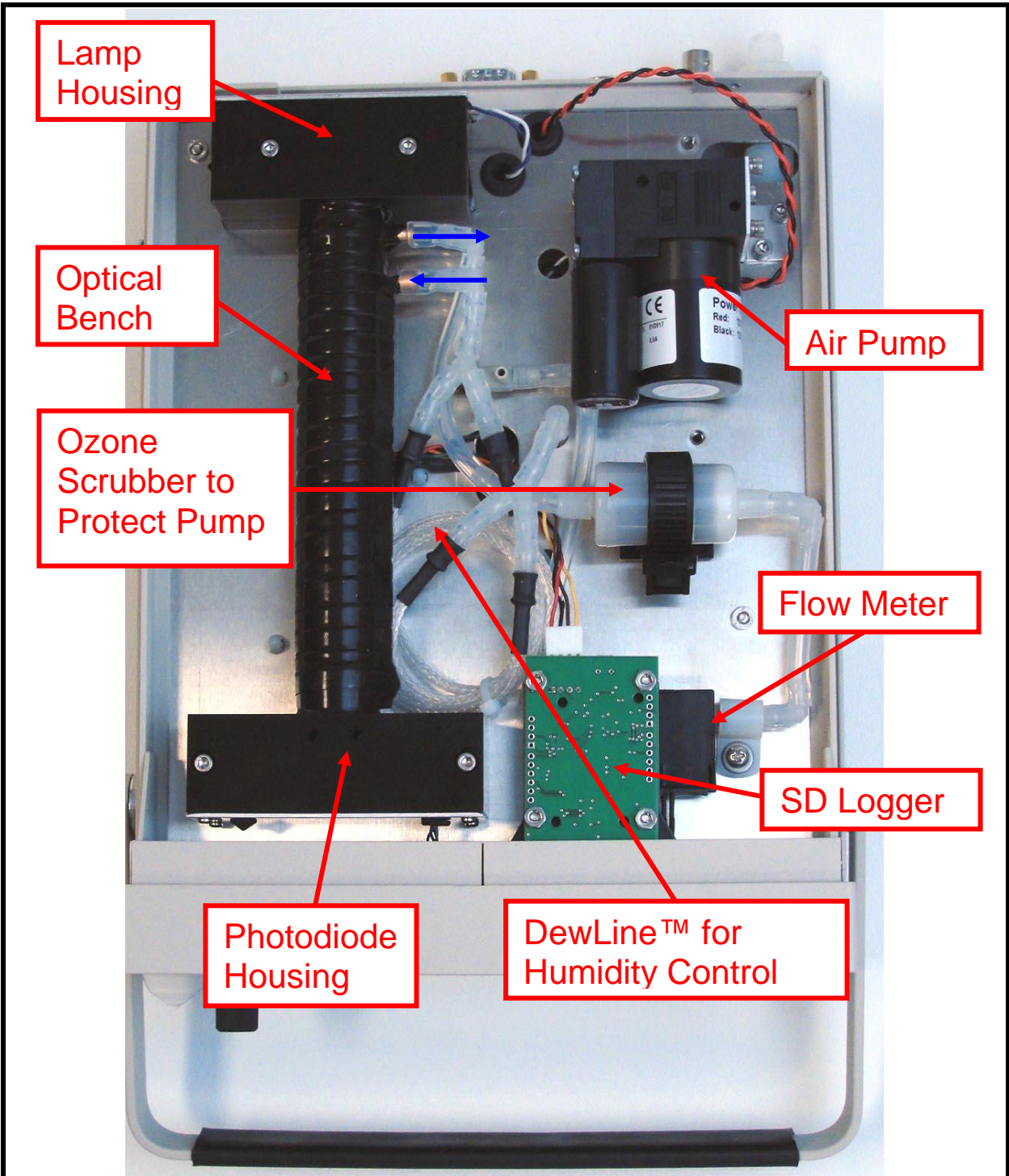

FIGURE 9-2a: Bottom view of Model 202 Ozone Monitor with cover removed, standard version (SN 1900 and above).

This view shows the quiet pump and SD data logger, which are standard on Model 202 instruments with serial number 1900 and above.

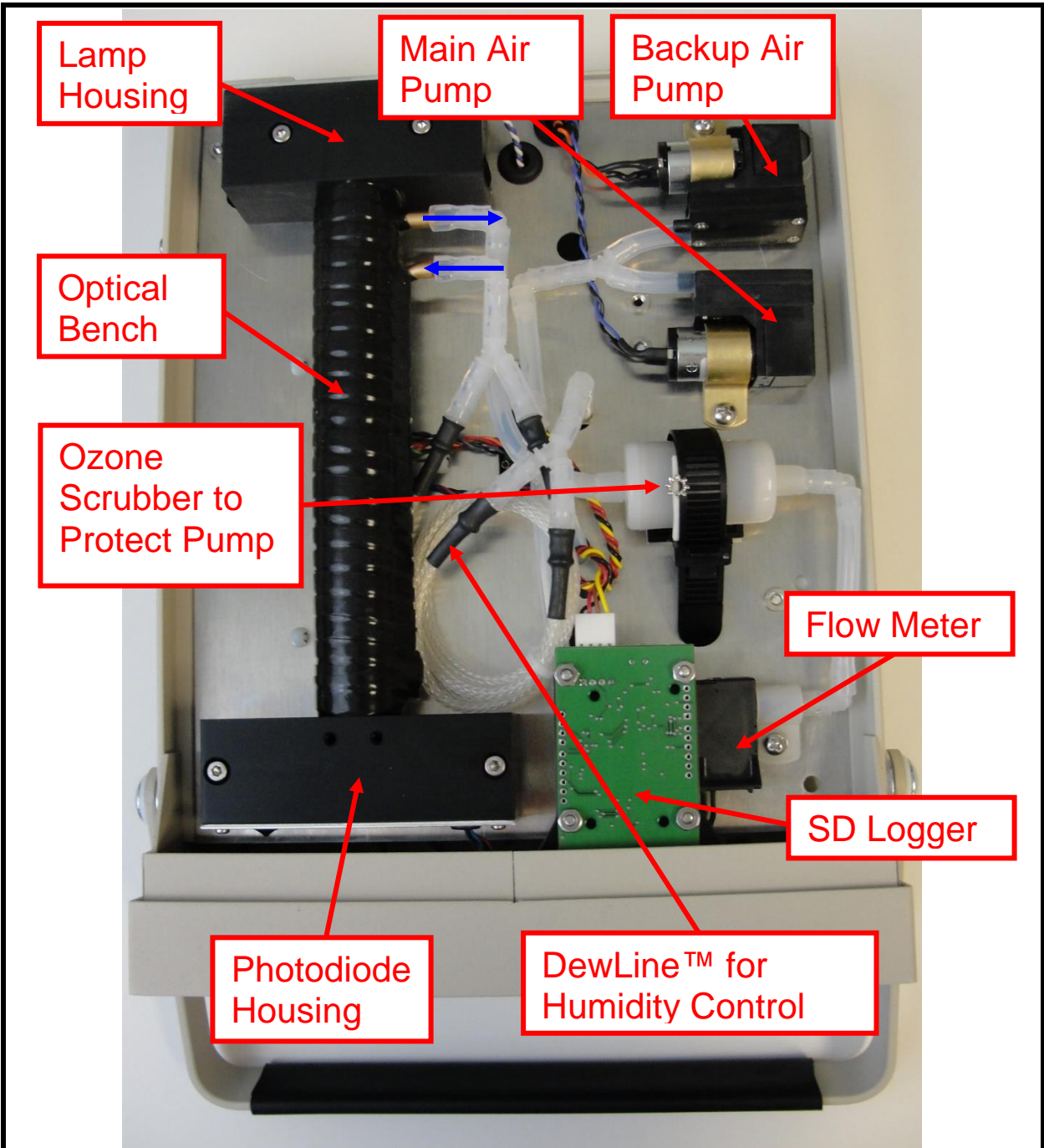

FIGURE 9-2b: Bottom view of Model 202 Ozone Monitor with cover removed (SN 1899 and below).

Earlier versions of the Model 202 Ozone Monitor came with the pump configuration (main and backup) shown here. This pump consumes 1 to 2 watts less power than the pump shown in Figure 9-2a, but is louder and has a lower lifetime (~5000 hours each). If power is the main concern, a Model 202 Ozone Monitor may be purchased with a Low-Power Option that uses the pump configuration shown in this figure.

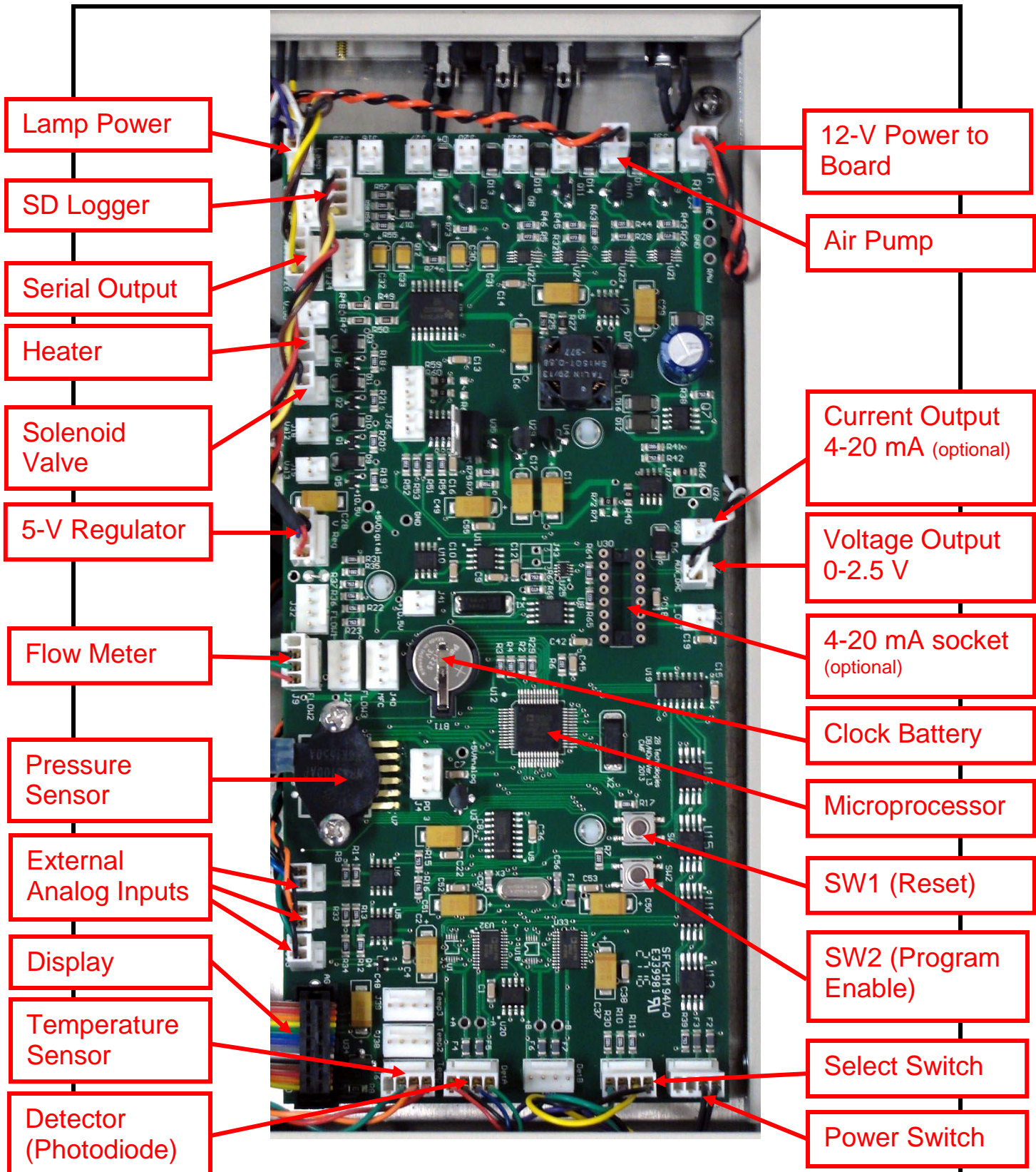

FIGURE 9-3: Printed Circuit Board.

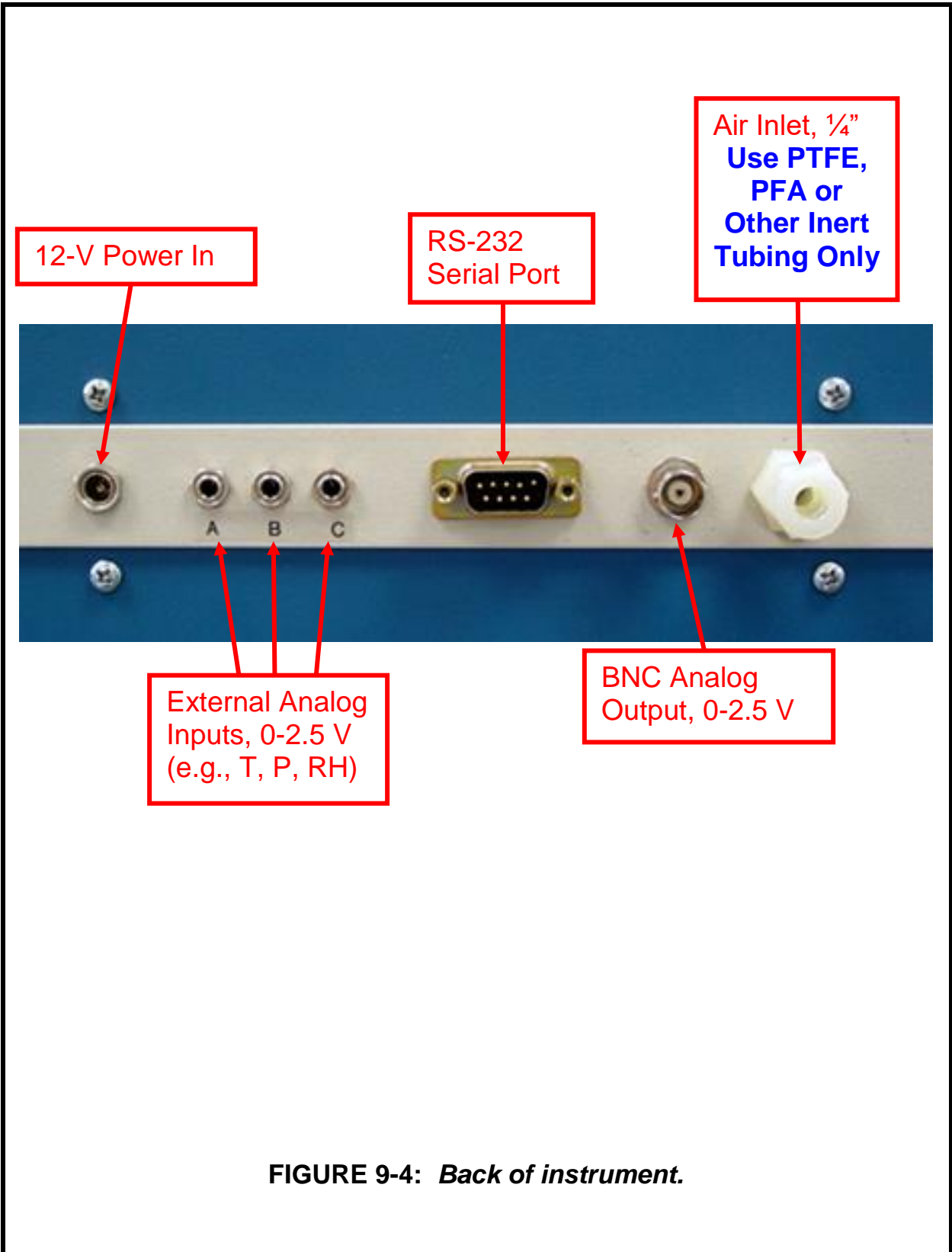

FIGURE 9-4: Back of instrument.

10. PARTS LIST

The following list includes those parts of the Model 202 Ozone Monitor that are user serviceable.

Please see the 2B Technologies website for a full and updated list of parts and pricing: <http://twobtech.com/parts-online.html>

<u>Part Number</u>	<u>Description</u>
SCRBINT	Ozone scrubber (internal)
SCRBEXT	Ozone scrubber (external)
OZLAMPAS202	Lamp and connector assembly
OZVLV202	Solenoid valve and cable
OZDSP	LCD display and cable
PDASSEMBLY	Photodiode assembly
OZPUMP202OLD	Internal air pump for Model 202 Ozone Monitor (for instruments with serial no. 1899 and earlier; also for newer instruments purchased with Low Power Option)
OZPUMP202QUIET	Internal air pump for Model 202 (serial no. 1900 and above)
OZCELL	Absorption cell
FLOWMETER	Flow meter assembly
DEW	DewLine™ (two Nafion tubes in parallel)
SELECTSWITCH	Select switch assembly, including external knob
SERCABL	Serial port cable (to computer)
SDCARD	SD card (thin profile recommended for the Model 205 and Model 202 Ozone Monitors)
SDREADER	SD card reader
PWRPK-1.25A	Power pack, 1.25 amp output at 12 V
CIGADAP	12 V DC cigarette lighter adapter
ANINJACKS	Analog input jacks, set of 3
TEFTYG25	Teflon-lined Tygon® tubing (25 ft)
TEFTYG05	Teflon-lined Tygon® tubing (5 ft)
SILTUB05	Silicone tubing (5 ft)
FILTERHS(47mm)	Particle Filter Housing, 47 mm with ¼" Fittings
FILTERPK(47mm)	Package of Ten 47-mm PTFE Particle Filters, 5-6 µm pore size
CLEANLOOP	Cleaning loop set

[Note: Some parts differ for instruments with serial numbers below 300. Please see website.]

Appendix A: Using the 2B Technologies Display and Graphing Software

Copyright© 2B Technologies, Inc. All rights reserved

Introduction

2B Data Display® is an easy way to display and save data from your serial or USB connection.

With easy one-click operations, data are read from your instrument and displayed on an extremely versatile chart. Two items, such as Ozone and Temperature, can be displayed simultaneously on the chart with multiple zoom levels. Data are automatically saved to a .txt file and can optionally be saved to a .CSV file to be read in Excel. Saved data can be restored for later viewing and analyzing on the chart. By requesting an account with 2B Technologies, you can upload your data and view it on a Google Earth overlay.

Downloading the Software

Go to http://twobtech.com/downloads_software.html and select the Software tab. Click the link for “2B Tech Display and Download Software.” Follow the instructions, doing the two installations if needed and choosing to save the “setup.exe” file. Double-click the setup.exe download to launch the 2B Data Display application.

Connecting Devices

Connect to a Monitor

1. Select the device you are connecting to from Settings: Select Device...
2. Click OK.
3. Select the Connection you will be using from Settings: Connection...
Choose the settings as follows:
 - a) Port:
 - The default port is “COM1” for computers with a serial port.
 - If using a USB connection, check for the correct port in the “Device Manager” under “Ports” located in: Control Panel : System : Device Manager.
 - If using a USB to Serial adapter, check for the correct port the same as for a USB connection and look for the name of the adapter (e.g., Belkin, Prolific, or other USB to Serial adapter manufacturers).
 - b) Baud Rate: The Default baud rate of the software is 2400. Check your monitor’s settings in the “Cfg / I/O” menu and match the software with the monitor’s setting (19200 for the POM). Note that for the USB port, the baud rate must match the baud rate of the Monitor at the Monitor’s startup.
 - c) Parity: None
 - d) Data Bits: 8
 - e) Stop Bits: One

4. Click Start button in the Instrument Data Capture section in the upper left corner of the main screen.
 - a) The “Save As” window will appear. A default file name will appear which is made of the date and time. You may change the filename and change where it is saved if you wish.
 - b) Click the “Save” button. This will start the data capture software and data will fill into the chart as they are transmitted from the device.
 - c) The red OFF text will change to green ON text. The text: Waiting for data... will appear until data arrives from the instrument. If the instrument measurement frequency is set to 2 seconds (fast mode), you will see a data point every 2 seconds. The instrument can be set to 10 seconds (measurement mode) or to averaging modes of 1 minute, 5 minutes, and 1 hour in the Avg submenu on the instrument.

Connect to Weather Station (Davis Vantage Pro)

1. Be sure the weather station is physically connected to the USB port or Serial port of the computer.
2. Select the COM port for the weather station from *Settings : Weather Connection Settings...*
3. Select “Retrieve Weather Data” from the “Weather Link” menu. A window will appear and the software will try to retrieve the weather station data. If the connection is good, weather data will be displayed in the window. If not, an error message will appear. Try a different com port if the error message appears. You may move this window so it is out of the way or you may close it. The weather data is updated every 5 seconds.
 - Since the Monitor and the Weather Station both use COM ports, you may have to unplug one of the USB adapters from the PC to determine which device is using which COM port.
4. To bring up the window again if you have closed it, select “Display Weather Data.”

Viewing Data

The Data Grid Tab

1. Make sure the application is connected to a device or that you have opened a previously saved data file.
2. Click the *Data Grid* tab on the right side of the screen.
3. The data lines received from your instrument will be listed in a grid with the latest point at the top.
4. The header contains the device specific variables (e.g., Ozone, Cell Temp...). Log Number is always listed even if your instrument is not set to log.

The Charts Tab

1. Make sure the application is connected to a device or you have opened a previously saved data file.
2. Click the *Charts* tab on the right side of the screen.
3. Select which data items to display from the drop down windows “Data 1” and “Data 2.”

4. The data points will appear in a graph window in the middle of the screen.
5. Adjust the zoom level by pressing the + or – buttons under the *Settings* button (upper right side of screen).
6. Adjust the Y scale or set the *Auto Range* feature by pressing the *Settings* button
 - a. Check the *Auto Range* box to use autoscaling.
 - b. Uncheck the *Auto Range* box to manually set Y max and Y min for the Data 1 and Data 2 fields.

The Buffer Tab

- Selecting the Buffer tab brings up a buffer window, similar to Tera Term or HyperTerminal, where all data from the serial port are displayed.
- From this tab, the user can also send commands through the serial port by typing on the keyboard. This is only applicable if the device that is connected accepts serial commands. See the instrument manual for a list of the serial commands.
- This buffer window can also be used for troubleshooting for instances when: the baud rate, device, or serial port is unknown. For example, if the status bar in the “Instrument Data Capture area states “Receiving...” and no data appear in the Data Grid or the Charts, click on the Buffer tab to view the serial data. If the correct device is not selected, no data will be displayed in the Data Grid or the Charts, but data will be displayed in the Buffer window.

Saving Data

Saving Data to a .txt File

1. Click the *Start* button in the Instrument Data Section to begin collecting data from the instrument.
2. A window will pop up to prompt for the name and location of the file.
3. Click Save to begin the data collection.
4. All data read from the monitor through the COM port are written to the .txt file in real time until *Stop* is clicked.

Saving Data to a .CSV or an Excel File

NOTE: Weather data are NOT saved to the .txt file. In order to save weather data, be sure to save a .CSV file after *Stop* is clicked.

1. After collecting data, click the *Stop* button in the Instrument Data Capture Section on the main screen.
2. A window will pop up to ask you if you would like to save to a CSV file as well. Click *Yes*.
3. A default name appears from the date and time of the data capture. You may change the name and path of the file if you wish.
4. Click on the *Save* button.

Opening Files

1. To open a file, click *Open* from the *File* menu.
2. Navigate to the folder where the file was stored.
3. Select either the .txt file or the excel file and press *Open*.

1. NOTE: To view weather data, you must open the corresponding .CSV file.
4. Choose the correct device associated with the file.
 - a. If you are unsure, open the file in a text editor or Excel to determine which device.

Serial and USB Commands

The menu commands are the same as given in Section 4 of this manual.