

**AirSep<sup>®</sup> Corporation**  
**Centrox**  
**PSA Oxygen Concentrator**

***Instruction Manual***

MN124-1    03/11    Rev. B





# Ownership Data

Take a moment to note important information below about your AirSep CENTROX PSA Oxygen Concentrator. Keep this instruction manual, along with your invoice, to serve as a permanent record of your purchase.

## ***PSA Oxygen Concentrator***

Model Number:

Serial Number:

Invoice Date:

Start-Up Date:

## ***AirSep Representative***

Company:

Contact:

Address:

City/Town:  State:  Zip:

Country:  Fax:

Telephone:  Telex:



Before you attempt to install, operate, or repair the oxygen concentrator, read and thoroughly understand this instruction manual. Improper operation can result in severe bodily injury, damage to the system, or poor performance.



## **Table of Contents**

|                   |  |                   |
|-------------------|--|-------------------|
| <b><u>1.0</u></b> | <b><u>Introduction</u></b> .....                               | <b><u>1-1</u></b> |
| 1.1               | <u>General</u> .....   | <u>1-1</u>        |
| 1.2               | <u>Warnings, Cautions, and Notes</u> .....                     | <u>1-1</u>        |
| 1.3               | <u>References to Controls and Indicators with Labels</u> ..... | <u>1-1</u>        |
| <b><u>2.0</u></b> | <b><u>Safety</u></b> .....                                     | <b><u>2-1</u></b> |
| 2.1               | <u>General</u> .....   | <u>2-1</u>        |
| 2.2               | <u>Potential Hazards</u> .....                                 | <u>2-1</u>        |
| 2.3               | <u>Safety Publications</u> .....                               | <u>2-3</u>        |
| <b><u>3.0</u></b> | <b><u>System Description</u></b> .....                         | <b><u>3-1</u></b> |
| 3.1               | <u>Introduction</u> .....                                      | <u>3-1</u>        |
| <b><u>4.0</u></b> | <b><u>Controls, Parts, and Connections</u></b> .....           | <b><u>4-1</u></b> |
| 4.1               | <u>Introduction</u> .....                                      | <u>4-1</u>        |
| 4.2               | <u>Oxygen Concentrator Controls and Indicators</u> .....       | <u>4-1</u>        |
| 4.3               | <u>Oxygen Concentrator Parts</u> .....                         | <u>4-4</u>        |
| 4.4               | <u>Auxiliary Kits Information (Optional)</u> .....             | <u>4-8</u>        |
| 4.5               | <u>Connections</u> .....                                       | <u>4-10</u>       |
| <b><u>5.0</u></b> | <b><u>Installation</u></b> .....                               | <b><u>5-1</u></b> |
| 5.1               | <u>Unpacking</u> .....   | <u>5-1</u>        |
| 5.2               | <u>Pre-Installation Guidelines</u> .....                       | <u>5-3</u>        |
| 5.3               | <u>Installation Instructions</u> .....                         | <u>5-4</u>        |
| <b><u>6.0</u></b> | <b><u>Operation</u></b> .....                                  | <b><u>6-1</u></b> |
| 6.1               | <u>Initial Start-Up</u> .....                                  | <u>6-1</u>        |
| 6.2               | <u>Operation</u> .....   | <u>6-4</u>        |
| 6.3               | <u>Shutdown</u> .....  | <u>6-5</u>        |
| 6.4               | <u>Normal Start-Up</u> .....                                   | <u>6-5</u>        |
| 6.5               | <u>Start-Up after an Extended Shutdown</u> .....               | <u>6-5</u>        |

|                   |   |                   |
|-------------------|---|-------------------|
| <b><u>7.0</u></b> | <b><u>Maintenance/Service</u></b> .....           | <b><u>7-1</u></b> |
| 7.1               | <u>Weekly Maintenance</u> .....                   | <u>7-2</u>        |
| 7.2               | <u>Semi-Annual Maintenance</u> .....              | <u>7-2</u>        |
| 7.3               | <u>Annual Maintenance</u> .....                   | <u>7-4</u>        |
| 7.4               | <u>Pressure Switch Adjustment Procedure</u> ..... | <u>7-5</u>        |
| <b><u>8.0</u></b> | <b><u>Troubleshooting</u></b> .....               | <b><u>8-1</u></b> |
|                   | <u>Troubleshooting Chart</u> .....                | <u>8-2</u>        |
| <b><u>A</u></b>   | <b><u>Appendix Technical Data</u></b> .....       | <b><u>A-1</u></b> |
| <b><u>B</u></b>   | <b><u>Appendix Warranty&gt;Returns</u></b> .....  | <b><u>B-1</u></b> |
| <b><u>C</u></b>   | <b><u>Appendix Parts List</u></b> .....           | <b><u>C-1</u></b> |
| <b><u>D</u></b>   | <b><u>Appendix Component Literature</u></b> ..... | <b><u>D-1</u></b> |

## **List of Illustrations**

|  |                            |
|--|----------------------------|
| <a href="#"><u>Figure 3.1: CENTROX Oxygen Concentrator</u></a> .....                       | <a href="#"><u>3-1</u></a> |
| <a href="#"><u>Figure 4.1: Compressor Enclosure</u></a> .....                              | <a href="#"><u>4-1</u></a> |
| <a href="#"><u>Figure 4.2: PSA Enclosure Controls and Indicators</u></a> .....             | <a href="#"><u>4-2</u></a> |
| <a href="#"><u>Figure 4.3: Compressor Enclosure Internal Components</u></a> .....          | <a href="#"><u>4-4</u></a> |
| <a href="#"><u>Figure 4.4: PSA Enclosure Internal Components</u></a> .....                 | <a href="#"><u>4-5</u></a> |
| <a href="#"><u>Figure 4.5: Oxygen Receiver</u></a> .....                                   | <a href="#"><u>4-9</u></a> |
| <a href="#"><u>Figure 5.1: General Arrangement of the CENTROX concentrator</u></a> .....   | <a href="#"><u>5-5</u></a> |
| <a href="#"><u>Figure 6.1: PSA Enclosure Supply Valve Assembly</u></a> .....               | <a href="#"><u>6-4</u></a> |
| <a href="#"><u>Figure 7.1: Pressure Switch</u></a> .....                                   | <a href="#"><u>7-6</u></a> |
| <a href="#"><u>Figure A.1: Flow Schematic</u></a> .....                                    | <a href="#"><u>A-5</u></a> |
| <a href="#"><u>Figure A.2: Wiring Schematic (120 V, 60 Hz) – PSA Enclosure</u></a> .....   | <a href="#"><u>A-6</u></a> |
| <a href="#"><u>Figure A.3: Wiring Schematic (240 V, 50 Hz) – PSA Enclosure</u></a> .....   | <a href="#"><u>A-7</u></a> |
| <a href="#"><u>Figure A.4: Wiring Schematic (120 V, 60 Hz) Compressor Enclosure</u></a> .. | <a href="#"><u>A-8</u></a> |
| <a href="#"><u>Figure A.5: Wiring Schematic (240 V, 50 Hz) Compressor Enclosure</u></a> .. | <a href="#"><u>A-9</u></a> |





## **1.0 Introduction**

### **1.1 General**

This instruction manual provides a description of the AirSep CENTROX Pressure Swing Adsorption (PSA) Oxygen Concentrator as well as instructions for its installation, operation, and maintenance. Pertinent drawings and component information are also included.

To ensure safe operation and proper system maintenance, AirSep Corporation recommends that you keep this instruction manual readily available for reference.

### **1.2 Warnings, Cautions, and Notes**

As you read the instruction manual, pay special attention to the Warning, Caution, and Note messages. They identify safety guidelines or other important information as follows:



Provides information that can prevent severe bodily injury or death.



Provides information that can prevent minor bodily injury or property damage.



Provides information important enough to emphasize or repeat.

### **1.3 References to Controls and Indicators with Labels**

This operating manual uses uppercase characters (e.g., ON/OFF switch) to refer to controls and indicators. Refer to section 4 for a description of all the controls and indicators of the oxygen concentrator.



## 2.0 Safety

### 2.1 General

Oxygen, the most abundant of the elements, makes up about 50 percent of the earth's crust. In its free state, it forms about one-fifth of our air by volume. Although oxygen is classified as a non-flammable gas, it supports combustion. As an active element, it combines directly or indirectly with all elements except the rare gases. It is an invisible gas that is colorless, odorless, and tasteless.

To ensure your safety, thoroughly read and familiarize yourself with this Safety section. AirSep Corporation strongly recommends that you review this section periodically.

### 2.2 Potential Hazards

Before you attempt to install, operate, or repair the CENTROX Oxygen Concentrator, read and thoroughly understand this instruction manual. Improper operation can result in severe bodily injury, damage to the system, or poor performance.



It is recommended to have an alternate source of oxygen supply if a power failure or equipment malfunction occurs.



Take extreme care to keep all the oxygen piping and vessel clean. To avoid a fire or an explosion, oxygen clean all surfaces that can come in contact with oxygen. Check all oxygen fittings/joints for leaks with an oxygen-compatible leak-detecting solution.



Oxygen vigorously accelerates the burning of combustible materials. In an oxygen-enriched atmosphere, many materials that do not burn in normal air require only a slight spark or moderate heat to set them aflame.

To avoid a fire or an explosion, keep gasoline, kerosene, oil, grease, cotton fibers, paint, and any other combustible material away from any part of the CENTROX Oxygen Concentrator or optional auxiliary oxygen receiver.

Do not smoke or use an open flame near the oxygen concentrator or optional auxiliary oxygen receiver.

Post "NO SMOKING OR OPEN FLAMES" signs in the area where the oxygen concentrator and optional auxiliary oxygen receiver are located. AirSep **STRONGLY** recommends that only individuals trained and experienced in the safe handling of oxygen operate this system.



The interior of the CENTROX Oxygen Concentrator contains electrical parts that can produce an electrical hazard if not handled properly. To prevent electrical shock, read and thoroughly understand the Troubleshooting section of this instruction manual before you service the system.



Connect the oxygen concentrator power cord to a properly grounded wall outlet on a circuit that cannot be accidentally turned off. Do not use extension cords.



To prevent fire or electrical shock, locate the oxygen concentrator and the auxiliary oxygen receiver (if supplied) indoors away from rain or any other type of moisture.



Disconnect power before servicing oxygen generator.

## 2.3 Safety Publications

This section is not a complete summary of required safety procedures. Review the following publications for additional information on the safe handling of oxygen:

- "Installation of Bulk Oxygen Systems at Consumer Sites;" NFPA No. 50; National Fire Protection Association; 1 Batterymarch Park; P. O. Box 9101; Quincy, Massachusetts 02269-9101 USA.
- "Oxygen;" Pamphlet G-4; Compressed Gas Association; 1725 Jefferson Davis Highway; Arlington, Virginia 22202-4102 USA.
- "Cleaning Equipment For Oxygen Service," Pamphlet G-4.1; Compressed Gas Association; 1725 Jefferson Davis Highway; Arlington, Virginia 22202-4102 USA.



## 3.0 System Description

### 3.1 Introduction

Air Contains 21 % oxygen, 78% nitrogen, 0.9% argon, and 0.1% other gases. AirSep Oxygen Concentrator separates this small percentage of the oxygen from the compressed air through a unique Pressure Swing Adsorption (PSA) process.

The CENTROX unit consists of two enclosures. The smaller enclosure contains two compressors that supply air for the process. Each compressor has a dedicated switch and circuit breaker. The cord from the enclosure plugs into the PSA enclosure. This cord must not be plugged into any other power supply outlet. Circuitry inside the PSA enclosure controls the power supplied to the compressors. The power cord from the PSA enclosure plugs into the wall. Figure 3.1 shows the two enclosures of the CENTROX oxygen concentrator.



**Figure 3.1: CENTROX Oxygen Concentrator**

The compressor enclosure (See Figure 3.1) supplies pressurized air to the PSA enclosure (See Figure 3.1). Inside the PSA enclosure, the pressurized air enters the feed & waste manifold (See Figure 4.4). A series of valves in the feed & waste manifold controls the flow of air into each of the adsorber beds (See Figure 4.4). Valves also connect the beds to two mufflers (See Figure 4.4) that allow waste gas to be vented from the beds. The oxygen concentrator uses in its adsorber vessels an inert ceramic material called molecular sieve to separate compressed air into the oxygen and the other gases. The unique properties of molecular sieve allow it to attract, or adsorb, nitrogen physically from air under pressure.

This allows oxygen to exit the adsorbers as a product gas. Oxygen from top of the beds then flows to the check valve assembly and then to the product manifold (See Figure 4.4). The check valve assembly supplies product oxygen to the flow controller. The product manifold controls the flow of oxygen from one bed to another during various stages of the oxygen generating process. The product oxygen then flows through the product valve to the customer's application. An oxygen analyzer continuously monitors the purity of oxygen and provides an alarm in case of low purity.

The entire oxygen generating process is completely regenerative, which makes it both reliable and virtually maintenance-free. The molecular sieve does not normally require replacement.

This instruction manual serves as the guidelines for CENTROX oxygen concentrator. Refer to the illustrations, located in the Appendix A of this instruction manual, for the detailed flow diagram and electrical schematic of the oxygen concentrator referenced in this instruction manual.



## 4.0 Controls, Parts, and Connections

### 4.1 Introduction

The section describes the various parts, controls, indicators and connections required for the CENTROX oxygen concentrator.

### 4.2 Oxygen Concentrator Controls and Indicators

#### 4.2.1 Compressor Enclosure

Figure 4.1 shows the compressor enclosure along with all the controls and indicators.

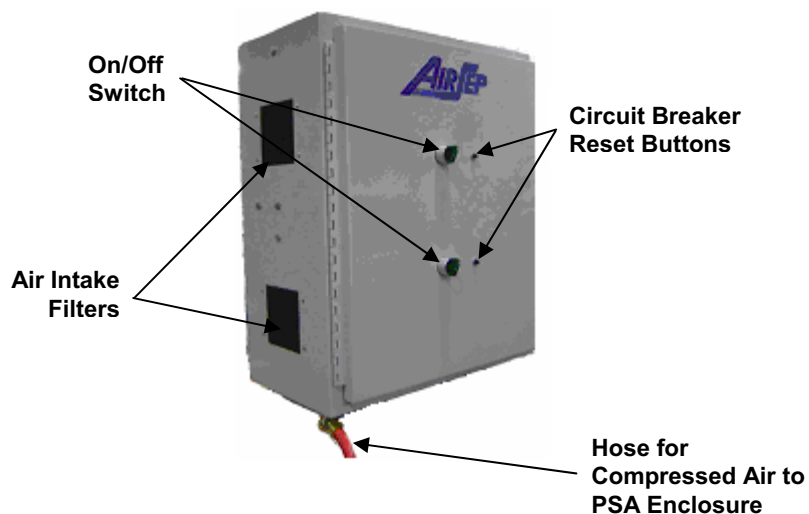

*Figure 4.1: Compressor Enclosure*

#### **ON/OFF (Power) Switch**

The individual ON/OFF switches (green color) on the compressor enclosure starts and stops the operation of the oxygen compressors. When you supply power to the system, the green indicator light of the switches turns on. It remains lit whether the switch is in the ON or OFF position (See Figure 4.1).

#### **Circuit Breaker Reset Buttons**

The individual circuit breaker reset buttons on the compressor enclosure are used to reset the compressors after an electrical overload shutdown (See Figure 4.1).

### Air Intake Filters

Located on the left side panel, the air intake filter removes any foreign particles from the air that enters the compressor enclosure (See Figure 4.1).



Fuses/Circuit Breakers, if required, must be replaced with the same type and amp rating as the original.

## 4.2.2 PSA Enclosure

Figure 4.2 shows the controls and indicators of the PSA enclosure.



*Figure 4.2: PSA Enclosure Controls and Indicators*

### ON/OFF (Power) Switch

The ON/OFF switch starts and stops the operation of the oxygen concentrator. When you supply power to the system, the switch's green indicator light turns on. It remains lit whether the switch is in the ON or OFF position (See Figure 4.2).

### AUTO/MANUAL Switch

The AUTO/MANUAL switch includes an yellow indicator light. In the AUTO position, the concentrator cycles on and off to meet oxygen demand. In the MANUAL position, the concentrator cycles continuously. The concentrator produces oxygen only while the yellow light is lit (See Figure 4.2).

### Hour Meter

The hour meter indicates the total number of hours the concentrator has cycled (See Figure 4.2).

### **Low Purity Light**

The unit is equipped with an oxygen sensor. If the purity supplied to the tank is below 85 % ( $\pm 3\%$ ), the red light on the PSA enclosure will be on (See Figure 4.2).

### **Low Purity Alarm**

If the purity is below 85 % ( $\pm 3\%$ ) for more than 30 minutes, an audible alarm will sound (See Figure 4.2).



The low oxygen purity alarm will sound for 4 seconds when the unit is turned on.

### **FEED AIR PRESSURE Gauge**

The FEED AIR PRESSURE gauge indicates the pressure of the feed air before it enters the PSA enclosure (See Figure 4.2).

### **PRODUCT PRESSURE Gauge**

The PRODUCT PRESSURE gauge indicates the pressure of oxygen coming out of the adsorber beds (See Figure 4.2).

## 4.3 Oxygen Concentrator Parts

Figure 4.3 and Figure 4.4 shows the internal components of the CENTOX oxygen concentrator

### 4.3.1 Compressor Enclosure

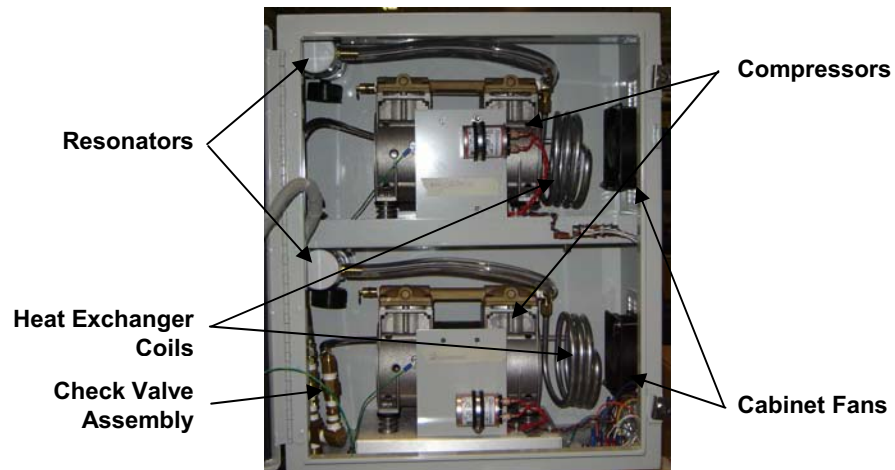

*Figure 4.3: Compressor Enclosure Internal Components*

#### Compressors

The compressors compress the air entering the enclosure before it is supplied to the PSA enclosure (See Figure 4.3).

#### Cabinet Fans

The cabinet fans provide internal cooling for the air compressor. Fans also help in better circulation of the air inside the compressor enclosure (See Figure 4.3).

#### Compressor Intake Filter

This filter provides additional filtration for the air as it enters the air compressor. This filter is attached to the gray PVC pipe. The complete assembly of the PVC pipe and the filter is called resonator (See Figure 4.3).

#### Heat Exchanger

The heat exchanger coils cool the compressed air leaving the compressor enclosure (See Figure 4.3).

#### Check Valve Assembly

Check Valve assembly prohibits the back flow of compressed air.

### 4.3.2 PSA Enclosure

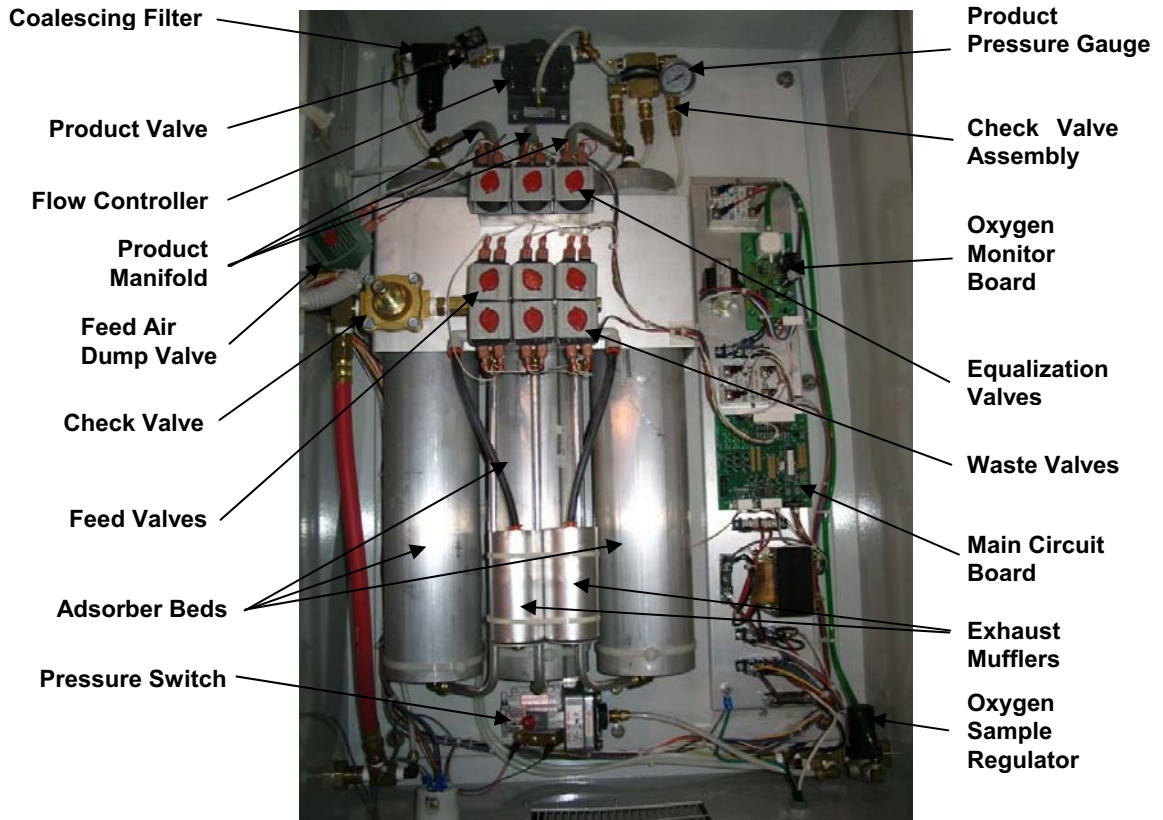

Figure 4.4: PSA Enclosure Internal Components

#### Adsorber Beds

The adsorbers contain the molecular sieve that adsorbs (attracts) nitrogen from compressed air and allows oxygen to pass through as product gas (See Figure 4.4).

#### Main Circuit Board

Main circuit board provides signal to all the valves based on the status of the oxygen generator.

#### Feed Air Dump Valve

The solenoid-operated valve is used to dump the compressed feed air for 3-5 sec at the initial start-up and 1 sec at the start of standby mode. This removes any pressure that builds up inside the compressor to ensure easy start-up.

#### Check Valve

Check Valve assembly prohibits the back flow of compressed air.

### **Feed Valves**

The automatic feed air valves control the flow of the feed air as the air enters the adsorbers (See Figure 4.4).

### **Waste Valves**

The automatic waste valves control the flow of waste gas as it exits the adsorbers (See Figure 4.4).

### **Exhaust Mufflers**

The mufflers muffle the noise produced by the waste gas that vents through the beds (See Figure 4.4).

### **Product Manifold**

Product manifold facilitates the oxygen flow across adsorber beds (from top of the adsorber beds) and to the product delivery line.

### **Equalization Valves**

The equalization valves on the product manifold controls the flow of oxygen from one bed to another during various steps of the oxygen generation process (See Figure 4.4).

### **Check Valves Assembly**

The check valve assembly supplies the product oxygen to the flow controller. See Figure 4.4.

### **Product Pressure Gauge**

Product pressure gauge mounted on the check valve assembly (See Figure 4.4) displays the pressure of the product oxygen.

### **Flow Controller**

The flow controller regulates the flow of oxygen (See Figure 4.4).

### **Product Valve**

The valve prevents the supply of oxygen when the unit is in standby mode (Refer to section 6 for the description of different types of mode). See Figure 4.4 for the location of the product valve.

### **Coalescing Filter**

The coalescing filter serves as bacteria filter and removes any bacteria present in the oxygen supply (See Figure 4.4).

### **Oxygen Monitor Board**

The oxygen sensor monitors the purity supplied from the PSA enclosure. If the oxygen purity decreases below the set point, low purity light on the PSA enclosure will be on. If the problem persists for more than 30 minutes, a low purity alarm will sound.

### **Oxygen Sample Regulator**

A regulator before the oxygen monitor board regulates the pressure to 4-5 psig to the oxygen monitor board. Refer to the section 7 for the regulator adjustment.

### **Pressure Switch**

When the oxygen concentrator operates in Auto mode, the pressure switch monitors the oxygen pressure at the outlet of the oxygen concentrator. When the pressure at the oxygen concentrator outlet increases to the pressure switch upper setpoint, the pressure switch circuit closes and the oxygen concentrator starts a timed shutdown that stops the unit at the end of the shutdown sequence (After 10 additional cycles). When the pressure at the oxygen concentrator outlet decreases to the lower setpoint of the switch, the pressure switch opens to activate the oxygen concentrator and the oxygen production begins. When the oxygen concentrator operates in Manual mode, the pressure switch circuit remains open and the oxygen concentrator cycles continuously. Refer to the appendix A of the manual for lower and upper setpoint settings of the pressure switch.

## 4.4 Auxiliary Kits Information (Optional)

The items discussed in this section are supplied as ordered. Listed below are the different starter kits available as per the oxygen concentrator ordered.

| Unit #                | Kit #<br>(Customer<br>Supplied Tank) | Kit #<br>(AirSep<br>Supplied Tank) |
|-----------------------|--------------------------------------|------------------------------------|
| AS074-1 120 VAC/60 Hz | KI470-1<br>KI046-1                   | KI470-1<br>KI046-1<br>TA150-1      |
| AS074-2 240 VAC/50 Hz | KI470-1<br>KI046-1                   | KI470-1<br>KI046-1<br>TA150-1      |
| AS074-3 240 VAC/60 Hz | KI470-1<br>KI046-1                   | KI470-1<br>KI046-1<br>TA150-1      |

*Table 4.1: Optional Starter Kits for the Concentrator Purchased*

| Kit #   | Description   | Qty. |
|---------|---|------|
| KI046-1 | Primary/Secondary Ball Valve Assembly                 | 1    |
|         | Hose Assembly, Oxygen-clean, (Secondary Hose)         | 1    |
| KI470-1 | Regulator-Flowmeter Assembly                          | 1    |
|         | Hose Assembly, Oxygen-clean (Main Oxygen Outlet Hose) | 1    |
| TA150-1 | 60 Gallon Tank Assembly, O <sub>2</sub> Cleaned       | 1    |

*Table 4.2: Description of the Parts included in the Starter Kits*

Please contact AirSep Corporation Sales representative for ordering the starter kits. Below is a brief description of item included in the starter kits.

### Primary Oxygen Ball Valve

The primary oxygen ball valve controls the flow of oxygen from the oxygen concentrator to your oxygen distribution system. See Figure 5.1.

### Secondary Oxygen Ball Valve

The secondary oxygen ball valve controls the flow of a backup source of oxygen to your oxygen distribution system. This ball valve should always be closed unless a backup source is connected to it. See Figure 5.1.

### Regulator-Flowmeter Assembly

This assembly consists of a pressure regulator and a flowmeter. The pressure regulator attaches to the outlet port of the oxygen receiver to regulate the pressure of the oxygen. The flowmeter is used to regulate



the flow of the oxygen at the outlet of the oxygen receiver. Refer to figure 5.1 for the installation location of this assembly.

### **Oxygen Isolation Ball Valve Assembly**

The oxygen isolation ball valve stops the flow of oxygen to the oxygen receiver during troubleshooting. The oxygen relief valve in the assembly prevents excess pressure from building in the oxygen receiver if a system malfunction occurs. This assembly is shipped mounted on the oxygen receiver. See Figure 4.5.

### **Main Oxygen Hose**

An oxygen-clean hose is provided that connects the outlet of the supply valve assembly (Refer to section 4.5) on the oxygen concentrator to the oxygen isolation ball valve assembly on the oxygen receiver.

### **Secondary Oxygen Hose**

Secondary hose is provided to connect the outlet of the regulator-flowmeter assembly to the inlet of the primary oxygen ball valve. Refer to Figure 5.1.

### **Oxygen Receiver**

The oxygen receiver stores oxygen produced by the oxygen concentrator. It also provides stable flow and purity for short-term surges of oxygen that exceed the rated capacity of the oxygen concentrator.

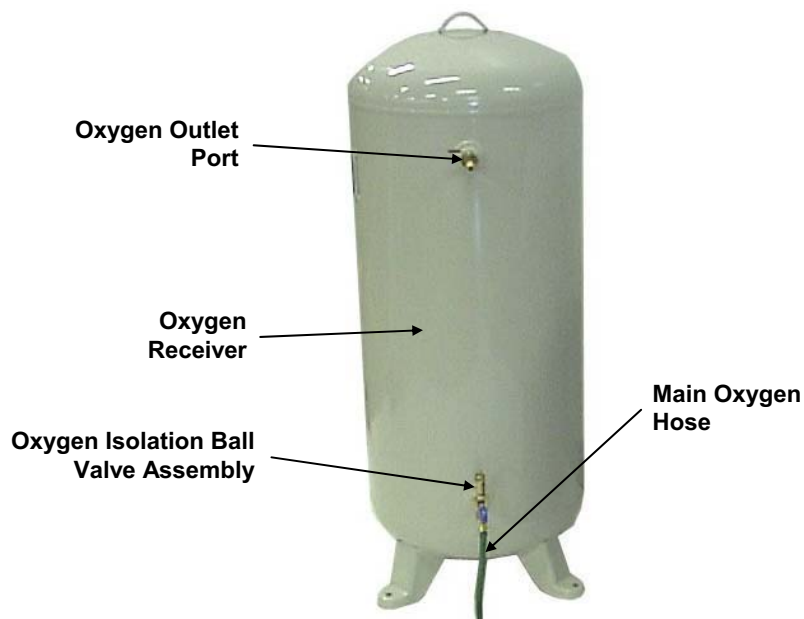

**Figure 4.5: Oxygen Receiver**

## **4.5 Connections**

### **Supply Valve Assembly**

This assembly is shipped loose and must be connected to the PSA enclosure oxygen outlet. The supply valve assembly limits the amount of flow to the oxygen receiver during purge. Refer to Figure 5.1 and 6.1.

### **Power Cord**

This power cord and its grounded electrical plug supply power to the CENTROX when connected to a grounded electrical outlet.

## 5.0 Installation

### 5.1 Unpacking

AirSep Corporation ships CENTROX Oxygen Concentrators on a wooden skid covered with corrugated cardboard. This container includes an accessory kit with an instruction manual and all the items necessary to properly install the oxygen concentrator. The oxygen receiver (if supplied) is shipped separately. Contact your AirSep Corporation's Sales representative for ordering the auxiliary kits supplied with the CENTROX oxygen concentrator.

AirSep recommends that you follow these unpacking guidelines carefully to protect yourself against loss from any damage caused during shipment.

1. Inspect the exterior for damage. If you observe any damage, note it on the freight bill or the express receipt before you sign it.



Failure to note exterior damage on the freight bill or the express receipt at the time of delivery can result in the carrier's refusal of a damage claim.

2. Carefully cut and remove any banding straps from the container. Then remove the corrugated cardboard.



Remove the corrugated cardboard very carefully. You may need to return the oxygen concentrator if it was damaged during shipment

3. Remove the oxygen concentrator from the wooden skid.
4. Thoroughly inspect the oxygen concentrator interior and exterior for damage caused during shipment. Pay special attention to the cabinet switches, gauges, brackets, etc.
5. Remove the accessory kit and inspect the contents for damage.
6. Although the CENTROX is carefully inspected, tested, and packed, it can be damaged during shipment due to improper handling. If you find any concealed damage (loss or damage not found until the

concentrator is unpacked), immediately call the delivery carrier and file a concealed-damage claim. Keep ALL container material and interior packing for the carrier's inspection.



**YOU MUST MAKE A CONCEALED-DAMAGE CLAIM WITHIN 24 HOURS OF DELIVERY.** Only the consignee can file this claim.



Follow these unpacking guidelines carefully to protect yourself against loss from any damage caused during shipment.

## 5.2 Pre-Installation Guidelines

Before you install the CENTROX oxygen concentrator, and the oxygen receiver, if supplied, refer to the Specifications section in the Appendix of this instruction manual to determine the applicable space, and the power requirements for your particular model.



A backup source of oxygen must be available if a power failure or system malfunction occurs.



Make sure the area that surrounds the oxygen concentrator is well ventilated, and provide sufficient space around the unit [at least three feet] to allow for cool air flow as well as to allow safe operation and maintenance.



Locate the oxygen concentrator in an area where the ambient air temperature remains between 4°C (40°F) and 40°C (104°F) to prevent damage not covered under the AirSep Corporation Product Warranty.



Connect the oxygen concentrator power cord only to a properly grounded electrical outlet on a circuit that cannot be accidentally turned off. Do not use extension cords.



Provide proper voltage to the oxygen concentrator to prevent damage not covered under the AirSep Product Warranty.



Do not plug in the power cord until you complete the installation of the oxygen concentrator.

## 5.3 Installation Instructions

To assure proper installation and safe operation of your CENTROX PSA Oxygen Concentrator, AirSep Corporation recommends that you review this entire section before you attempt to install the unit.



Do not turn off power to any component unless you are sure the medical facility does not require any oxygen, or there is a sufficient alternative/backup source of oxygen.



Before you attempt to install, operate, or repair the oxygen concentrator, read and thoroughly understand this instruction manual. Improper operation can result in severe bodily injury, damage to the system, or poor performance.

Refer to the Figure 5.1 as you follow the installation instructions:

1. Place the oxygen concentrator near the inlet of your oxygen distribution system.
2. Mount both the enclosures securely to a wall, ensuring that there is a minimum of two feet between the two enclosures and minimum of three feet between the compressor enclosure and a wall. The compressor enclosure can be on either side of the PSA enclosure.
3. Open the compressor enclosure and remove the tie wrap from each compressor. The tie wrap holds the compressor to a bracket support for shipping purpose.
4. Attach the red air hose from the compressor enclosure to the fitting on the left hand side of the PSA enclosure (See Figure 4.5 and 5.1).



The supply valve assembly at the outlet of the oxygen concentrator has a small hole drilled in it and allows a controlled amount of flow during purging process (See Section 6) of the 60 gallon tank (If supplied).

5. Mount the supply valve assembly (shipped loose) at the outlet of the PSA enclosure. Refer to Figure 5.1 and 6.1.
6. Attach the main oxygen hose from the supply valve to the inlet of the oxygen isolation ball valve assembly at the oxygen tank (See Figure 4.5 and 5.1).

7. Attach the regulator-flowmeter assembly at the outlet of the oxygen receiver.
8. Connect the inlet of the primary oxygen ball valve to the outlet of the regulator-flowmeter assembly (See Figure 5.1) with the secondary oxygen hose.

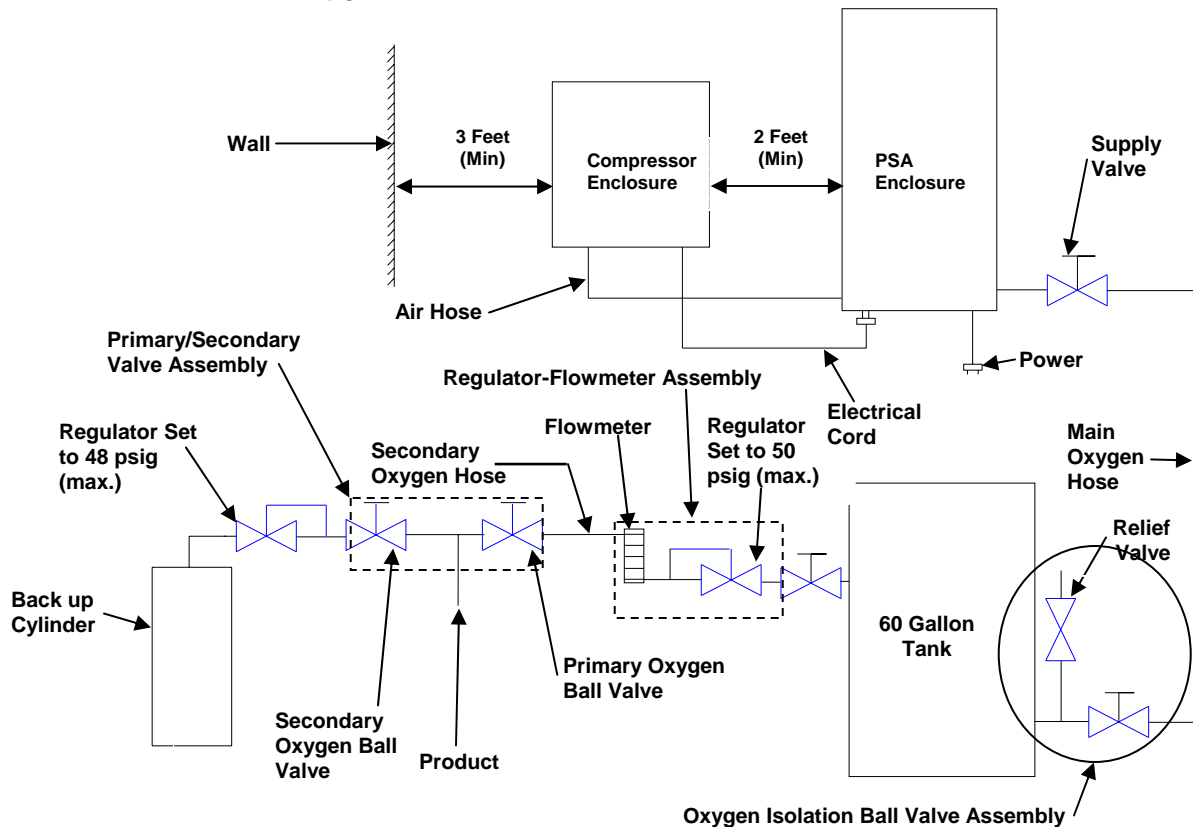

**Figure 5.1: General Arrangement of the CENTROX concentrator**

9. Attach a regulator set at 48 psig (not supplied by AirSep Corporation) to the outlet of the backup cylinder.
10. Connect the inlet of the secondary oxygen ball valve to the outlet of the above regulator using oxygen-clean hose.
11. Attach the center fitting of the primary/secondary ball valve assembly 'T' to your distribution system. The flowrate setting of the flowmeter should not exceed the value specified in the Appendix A of the manual.
12. Plug the electrical cord coming out of the compressor enclosure to the PSA enclosure as shown in the Figure 5.1.
13. Plug the cord from the PSA enclosure into the power supply outlet.
14. Make sure that the secondary ball valve is closed.





## 6.0 Operation

### 6.1 Initial Start-Up



Before you attempt to install, operate, or repair the CENTROX Oxygen Concentrator, read and thoroughly understand this instruction manual. Improper operation can result in severe bodily injury, damage to the system, or poor performance.



Oxygen vigorously accelerates the burning of combustible materials. In an oxygen-enriched atmosphere, many materials that do not burn in normal air require only a slight spark or moderate heat to set them aflame.

To avoid a fire or an explosion, keep gasoline, kerosene, oil, grease, cotton fibers, paint, and any other combustible material away from any part of the oxygen concentrator.

Do not smoke or use any open flame near the oxygen concentrator or oxygen receiver.

Post "NO SMOKING OR OPEN FLAMES" signs in the area where the components are located. AirSep STRONGLY recommends that only individuals trained and experienced in the safe handling of oxygen operate this system.



Before the CENTROX can supply oxygen within purity specifications, you must purge all air from the oxygen receiver(s).



Provide proper voltage to the oxygen concentrator to prevent damage not covered under the AirSep Product Warranty.



When you turn the oxygen concentrator on for the first time, it can take 20-30 minutes for the oxygen purity to reach the specification.

1. Observe that the ON/OFF switch on the PSA enclosure is in the off position.
2. Insert the compressor enclosure electrical plug to the electrical inlet at the bottom of the PSA enclosure. Refer to Figure 5.1.
3. Connect the PSA enclosure power cord to a properly grounded electrical outlet that cannot be accidentally turned off. Do not use extension cords.



If a power light is off, first check the electrical connection and then the oxygen concentrator circuitry. If this condition still exists, refer to the Troubleshooting section.

4. Set the AUTO/MANUAL switch on the PSA enclosure to the MANUAL position.
5. Ensure that oxygen isolation ball valve is open (See Figure 5.1).



If the unit is equipped with an oxygen monitor, the oxygen monitor light on the control panel remains on until the oxygen purity reaches 85%  $\pm$ 3%. The oxygen monitor alarms intermittently after 30 minutes if the CENTROX does not reach proper oxygen purity. During start-up, this alarm is silenced for 30 minutes.



Air exhausts for 3-5 seconds from the feed air dump valve (See Figure A.1). This is normal. It removes any pressure that builds up inside the compressor to ensure easy start-up.

6. Close the primary and the secondary oxygen ball valves (See Figure 5.1).
7. Remove the hose that connects the center fitting of the primary/secondary ball valve assembly to your distribution system. This will allow the air in the tank to be vented to the atmosphere.
8. Put the supply valve in the closed position (See Figure 6.1).



There is a small hole drilled in the supply ball valve to allow a controlled amount of gas to flow into the tank receiver when the valve is in the closed position. Figure 6.1 illustrates the opened and closed position of this valve.

9. Set both the ON/OFF switches on the compressor enclosure in the 'ON' position.
10. Set the PSA enclosure's ON/OFF switch to the ON position. At this stage, all the green ON/OFF switches should be ON.
11. Open the primary oxygen ball valve.
12. Fully open the regulator and flowmeter (See Figure 5.1). Oxygen should start coming out of the outlet once the regulator and flowmeter are open.
13. Allow the unit to run to purge air out of the tank and to achieve the minimum purity level of the oxygen as specified in the appendix A of the operating manual. This step may take 20-30 minutes.
14. Make sure that the minimum purity level of the oxygen as specified in the appendix A of the operating manual has been reached (the low purity light and the alarm goes off).
15. Fully close the primary oxygen ball valve (See Figure 5.1).
16. Set the AUTO/MANUAL switch on the PSA enclosure to the AUTO position.
17. Allow the oxygen receiver to attain a pressure of 55-65 psig. Make sure oxygen concentrator enters the standby mode and the yellow AUTO/MANUAL light shuts off.
18. Fully open the supply valve on the PSA enclosure.
19. Make sure that the regulator at the outlet of the oxygen tank is set at 50 psig (Open the primary oxygen ball valve slightly to adjust the regulator).
20. Close the primary oxygen ball valve and reattach the hose to the distribution system.
21. Open the primary oxygen ball valve.
22. Allow 15 LPM (max.) to flow through the flowmeter.
23. Make sure that the regulator at the outlet of the backup oxygen supply is set at 48 psig.
24. Open backup cylinder isolation valve (secondary oxygen ball valve).
25. Check all fittings and connections for leaks.

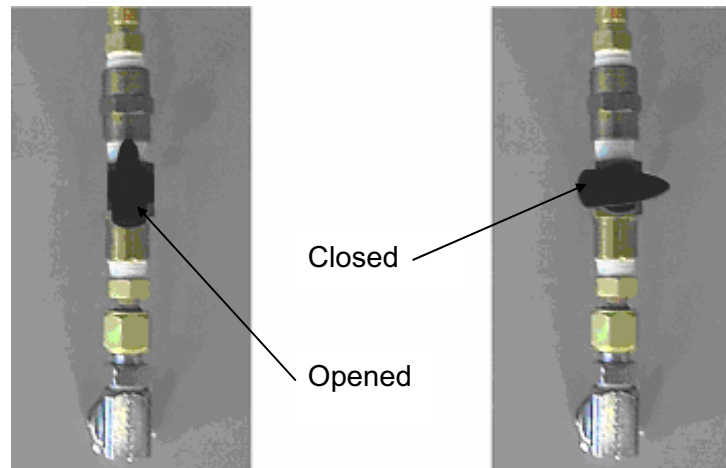

**Figure 6.1: PSA Enclosure Supply Valve Assembly**

## 6.2 Operation

### AUTO Mode

With the AUTO/MANUAL switch on the PSA enclosure's panel in the *AUTO* position, the oxygen concentrator cycles on and off automatically based on oxygen demand. When the PRODUCT PRESSURE gauge increases to the approximate pressure switch maximum pressure specified in this instruction manual, oxygen production stops after ten cycles and enters the **Standby mode**. At this stage, the yellow indicator light on the AUTO/MANUAL switch shuts off. When the pressure of the oxygen coming out of the adsorber beds decreases to approximately the pressure switch minimum pressure specified in this instruction manual, the oxygen concentrator resumes oxygen production and the yellow indicator light on the AUTO/MANUAL switch illuminates. The AUTO mode enables the most energy-efficient operation of the oxygen concentrator. Use the AUTO mode during normal operation and to shut down the oxygen concentrator.

### MANUAL Mode

With the AUTO/MANUAL switch on the oxygen concentrator control panel in the *MANUAL* position, the oxygen concentrator cycles continuously, regardless of the pressure fluctuations. Use the MANUAL mode during initial start-up or start-up after an extended shutdown of the oxygen concentrator and, depending on the oxygen flow, pressure, and purity requirements of your application, as directed by your AirSep Corporation representative.

## 6.3 Shutdown



Do not turn off power to the oxygen concentrator unless you are sure that the facility does not require any oxygen, or there is a sufficient alternative/backup source of oxygen.

1. Close the primary oxygen ball valve.
2. Observe that the AUTO/MANUAL switch is in the AUTO position, and wait until the yellow light shuts off and the CENTROX concentrator enters the standby mode.
3. Set the ON/OFF switch on the PSA enclosure to the OFF position.
4. Set the ON/OFF switches on the compressor enclosure to the OFF position.
5. Close the oxygen isolation ball valve (See Figure 5.1).



Failure to wait until the yellow light on the AUTO/MANUAL switch automatically shuts off will result in lower purity oxygen during subsequent startup.

## 6.4 Normal Start-Up

1. Make sure the AUTO/MANUAL switch is in the AUTO position and the ON/OFF switch's green power light is on.
2. Ensure that the oxygen isolation ball valve is open (See Figure 5.1).
3. Set the ON/OFF switch on the compressor enclosure to the ON position.
4. Set the ON/OFF switch on the PSA enclosure to the ON position.
5. Open the primary oxygen ball valve.

## 6.5 Start-Up after an Extended Shutdown

When the CENTROX oxygen concentrator is turned on after an extended shutdown, the oxygen receiver may be full of air or low purity oxygen. Before the CENTROX can supply oxygen within purity specifications, you must purge all air from the oxygen receiver. To do this, follow all steps described in Section 6.1.



Using the oxygen generator at flows higher than 15% above those specified in Appendix A of this manual, will result in the likely contamination of the molecular sieve beds. This damage is not covered under the standard warranty.

## 7.0 Maintenance/Service

To ensure the long life of your CENTROX Oxygen Concentrator, maintain the unit as described in the following sections. Follow the procedures described in this section of the instruction manual for daily, semi-annual, and annual maintenance.

| Time Period | Action  |
|-------------|---|
| Weekly      | Remove and wash air intake filters.   |
| Semi-Annual | Clean Compressor intake filters.  |
| Annually    | Replace coalescing filter element. The filter element should be changed if found very dirty even if one year time period has not elapsed. |
|             | Check performance of all the solenoid valves. Replace or rebuild as necessary.  |
| 12000 hours | Rebuild the feed air compressor.  |

*Table 7-1 Maintenance Chart*

Foreign particles in the feed air affect the operation of the oxygen concentrator. The filters supplied in the concentrator are factory-selected based on the unit's air requirements and average air conditions.



The interior of the CENTROX Oxygen Concentrator contains electrical parts that can produce an electrical hazard if not handled properly. To prevent electrical shock, use extreme care when you service the system.



AirSep selects concentrator filters based on their ability to perform in severe conditions. Use of other than Original Equipment Manufacturer filters/elements can cause damage not covered under the AirSep Product Warranty.



Failure to maintain the air intake and compressor intake filters can allow foreign particles in the air to enter the oxygen concentrator and cause damage not covered under the AirSep Product Warranty.

## 7.1 Weekly Maintenance

Once every seven days. (Remove the air intake filters (See Figure 4.1) from the left side of the compressor enclosure and wash it with soap and water.)

## 7.2 Semi-Annual Maintenance

### 7.2.1 Cleaning the Compressor Intake Filters

Once every six months or as often as necessary, use the following procedure to clean the compressor intake filters.

1. Close the primary oxygen ball valve.
2. Observe that the AUTO/MANUAL switch is in the AUTO position, and wait until the yellow light shuts off.
3. Set the ON/OFF switch to the OFF position on both the enclosures.
4. Unplug the unit from main power supply.
5. Open the compressor enclosure.
6. Pull up on the black cap on the compressor intake filter housing to remove it. This is attached to the gray PVC pipe (See Figure 4.3: Resonator).
7. Remove and wash the foam insert with soap and water.
8. Replace the foam insert.
9. Replace the black cap.
10. Close the compressor enclosure.
11. Follow all steps in Section 6.1 – Initial Start-up.

### 7.2.2 Adjusting the Oxygen Sample Regulator



Ensure that the backup supply of oxygen is present with the secondary oxygen ball valve open, if oxygen is needed while adjusting the oxygen monitor regulator.

1. Close the primary oxygen ball valve.
2. Observe that the AUTO/MANUAL switch is in the AUTO position, and wait until the yellow light shuts off.



3. Set the ON/OFF switch on the PSA enclosure to the OFF position.
4. Open the PSA enclosure.
5. Pull outward on the oxygen monitor regulator knob and turn it fully counterclockwise.
6. Disconnect the tubing at the oxygen sample regulator. See Figure 4.4 for location of oxygen sample regulator.



**NOTE**

Remove any tie-wraps from the tubing before you disconnect it.

7. Connect the tubing from regulator pressure test kit# KI488-1 to oxygen sample regulator.
8. Set the AUTO/MANUAL switch to MANUAL position
9. Set the ON/OFF switch to ON position.



**WARNING**

The interior of the Centrox Oxygen Concentrator contains electrical parts that can produce an electrical hazard if not handled properly. To prevent electrical shock, use extreme care when you service the system.

10. Adjust the knob on the oxygen sample regulator until the gauge registers 4-5 psig.
11. Lock the oxygen sample regulator knob by pressing it. Confirm the setting after locking the regulator.



**CAUTION**

Do not set the oxygen sample regulator above 5 psig as it may create an overdrawing condition and result in low purity oxygen alarm.

12. Set the ON/OFF switch to the OFF position.
13. Remove the oxygen regulator pressure kit tubing from the oxygen sample regulator.
14. Reconnect the tubing from oxygen monitor board to the oxygen sample regulator.
15. Secure the tubing with new tie-wraps.
16. Close the PSA enclosure.
17. Follow all steps in Section 6.1 (Initial Start-up).

## 7.3 Annual Maintenance

The expected life of the coalescing filter element is approximately 12 months. Failure to replace the filter element on schedule results in a void AirSep Product Warranty.



**CAUTION**

AirSep selects concentrator filters based on their ability to perform in severe conditions. Use of other than Original Equipment Manufacturer filters/elements can cause damage not covered under the AirSep Product Warranty.



**CAUTION**

Failure to maintain the air intake and compressor intake filters can allow foreign particles in the air to enter the concentrator and cause damage not covered under the AirSep Product Warranty.

### 7.3.1 Coalescing Filter Element Replacement

The coalescing filter is located inside the PSA enclosure (See Figure 4.4). It removes any foreign particles present in the oxygen supply.



**NOTE**

Order the element to be replaced through the AirSep Industrial Service Department. Specify Part Number FI018-1, cleaned for oxygen service. Contact AirSep Monday through Friday, from 8:00 a.m. to 4:00 p.m. Eastern Standard Time/USA or Canada, at 1-800-320-0303 or (716) 691-0202 outside of the USA/Canada.

1. Wash your hands thoroughly, and make sure they are oil-free before you begin this procedure.



**WARNING**

Oxygen can cause spontaneous combustion, and as such, is a fire hazard. Make sure that no flammable materials are located in the oxygen concentrator area designated "Oxygen in Use — No Smoking."

2. Close the primary oxygen ball valve. See Figure 5.1 for location of this valve.

3. Observe that the AUTO/MANUAL switch is in the AUTO position, and wait until the yellow light shuts off.
4. Set the ON/OFF switch of the PSA enclosure to the OFF position.
5. Close the oxygen isolation ball valve. See Figure 5.1 for location of this valve.
6. Unplug the PSA enclosure power cord from the electrical outlet.
7. Open the PSA enclosure.
8. Push up on the pin or unscrew the plastic nut (whichever applicable) on the bottom of the filter bowl.



Pressure releases when you push up on the pin or unscrew the plastic nut (whichever applicable) on the filter bowl.

9. When the PRODUCT PRESSURE gauge registers 0 psig, the unit is depressurized.
10. When the unit is depressurized, replace the filter element.
11. To gain access to the element, you must remove the filter bowl. Unscrew the bowl counterclockwise to remove it. Use one hand to steady the filter head while removing the bowl with the other to ensure you do not loosen the fittings and hoses connected to the sides of the filter.
12. Unscrew the filter element, and remove the O-ring. Replace the element and the O-ring with new one, taking care to ensure that ring remains oil- and grease-free. Reconnect the bowl to the filter body. Use one hand to steady the filter head while making sure the filter bowl is completely screwed on with the other.
13. Follow all the steps in Section 6.1 (Initial Start-up)
14. Leak test the coalescing filter assembly.

## 7.4 Pressure Switch Adjustment Procedure

In the Centrox units, typically the normally open contact of the pressure switch is used for the wiring purposes. Please refer to the Figure 7.1 for the following adjustment procedure:

1. If the oxygen concentrator is in the line of the final application when adjustment (signal setting) is made to the pressure switch, be sure

that the switch can be test operated without effecting the other equipment.

2. Remove switch cover, if any.
3. Turn adjusting nut at top of the switch clockwise until setting indicator is fully up. Turn deadband adjusting knob on front of the switch clockwise as far as possible. Refer to Figure 7.1.



Adjusting nut and knob will turn easily until they hit a stop. Do not over torque. Over torque may cause damage.

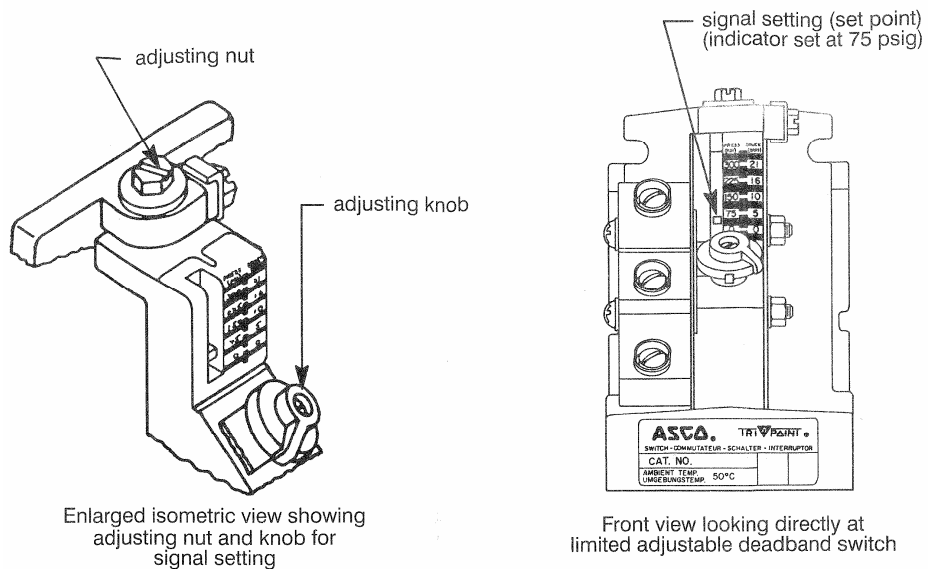

**Figure 7.1: Pressure Switch**

4. Follow the steps in the chart below to make signal settings.

| Adjustment Procedure   | Normally Open                   |                              |
|--|---------------------------------|------------------------------|
|  | Electrical Connection to Switch | Position of Test Lamp On-Off |
| 1. Starting with zero signal, connect the test lamp to common. | Normally Open Terminal          | Off (Open Circuit)           |
| 2. Apply desired actuation pressure. Then back off             | Normally Open                   | On (Closed)                  |

|   |                        |                    |
|---|------------------------|--------------------|
| (counter-clockwise) top adjusting nut until switch actuates (set point increasing).   | Terminal               | Circuit)           |
| 3. Lower pressure to desired reactivation signal. Then turn deadband adjusting knob counterclockwise until switch reactivates (set point decreasing). | Normally Open Terminal | Off (Open Circuit) |

5. Cycle pressure between two desired signals and make minor adjustments to adjusting nut and knob as required to achieve exact set points.



If the adjustment of the switch has been made when the oxygen concentrator is not in the line of final application, the switch should be retested when installed in the final line of application. Follow adjustment instruction. Be sure switch can be test operated without affecting the other equipment.



## 8.0 Troubleshooting

The AirSep CENTROX Oxygen Concentrator runs pressurized during normal operation. **You must depressurize the unit BEFORE you attempt any REPAIRS.**

Use the following procedure to depressurize the oxygen concentrator safely.

1. Shut down the oxygen concentrator as described in Section 6.3.
2. To depressurize the concentrator, follow the steps in the Coalescing Filter Element Replacement procedure in Section 7.3.1.



**NOTE**

If the unit needs to be pressurized to troubleshoot it, close the oxygen isolation ball valve and primary oxygen ball valve and let the unit run in the AUTO position while the ON/OFF switch is in the ON position. Make sure you open the oxygen isolation ball valve and primary oxygen ball valve after you complete the troubleshooting.

3. The PRODUCT PRESSURE gauge should now register 0. If it does not, stop and contact your nearest AirSep Service Representative or the AirSep Industrial Service Department for further instructions.

Contact the AirSep Industrial Service Department by phone Monday through Friday between 8:00 a.m. and 4:00 p.m. Eastern Standard Time/USA or Canada at **1-800-320-0303** or **(716) 691-0202** outside of the USA/Canada.

Send fax inquiries anytime to **(716) 691-1255**.

Address written inquiries to:

AirSep Corporation  
401 Creekside Drive  
Buffalo, NY 14228-2085 USA  
Attention: Commercial Products Service Department

Send e-mail inquiries to **[cpdservice@airsep.com](mailto:cpdservice@airsep.com)**

Visit [www.airsep.com](http://www.airsep.com) to learn about our complete range of standard Oxygen Generators.

4. Proceed to determine and repair the problem.
5. When you complete the repair, start up the oxygen concentrator as described in Section 6.1 – Initial Start-up.

## 8.1 Troubleshooting Chart

The chart on the following pages is a guide for troubleshooting the AirSep CENTROX Oxygen Concentrator.



The interior of the oxygen concentrator contains electrical parts that can produce an electrical hazard if not handled properly. To prevent electrical shock, use extreme care when you service the system.



The Printed Circuit Boards (PCBs) contain components that are sensitive to electrostatic discharge (ESD) and can be damaged if not handled properly. As when handling any ESD-sensitive PCB, observe standard ESD safety procedures. These procedures include the following:

- Handle the PCB only by the edges.
- Work on a grounded ESD mat.
- Wear a grounded wrist strap.
- Store PCBs only in anti-static bag.



| <b>Problem</b>   | <b>Probable Cause</b>  | <b>Solution</b>   |
|--|--|---|
| Oxygen compressor(s) do not start. No green power light.   | PSA enclosure not plugged to the power supply.                   | Plug in the PSA enclosure.  |
|  | Compressor enclosure not plugged in to the PSA enclosure.        | Plug in compressor enclosure to the PSA enclosure.                                |
|  | Tripped Circuit breaker(s).                                      | Reset circuit breaker(s).   |
|  | ON/OFF switches on the compressor enclosure are in OFF position. | Put the ON/OFF switches on the compressor enclosure in ON Position.               |
|  | ON/OFF switch on the PSA enclosure in OFF position.              | Put the ON/OFF switch on the PSA enclosure in ON Position.                        |
|  | Defective ON/OFF switch.   | Replace ON/OFF switch.  |
|  | Blown 3A or 15A fuse in PSA enclosure.                           | Replace the appropriate fuse.   |
|  | Faulty electrical connections.<br>Defective circuit board.       | Check electrical connections.<br>Replace circuit board. (Refer to Section 8.1.3). |
| Oxygen concentrator does not cycle. No green power light on the PSA enclosure.   | Unit not plugged in to the power supply.                         | Plug in unit to the electrical outlet.  |
|  | No power supply to the wall outlet.<br>Blown 15A fuse.           | Replace fuse or reset breaker.<br>Replace fuse.                                   |
| Oxygen concentrator does not cycle, but green power light is ON on the PSA enclosure. AUTO/MANUAL switch is set to MANUAL position, and yellow light is off. | ON/OFF switch is off.  | Set ON/OFF switch to ON position.   |
|  | Defective ON/OFF switch.   | Replace ON/OFF switch.  |
|  | Blown 3A fuse.   | Replace fuse.   |
|  | Defective AUTO/MANUAL switch.                                    | Replace AUTO/MANUAL switch.   |
|  | Defective power wire to circuit board.                           | Repair or replace wire.   |
|  | Low voltage condition.   | Call electric company.  |
|  | Defective transformer.<br>Defective circuit board.               | Replace transformer.<br>Replace circuit board.                                    |

| <b>Problem</b>   | <b>Probable Cause</b>                         | <b>Solution</b>   |
|--|---|---|
| Oxygen concentrator does not cycle. Green power light is ON on the PSA enclosure; AUTO/MANUAL switch is set to AUTO position. Yellow light is off. Product Pressure gauge registers less than 50 psig (205 kPa). | ON/OFF switch is set to OFF position.         | Set ON/OFF switch to ON position.                           |
|  | Defective ON/OFF switch.                      | Replace ON/OFF switch.                                      |
|  | Defective wire to circuit board.              | Repair or replace wire.                                     |
|  | Pressure switch improperly adjusted.          | Adjust pressure switch correctly. (Refer to Section 8.1.1.) |
|  | Defective pressure switch.                    | Replace pressure switch.                                    |
|  | Defective circuit board.                      | Replace circuit board.                                      |
| Oxygen concentrator turns on. Green power light on the PSA enclosure is not ON.  | Defective ON/OFF switch on the PSA enclosure. | Replace ON/OFF switch on the PSA enclosure.                 |
| Oxygen concentrator cycles, but yellow light does not turn ON. AUTO/MANUAL switch is set to AUTO position.   | Defective wire.                               | Repair or replace wire.                                     |
|  | Defective AUTO/MANUAL switch.                 | Replace AUTO/MANUAL switch.                                 |
|  | Defective circuit board.                      | Repair or replace circuit board.                            |

| Problem  | Probable Cause   | Solution  |
|--|--|---|
| <p>Oxygen concentrator cycles continuously.<br/>                     AUTO/MANUAL switch is set to AUTO position. Yellow light is ON. Oxygen Receiver Pressure gauge registers less than 50 psig (345 kPa).<br/>                     Oxygen purity is acceptable.</p> | <p>Compressor does not build up adequate pressure.</p>               | <p>Replace compressor.</p>  |
|  | <p>Compressor intake filter plugged.</p>                             | <p>Clean or replace compressor intake filter.</p>   |
|  | <p>Feed air dump valve leaks.</p>                                    | <p>Check all wires and connections (Refer to the wiring diagrams in Appendix A). If problem continues, replace the valve.</p> |
|  | <p>Compressor relief valve leaks</p>                                 | <p>Replace relief valve</p>   |
|  | <p>Air leak in system.</p>   | <p>Check oxygen concentrator. Repair as necessary.</p>  |
|  | <p>Oxygen usage is greater than capacity of oxygen concentrator.</p> | <p>Check oxygen usage. If usage exceeds system capacity (32 SCF/hr [15 lpm]), reduce usage.</p>                               |
|  | <p>Oxygen leak in system.</p>  | <p>Check oxygen concentrator and oxygen distribution system for leaks. Repair as necessary.</p>                               |

| <b>Problem</b>  | <b>Probable Cause</b>                                     | <b>Solution</b>   |
|---|---|---|
| Oxygen concentrator cycles continuously.<br>AUTO/MANUAL switch is set to AUTO position. Yellow light is on. Oxygen Receiver Pressure gauge registers 63 psig (435 kPa) or higher. | Pressure switch improperly adjusted.                      | Readjust pressure switch. (Refer to Section 8.1.1).   |
|   | Defective wire to AUTO/MANUAL switch.                     | Repair or replace wire to AUTO/MANUAL switch.   |
|   | Defective AUTO/MANUAL switch.                             | Replace AUTO/MANUAL switch.   |
|   | Defective wire to pressure switch.                        | Repair or replace wire to pressure switch.  |
|   | Defective pressure switch                                 | Replace pressure switch.  |
|   | Defective circuit board.                                  | Replace circuit board. (Refer to Section 8.1.3).  |
| Low purity oxygen (21-82%) temporarily after start-up. Alarm sounds. Oxygen monitor light illuminates.  | Incorrect initial start-up.                               | Refer to Start-Up procedure given section 6.1.  |
|   | Extended shutdown (oxygen receiver pressure registers 0). | Refer to Start-Up procedure given in section 6.1.   |
|   | Momentary power loss.                                     | Purge system. (Refer to Start-Up procedure.)  |
|   | Leaky feed air check valve.<br>Oxygen leak in system.     | Replace feed check valve.<br>Check oxygen concentrator and oxygen distribution system for leaks. Repair as necessary. |

| <b>Problem</b>  | <b>Probable Cause</b>                       | <b>Solution</b>   |
|---|---|---|
| Low purity oxygen (21-82%) continuously after start-up. Alarm sounds. Oxygen monitor light illuminates. | Oxygen System overdrawn.                    | Check the oxygen usage. The oxygen system must not be used beyond the rated capacity.           |
| Oxygen receiver pressure registers less than 50 psig (345 kPa).   | Defective solenoid valve.                   | Identify and rebuild valve.   |
|   | Defective wire to circuit board.            | Repair or replace wire.   |
|   | Oxygen leak in system.                      | Check oxygen concentrator for leaks. Repair as necessary.                                       |
|   | Leaky check valves in check valve assembly. | Clean or replace check valves.  |
|   | Plugged waste muffler.                      | Replace muffler.  |
|   | System does not cycle properly.             | Check all wires and connections. Repair as needed. If problem continues, replace circuit board. |
|   | Defective circuit board.                    | Replace circuit board. (Refer to Section 8.1.3).  |
|   | Compressor pressure not adequate.           | Replace compressor.   |
| Solenoid valve chatters loudly.   | Molecular sieve contaminated.               | Replace molecular sieve. Contact AirSep Industrial Service Department for assistance.           |
|   | Low voltage condition.                      | Check power supply.   |
|   | Dirty valve.                                | Clean or rebuild valve.   |
|   | Worn valve core.                            | Rebuild valve.  |
|   | Bad Coil.                                   | Replace Coil.   |
|   | Low voltage to valve from circuit board.    | Replace circuit board. (Refer to Section 8.1.3).  |

| <b>Problem</b>  | <b>Probable Cause</b>  | <b>Solution</b>  |
|---|--|--|
| Concentrator runs with intermittent alarm. Oxygen flow 32 SCF/hr (15 lpm). Purity is within specifications. | Oxygen sample regulator not set correctly.                       | Reset the regulator. Refer to section 7.2.2.           |
|   | Faulty electrical connection.<br>Defective oxygen monitor board. | Check electrical connection.<br>Replace monitor board. |

| <b>Problem</b>  | <b>Probable Cause</b>           | <b>Solution</b>   |
|---|---------------------------------|---|
| Concentrator runs with oxygen monitor light illuminated for more than 30 minutes. Audible alarm does not sound. Low purity oxygen (21-82%). | Faulty electrical connections.  | Check all wires and connections. (Refer to the wiring diagrams in Appendix A.) If problem continues, replace alarm board. |
|   | Defective alarm buzzer.         | Replace alarm buzzer.   |
| Concentrator runs with audible alarm for more than 15 minutes. Oxygen monitor light is not illuminated. Low purity oxygen (21-82%).         | Faulty electrical connections.  | Check all wires and connections. (Refer to the wiring diagrams in Appendix A.) If problem continues, replace alarm board. |
|   | Defective oxygen monitor light. | Replace oxygen monitor light.   |

### 8.1.1 Pressure Switch Troubleshooting

The pressure switch is located at the bottom of the PSA enclosure (Figure 4.4).

If the pressure switch does not work properly, review the following probable causes:

| Probable Cause                    | Solution   |
|-----------------------------------|--|
| Incorrect electrical connections. | Check leads to switch. Make sure they are properly connected.  |
| Faulty control circuit.           | Check electrical power supply to switch. Check for open-circuited or grounded wires and loose connections at terminal block or switch. |
| Incorrect adjustment.             | Check high and low adjustments for proper setting. (See Appendix D — Component Literature.)  |

If you cannot correct the operation of the pressure switch, replace the entire switch.

### 8.1.2 Solenoid Valve Troubleshooting

If a solenoid valve does not energize, review the following probable causes:

| Probable Cause           | Solution                  |
|--------------------------|---------------------------|
| Defective wire to valve. | Repair or replace wire.   |
| Defective coil.          | Replace coil.             |
| Defective valve.         | Rebuild or replace valve. |
| Defective circuit board. | Replace circuit board.    |

If a solenoid valve stays constantly energized then the circuit board is defective. Replace the circuit board.

To determine if a solenoid valve, main circuit board, or wire is defective, review the following:

#### Solenoid Valves

Set a voltmeter to DC, and carefully connect the leads to the two terminal spades on the coil of the solenoid valve. The voltmeter should register 100 VDC ±10% when energized, and 0 when de-energized.

### Feed Air Dump Valve

This valve is normally closed. A problem with the valve exists only if air constantly escapes from the outlet.



Whenever you start up the CENTROX, it is normal for air to escape from the feed air dump valve for 3-5 seconds.



If all of the solenoid valves receive the proper voltage but a solenoid valve still malfunctions, proceed to rebuild the valve.

If any valve, with the exception of the feed air dump valve, does not energize during normal operation:

1. Check the wires from the circuit board to the valves for defects.
2. If the problem still exists, check the solenoid valve coils. Replace coil, if found defective.
3. If the problem still exists, replace the circuit board.

### 8.1.3 Main Circuit Board Removal

1. Set the unit's ON/OFF switch of the PSA enclosure to the OFF position, and unplug the power cord.
2. Open the PSA enclosure.
3. Disconnect the connectors from the circuit board. If the unit has oxygen monitor installed, the main circuit board is the lower one (Figure 4.4).
4. Push in on the board support tabs with a slotted screwdriver while you pull each corner.
5. Remove the circuit board.





The Printed Circuit Boards (PCBs) contain components that are sensitive to electrostatic discharge (ESD) and can be damaged if not handled properly. As when handling any ESD-sensitive PCB, observe standard ESD safety procedures. These procedures include the following:

- Handle the PCB only by the edges.
- Work on a grounded ESD mat.
- Wear a grounded wrist strap.
- Store PCBs only in anti-static bag.

### 8.1.4 Main Circuit Board Installation



Handle the new circuit board only by the edges to prevent an electrostatic short.

1. Push the circuit board on to the four support tabs.
2. Firmly plug the connectors into the new circuit board so that the connectors' locking tabs lock against the circuit board.
3. Close the PSA enclosure.

### 8.1.5 Compressor Removal

To remove the compressor for exchange, follow the steps below:

1. Set the ON/OFF switch on both the enclosures to the OFF position, and unplug the power cord.
2. Close the oxygen isolation ball valve.
3. Open the compressor enclosure.
4. Remove the suction tube and the other end of the stainless steel hose that comes out from the compressor outlet.
5. Disconnect the two power cords from the terminal block and the two capacitor wires.
6. Also disconnect the ground wire from the compressor.

7. Remove the four bolts that connect the compressor plate to the base of the unit.
8. Slide out the compressor.



Take note of the assembly of the spring mounts. These components will need to be reinstalled when the new compressor is assembled.

9. Carefully place the compressor upside down, and remove the four bolts that connect the compressor to the mounting plate.
10. Carefully remove all the fittings from the compressor.

### **8.1.6 Compressor Installation**

To install a new compressor, follow the steps below:

1. Place the new compressor upside down.
2. Align the holes of the spring mount plates with the holes on the compressor.
3. Place the springs on the spring mount plates.
4. Place the compressor mounting bracket onto the springs.
5. Thread the four bolts into the compressor ensuring that all spring mount assembly parts are present.
6. Turn the compressor right side up. Make sure that the springs are centered on the black plastic bushings.
7. Thread the brass fittings and pressure relief valve into the compressor.
8. Follow the compressor removal procedure in reverse order.
9. Reconnect both side panels on the unit.

**A Appendix****Technical Data****Specifications**

Data in this section refer to the CENTROX oxygen concentrators. This data may vary as per the customer's requirements.

|                          |  |
|--------------------------|--|
| Oxygen output:           | 32 SCF/hr at 0–50 psig*<br>15 slpm at 0-345 kPa**  |
| Oxygen purity:           | USP 93%  |
| Oxygen dew point:        | -73°C (-100°F)   |
| Dimensions:              | 27 x 21 x 13 in. (H x W x D) (Compressor Encl.)<br>38 x 27 x 15 in. (H x W x D) (PSA Enclosure)  |
| Approximate weight:      | 100 lbs (Compressor Enclosure)<br>160 lbs (PSA Enclosure)  |
| Power requirements:      | 120 VAC ± 10%, 60 Hz, Single Phase<br>240 VAC ± 10%, 50 Hz, Single Phase   |
| Pressure Switch Setting: | For 120 VAC, 60 Hz power supply<br>Minimum: 58 psig<br>Maximum: 63 psig<br><br>For 240 VAC, 50 Hz power supply<br>Minimum: 52 psig<br>Maximum: 58 psig |

(Pressure switch setting may vary slightly based on the customer's requirements.)

\*SCF (Standard Cubic Foot) gas measured at 1 atmosphere and 70°F.

\*\*SLPM (Standard Litre Per Minute) gas measured at 1 atmosphere and 70°F.



## **Drawings and Schematics**



| LEGEND |                                   |
|--------|-----------------------------------|
| ITEM   | DESCRIPTION                       |
|        | MANUAL VALVE                      |
|        | SOLENOID OPERATED VALVE           |
|        | CHECK VALVE                       |
|        | PRESSURE GAUGE                    |
|        | DEMAND VALVE                      |
|        | PRESSURE REGULATOR                |
|        | FLOW CONTROL ORIFICE              |
|        | RELIEF VALVE                      |
|        | SOLENOID OPERATED PRESSURE SWITCH |
|        | ECO VALVE                         |

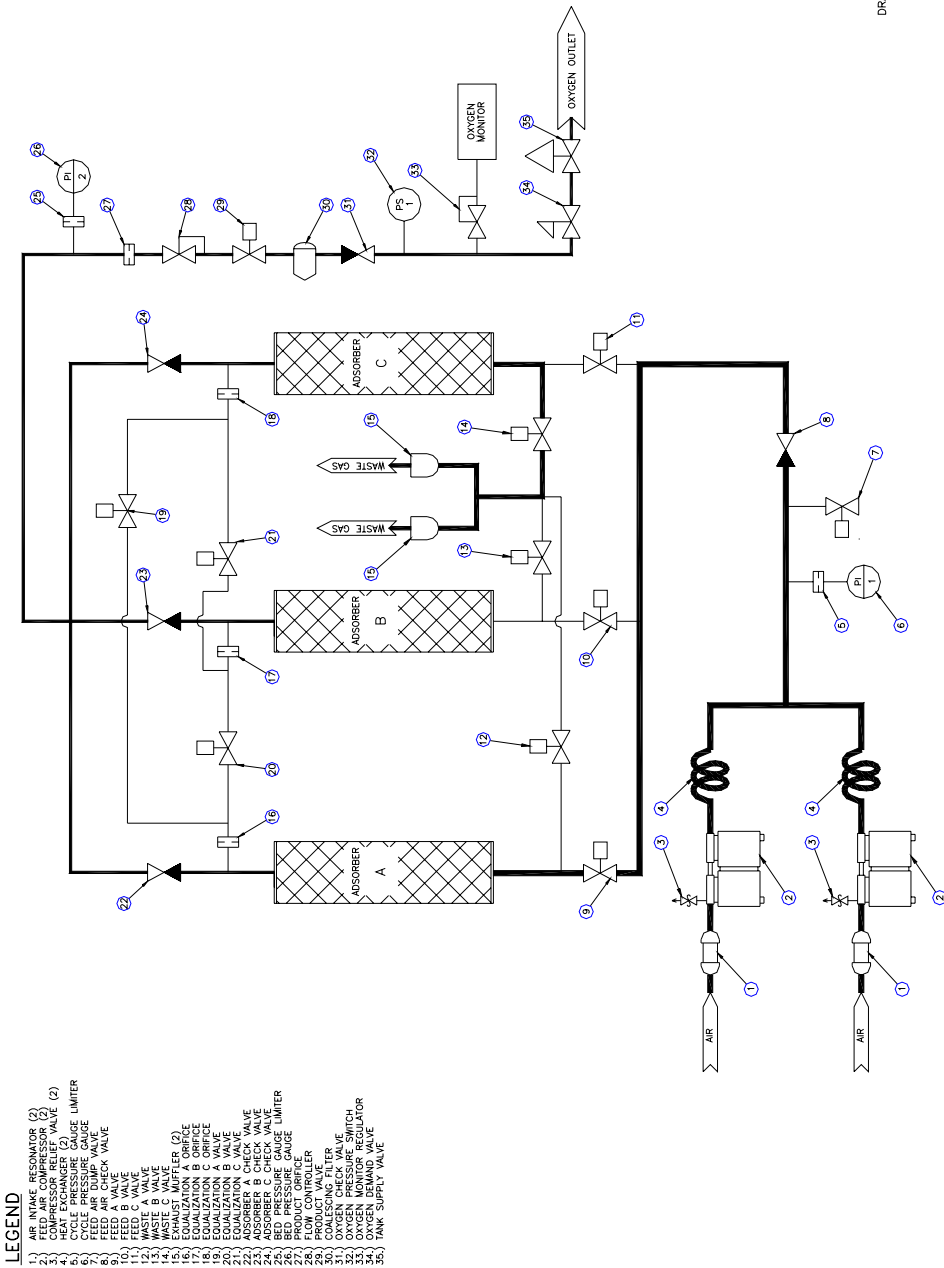

- LEGEND**
- 1.) AIR INLET COMPRESSOR (2)
  - 2.) COMPRESSOR RELIEF VALVE (2)
  - 3.) AIR INLET COMPRESSOR (2)
  - 4.) PRESSURE REGULATOR
  - 5.) CYCLE PRESSURE GAUGE LIMITER
  - 6.) CYCLE PRESSURE GAUGE
  - 7.) FEED AIR CHECK VALVE
  - 8.) FEED AIR CHECK VALVE
  - 9.) FEED A VALVE
  - 10.) FEED C VALVE
  - 11.) FEED A VALVE
  - 12.) FEED B VALVE
  - 13.) FEED C VALVE
  - 14.) WASTE GAS VALVE
  - 15.) WASTE GAS VALVE
  - 16.) WASTE GAS VALVE
  - 17.) EQUALIZATION B ORIFICE
  - 18.) EQUALIZATION B VALVE
  - 19.) EQUALIZATION A VALVE
  - 20.) EQUALIZATION A VALVE
  - 21.) EQUALIZATION B VALVE
  - 22.) EQUALIZATION B VALVE
  - 23.) ASSORBER A CHECK VALVE
  - 24.) ASSORBER B CHECK VALVE
  - 25.) ASSORBER C CHECK VALVE
  - 26.) RED PRESSURE GAUGE LIMITER
  - 27.) RED PRESSURE GAUGE
  - 28.) PRODUCT ORIFICE
  - 29.) OXYGEN OUTLET
  - 30.) FLOW CONTROLLER
  - 31.) FLOW CONTROL ORIFICE
  - 32.) FLOW CONTROL ORIFICE
  - 33.) FLOW CONTROL ORIFICE
  - 34.) FLOW CONTROL ORIFICE
  - 35.) FLOW CONTROL ORIFICE
  - 36.) FLOW CONTROL ORIFICE
  - 37.) FLOW CONTROL ORIFICE
  - 38.) FLOW CONTROL ORIFICE
  - 39.) FLOW CONTROL ORIFICE
  - 40.) FLOW CONTROL ORIFICE
  - 41.) FLOW CONTROL ORIFICE
  - 42.) FLOW CONTROL ORIFICE
  - 43.) FLOW CONTROL ORIFICE
  - 44.) FLOW CONTROL ORIFICE
  - 45.) FLOW CONTROL ORIFICE
  - 46.) FLOW CONTROL ORIFICE
  - 47.) FLOW CONTROL ORIFICE
  - 48.) FLOW CONTROL ORIFICE
  - 49.) FLOW CONTROL ORIFICE
  - 50.) FLOW CONTROL ORIFICE
  - 51.) FLOW CONTROL ORIFICE
  - 52.) FLOW CONTROL ORIFICE
  - 53.) FLOW CONTROL ORIFICE
  - 54.) FLOW CONTROL ORIFICE
  - 55.) FLOW CONTROL ORIFICE
  - 56.) FLOW CONTROL ORIFICE
  - 57.) FLOW CONTROL ORIFICE
  - 58.) FLOW CONTROL ORIFICE
  - 59.) FLOW CONTROL ORIFICE
  - 60.) FLOW CONTROL ORIFICE
  - 61.) FLOW CONTROL ORIFICE
  - 62.) FLOW CONTROL ORIFICE
  - 63.) FLOW CONTROL ORIFICE
  - 64.) FLOW CONTROL ORIFICE
  - 65.) FLOW CONTROL ORIFICE
  - 66.) FLOW CONTROL ORIFICE
  - 67.) FLOW CONTROL ORIFICE
  - 68.) FLOW CONTROL ORIFICE
  - 69.) FLOW CONTROL ORIFICE
  - 70.) FLOW CONTROL ORIFICE
  - 71.) FLOW CONTROL ORIFICE
  - 72.) FLOW CONTROL ORIFICE
  - 73.) FLOW CONTROL ORIFICE
  - 74.) FLOW CONTROL ORIFICE
  - 75.) FLOW CONTROL ORIFICE
  - 76.) FLOW CONTROL ORIFICE
  - 77.) FLOW CONTROL ORIFICE
  - 78.) FLOW CONTROL ORIFICE
  - 79.) FLOW CONTROL ORIFICE
  - 80.) FLOW CONTROL ORIFICE
  - 81.) FLOW CONTROL ORIFICE
  - 82.) FLOW CONTROL ORIFICE
  - 83.) FLOW CONTROL ORIFICE
  - 84.) FLOW CONTROL ORIFICE
  - 85.) FLOW CONTROL ORIFICE
  - 86.) FLOW CONTROL ORIFICE
  - 87.) FLOW CONTROL ORIFICE
  - 88.) FLOW CONTROL ORIFICE
  - 89.) FLOW CONTROL ORIFICE
  - 90.) FLOW CONTROL ORIFICE
  - 91.) FLOW CONTROL ORIFICE
  - 92.) FLOW CONTROL ORIFICE
  - 93.) FLOW CONTROL ORIFICE
  - 94.) FLOW CONTROL ORIFICE
  - 95.) FLOW CONTROL ORIFICE
  - 96.) FLOW CONTROL ORIFICE
  - 97.) FLOW CONTROL ORIFICE
  - 98.) FLOW CONTROL ORIFICE
  - 99.) FLOW CONTROL ORIFICE
  - 100.) FLOW CONTROL ORIFICE

DRAWING SUBJECT TO CHANGE WITHOUT NOTICE

Figure A.1: Flow Schematic

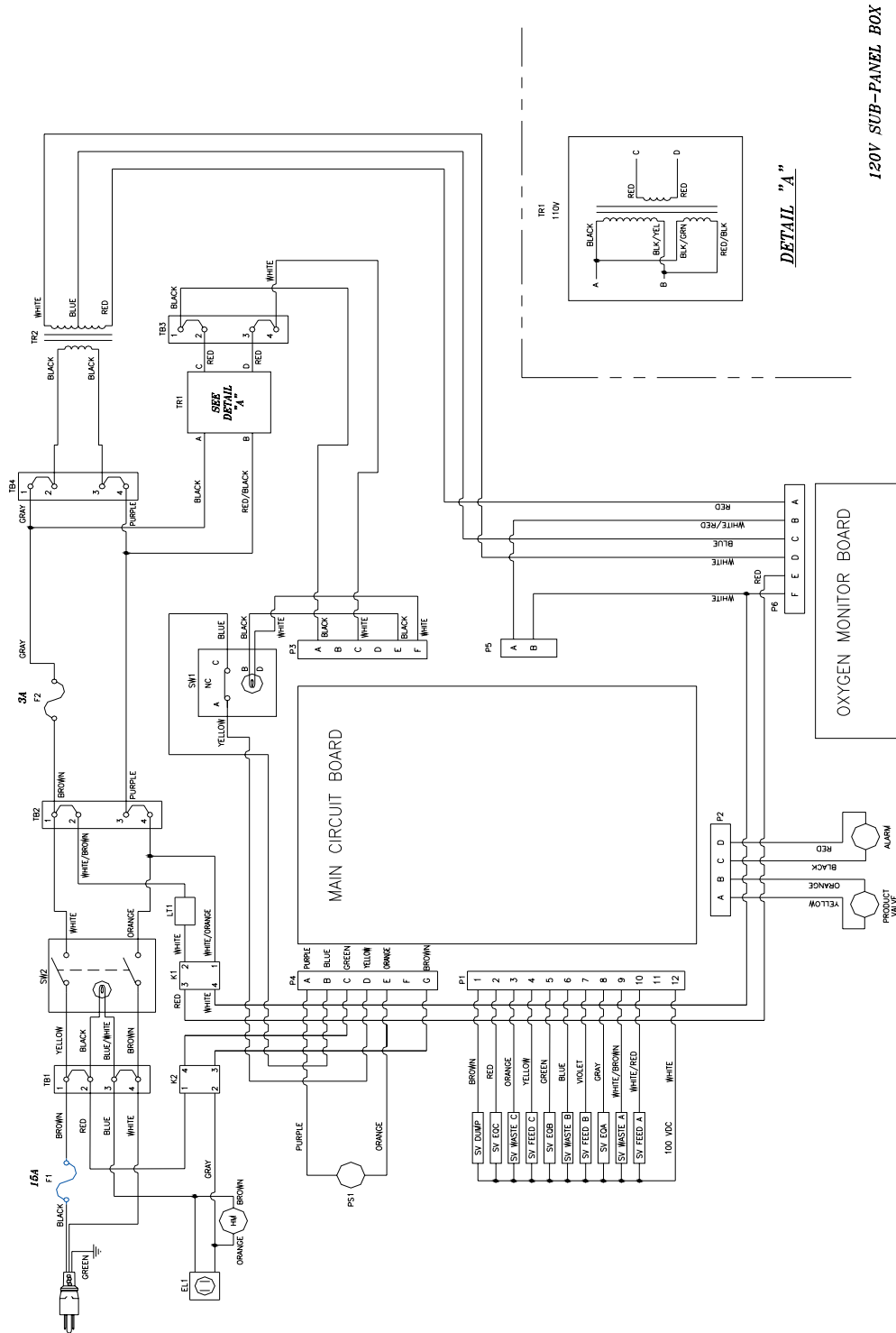

Figure A.2: Wiring Schematic (120 V, 60 Hz) – PSA Enclosure



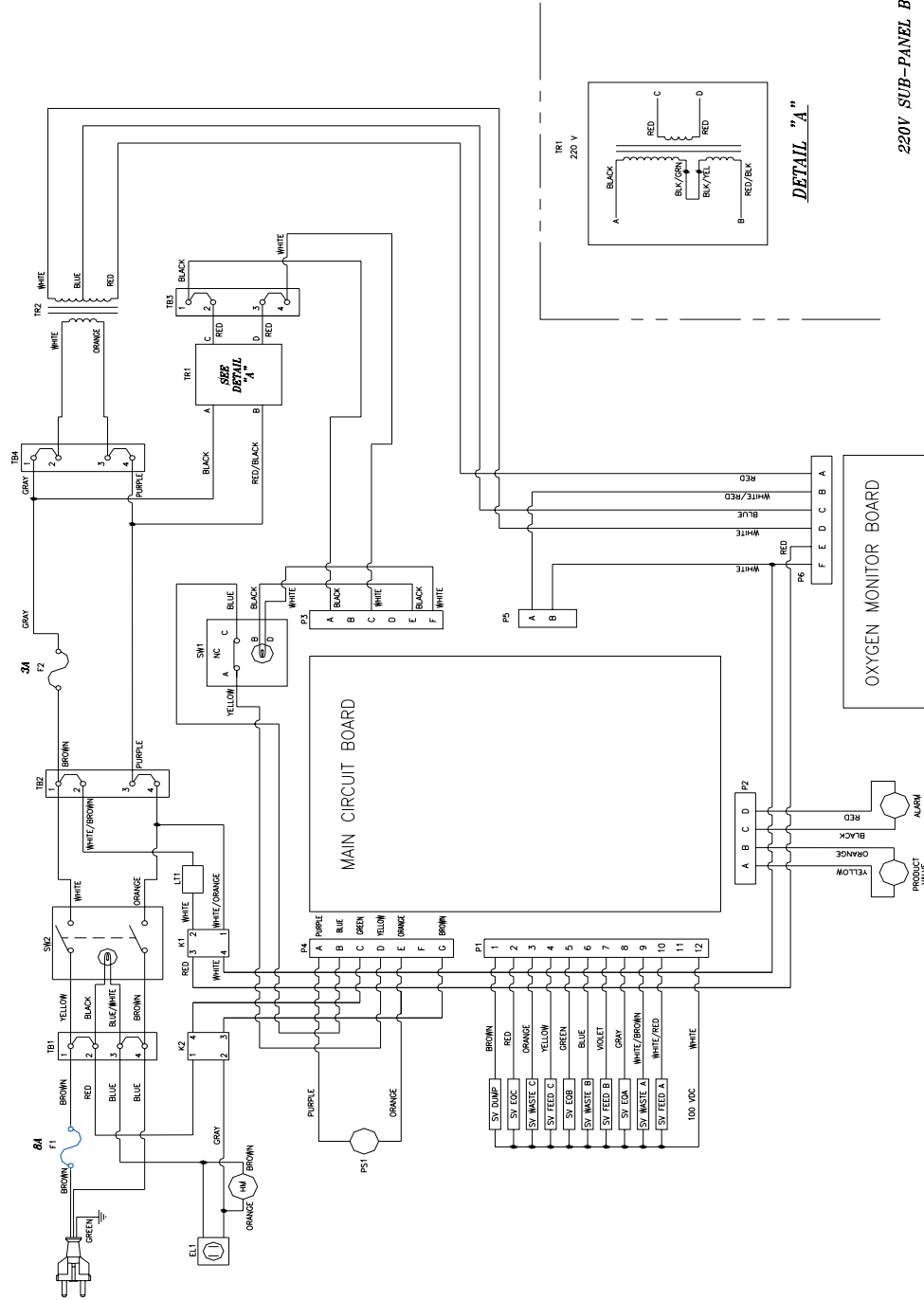

Figure A.3: Wiring Schematic (240 V, 50 Hz) – PSA Enclosure

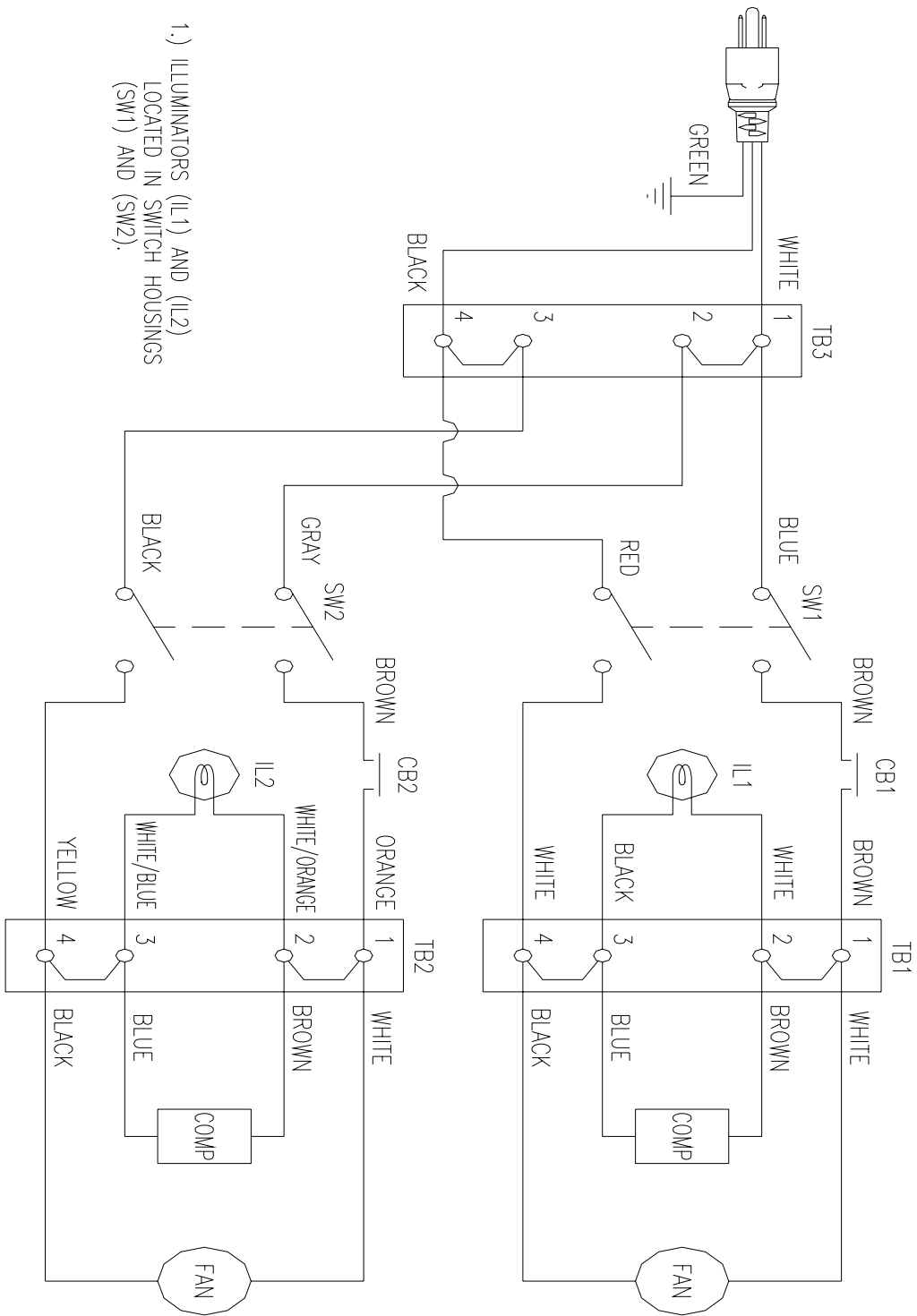

Figure A.4: Wiring Schematic (120 V, 60 Hz) – Compressor Enclosure

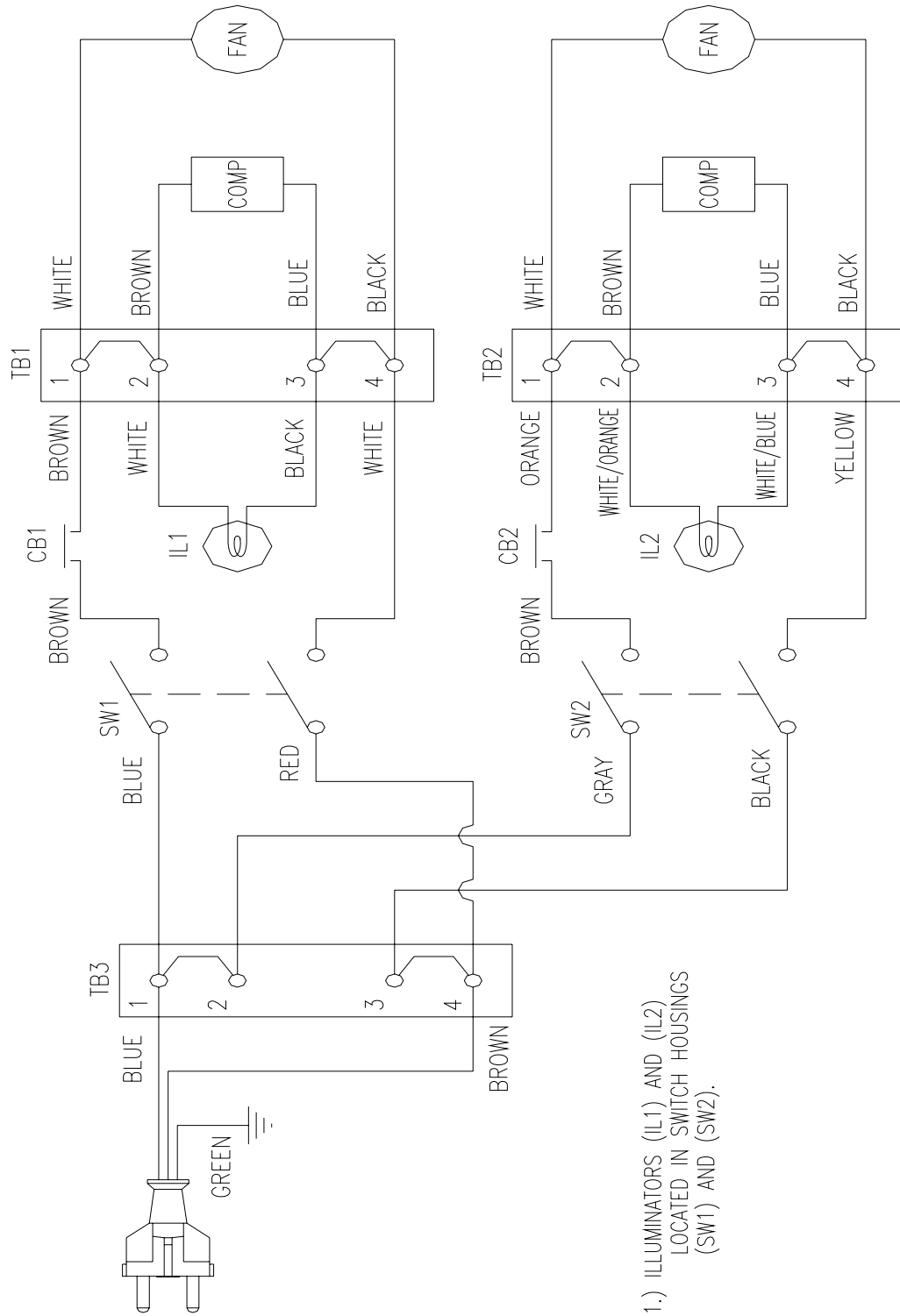

Figure A.5: Wiring Schematic (240 V, 50 Hz) – Compressor Enclosure



## **B Appendix**

## **Warranty>Returns**

### **Product Warranty**

AirSep Corporation (“AirSep”) warrants to the party purchasing from AirSep (the “original purchaser”) the PSA Oxygen Concentrator to be free from defect in parts and workmanship for one year from the date of start-up, not to exceed eighteen (18) months from the date of shipment to the original purchaser, under normal use, maintenance and operation\*. TO THE EXTENT PERMITTED UNDER APPLICABLE LAW, ALL WARRANTIES WITH RESPECT TO SUCH UNIT SHALL ONLY EXTEND TO AND BE FOR THE BENEFIT OF THE ORIGINAL PURCHASER AND SHALL NOT BE ASSIGNABLE TO, EXTEND TO OR BE FOR THE BENEFIT OF ANY OTHER PARTY. AirSep’s obligations under this warranty are limited, at AirSep’s option, to the repair, replacement or refunding the purchase price of any such unit of equipment (or part thereof) found by AirSep to be defective in parts or workmanship; provided, however, that AirSep shall have no obligation hereunder with respect to a defective part unless it receives written notice of such defect prior to the expiration of the applicable warranty period as referenced above.

Each unit of equipment for which a warranty claim is asserted shall, at the request of AirSep, be returned on a prepaid basis with proof of purchase date to the AirSep factory specified by AirSep at the expense of the original purchaser. Replacement parts shall be warranted as stated above for the unexpired portion of the original warranty. This warranty does not extend to any unit or part subjected to misuse (at AirSep’s sole determination), accident, improper maintenance or application, or which has been repaired or altered outside of the AirSep factory without the express prior written authorization of AirSep.

Notwithstanding anything to the contrary contained herein, during the applicable warranty period, as specified above, AirSep will pay the cost of return freight charges to the original purchaser, provided an authorized AirSep representative approved return of the unit or parts, for any equipment found by AirSep to be defective. For warranty repairs performed during the first 90 days from the date of invoice, AirSep will pay freight both ways. After the applicable parts warranty period has expired, the original purchaser is responsible for freight both ways.

---

\* Please refer to the appropriate product documentation for applicable installation and operating requirements.

## Limits of Liability

THE FOREGOING WARRANTY IS THE ONLY WARRANTY MADE BY AIRSEP WITH RESPECT TO THE EQUIPMENT (OR ANY PART THEREOF) AND IS IN LIEU OF ANY OTHER WARRANTY, EXPRESSED OR IMPLIED, IN FACT OR IN LAW, INCLUDING WITHOUT LIMITATION ANY WARRANTIES OF MERCHANTABILITY OR FITNESS FOR ANY PARTICULAR PURPOSE. IT IS EXPRESSLY UNDERSTOOD THAT THE SOLE AND EXCLUSIVE REMEDY FOR ANY DEFECT IN PARTS OR WORKMANSHIP IS LIMITED TO ENFORCEMENT OF AIRSEP'S OBLIGATIONS AS SET FORTH ABOVE, AND AIRSEP SHALL NOT BE LIABLE TO ORIGINAL PURCHASER OR ANY OTHER PARTY FOR LOSS OF USE OF THE EQUIPMENT, LOST PROFITS OR FOR ANY OTHER SPECIAL, INDIRECT, INCIDENTAL, OR CONSEQUENTIAL DAMAGES (EVEN IF AIRSEP HAS BEEN ADVISED OF THE POSSIBILITY OF SUCH DAMAGES).

## Returning the Oxygen Concentrator or a Component for Service

If the oxygen Concentrator or a defective part requires service, contact your distributor. If instructed by your distributor to contact AirSep Corporation, follow the procedure below to return the oxygen Concentrator or a component for service or credit.

- 1) Obtain a Return Goods Authorization (RGA) number from the AirSep Commercial Products Service Department. (Refer to Chapter 8, Troubleshooting for information about contacting AirSep Corporation.) Before you call for service assistance, have the following information readily available:
  - Oxygen Concentrator Model
  - Serial Number
  - Hours of Use
  - Invoice Date



**NOTE**

AirSep Corporation issues no credit for any warranted item until you present the model number, serial number, and invoice date of the oxygen Concentrator, and defective part is returned to AirSep Corporation.

- 2) Write the RGA number clearly on the outside of the shipping container.



AirSep Corporation accepts no item(s) for service or credit unless prior written authorization was issued by AirSep Corporation.

- 3) Return item(s) in their original packaging material. Pack merchandise for a safe return. AirSep Corporation assumes no responsibility for damage that occurs in transit. Any damage to the oxygen Concentrator or a component because of failure to follow this procedure is the sole responsibility of the customer.



Return item(s) on a freight prepaid basis only.





## **C Appendix**

## **Parts List**

Use the following lists to order parts for the oxygen concentrator. To order, please contact your distributor. If instructed by your distributor to contact AirSep Corporation, contact the AirSep Commercial Products Service Department as described in Chapter 8, Troubleshooting. If the list does not contain the part you require, please provide a precise description of the part when you call.



| <b>Model Centrox 120 VAC Spare Parts</b> |            |               |
|--|------------|---------------|
| <b>Item</b>                              | <b>Qty</b> | <b>Part #</b> |
| Filter, Element                          | 1          | FI153-1       |
| Foam, Filter, 1 7/8" dia                 | 1          | FO039-1       |
| Foam, Filter, 4"X4"                      | 1          | FO015-1       |
| Compressor, 115V/60                      | 1          | CO185-1       |
| Compressor Rebuild Kit                   | 2          | CO220-1       |
| Valve, Rebuild Kit, 316372               | 6          | VA034-1       |
| Valve, Rebuild Kit, 316375               | 3          | VA048-1       |
| Valve, Solenoid, 1/8" 100VDC             | 1          | VA495-1       |
| <b>Emergency Kit</b>                     |            |               |
| Check Valve, 1/4"                        | 1          | VA044-1       |
| Solenoid Valve, 3/8"                     | 1          | VA011-1       |
| Circuit Board, 110V                      | 1          | CB057-1       |
| Circuit Board, O2 Monitor                | 1          | CB005-5       |
| Circuit Breaker 10 amp                   | 1          | CR021-1       |
| Fan, 115V/50/60                          | 1          | FN001-3       |
| Fuse, 15 amp                             | 1          | FU009-1       |
| Fuse, 3 amp                              | 1          | FU004-1       |
| Gauge, 0-100 psi                         | 1          | GA001-2       |
| Heat Exchanger                           | 1          | HX010-2       |
| Muffler                                  | 1          | MU009-1       |
| Pressure Switch                          | 1          | SW003-3       |
| Regulator, 1/8"                          | 1          | RG022-1       |
| Relay, 45 amp                            | 1          | RL013-2       |
| Sieve Bed Assy.                          | 1          | BE126-1       |
| Spring, Compressor Mount                 | 4          | SP005-2       |
| Transformer, 115/10 VAC tap 60HZ         | 1          | TR001-1       |
| Transformer, 115/230VAC                  | 1          | TR027-1       |
| Flow Meter, 15 SLPM, 50 PSIG VERTICAL    | 1          | FM025-2       |
| Filter, Coalescing w/ Metal Bowl         | 1          | FI137-1       |
| <b>Supplemental Equipment</b>            |            |               |
| Oxygen Analyzer, MAXTEC, MAX O2 Plus     | 1          | AN005-1       |
| Oxygen Analyzer, MAXTEC, HANDHELD        | 1          | AN021-1       |
| <b>Regulator Pressure Test Kit</b>       | 1          | KI488-1       |

| <b>Model Centrox 240 VAC Spare Parts</b> |            |               |
|--|------------|---------------|
| <b>Item</b>                              | <b>Qty</b> | <b>Part #</b> |
| Filter, Element,MTP-95-547               | 1          | FI153-1       |
| Foam,Filter,1 7/8" dia                   | 1          | FO039-1       |
| Foam,Filter,4"X4"                        | 1          | FO015-1       |
| Compressor,240V/50                       | 1          | CO185-2       |
| Compressor Rebuild Kit                   | 1          | CO220-1       |
| Valve, Rebuild Kit,316372                | 6          | VA034-1       |
| Valve, Rebuild Kit,316375                | 3          | VA048-1       |
| Valve, Solenoid,1/8" 100VDC              | 1          | VA495-1       |
| <b>Emergency Kit</b>                     |            |               |
| Check Valve, 1/4"                        | 1          | VA044-1       |
| Solenoid Valve, 3/8"                     | 1          | VA011-1       |
| Circuit Board,240V                       | 1          | CB057-1       |
| Circuit Board,O2 Monitor                 | 1          | CB005-5       |
| Circuit Breaker 6 amp                    | 1          | CR022-1       |
| Fan,240VAC/50/60                         | 1          | FN001-4       |
| Fuse, 8 amp                              | 1          | FU012-1       |
| Fuse,3 amp                               | 1          | FU004-1       |
| Gauge,0-100 psi                          | 1          | GA001-2       |
| Heat Exchanger                           | 1          | HX010-2       |
| Muffler                                  | 1          | MU009-1       |
| Pressure Switch                          | 1          | SW003-3       |
| Regulator, 1/8"                          | 1          | RG022-1       |
| Relay, 45 amp                            | 1          | RL013-2       |
| Sieve Bed Assy.                          | 1          | BE126-1       |
| Spring, Compressor Mount                 | 4          | SP005-2       |
| Transformer, 115/10 VAC tap 60HZ         | 1          | TR001-1       |
| Transformer, 115/230VAC                  | 1          | TR027-1       |
| Flow Meter,15 SLPM,50 PSIG VERTICAL      | 1          | FM025-2       |
| Filter, Coalescing w/ Metal Bowl         | 1          | FI137-1       |
| <b>Supplemental Equipment</b>            |            |               |
| Oxygen Analyzer, MAXTEC, MAX O2 Plus     | 1          | AN005-1       |
| Oxygen Analyzer, MAXTEC, HANDHELD        | 1          | AN021-1       |
| <b>Regulator Pressure Test Kit</b>       | 1          | KI488-1       |

## **D Appendix Component Literature**

### **Filters**

- Wilkerson Corporation  
M03-02-M00  
1/4" FPT  
Mini, Compact, Standard, & Hi-Flow Oil  
Removal Filters  
[Installation and Maintenance Sheet](#)

### **Regulators**

- Norgren  
General Purpose Regulators  
[Installation Sheet](#)
- Siemens Energy & Automation  
Moore Constant Differential Type Flow Controllers  
[Installation, Operation and Maintenance Sheet](#)

### **Pressure Switch**

- ASCO Switch Co.  
PG-Series  
Tri-point pressure switches  
[Installation and Maintenance Instructions](#)

### **Valves**

- ASCO Valves  
Open-Frame Solenoids  
Series U8016 and US8016  
[Installation and Maintenance Instructions](#)
- ASCO Valves  
M6 Open-Frame Solenoids  
Drawing No. 214639-107  
[Installation and Maintenance Instructions](#)
- ASCO Valves  
Form No. V6950R5  
[Installation and Maintenance Instructions](#)



**Pneumatic Division**  
 Richland, Michigan 49083  
 269-629-5000

**Installation & Service Instructions:**  
**1C100H**  
**Mini, Compact, Standard, & Hi-Flow**  
**Oil Removal Filters**  
**ISSUED: November, 2003**  
**Supersedes: October, 2000**  
 Doc.# 1C100, ECN# 030539, Rev. 10

**⚠ WARNING**

To avoid unpredictable system behavior that can cause personal injury and property damage:

- Disconnect electrical supply (when necessary) before installation, servicing, or conversion.
- Disconnect air supply and depressurize all air lines connected to this product before installation, servicing, or conversion.
- Operate within the manufacturer's specified pressure, temperature, and other conditions listed in these instructions.
- Medium must be moisture-free if ambient temperature is below freezing.
- Service according to procedures listed in these instructions.
- Installation, service, and conversion of these products must be performed by knowledgeable personnel who understand how pneumatic products are to be applied.
- After installation, servicing, or conversion, air and electrical supplies (when necessary) should be connected and the product tested for proper function and leakage. If audible leakage is present, or the product does not operate properly, do not put into use.
- Warnings and specifications on the product should not be covered by paint, etc. If masking is not possible, contact your local representative for replacement labels.

**⚠ CAUTION**

Polycarbonate bowls, being transparent and tough, are ideal for use with Filters and Lubricators. They are suitable for use in normal industrial environments, but should not be located in areas where they could be subjected to direct sunlight, an impact blow, nor temperatures outside of the rated range. As with most plastics, some chemicals can cause damage. Polycarbonate bowls should not be exposed to chlorinated hydrocarbons, ketones, esters and certain alcohols. They should not be used in air systems where compressors are lubricated with fire-resistant fluids such as phosphate ester and diester types.

Metal bowls are recommended where ambient and/or media conditions are not compatible with polycarbonate bowls. Metal bowls resist the action of most such solvents, but should not be used where strong acids or bases are present or in salt laden atmospheres. Consult the factory for specific recommendations where these conditions exist.

**TO CLEAN POLYCARBONATE BOWLS USE MILD SOAP AND WATER ONLY! DO NOT** use cleansing agents such as acetone, benzene, carbon tetrachloride, gasoline, toluene, etc., which are damaging to this plastic.

Bowl guards are recommended for added protection of polycarbonate bowls where chemical attack may occasionally occur.

**Introduction**

Follow these instructions when installing, operating, or servicing the product.

**Application Limits**

These products are intended for use in general purpose compressed air systems only.

**With Polycarbonate Bowl**

|                                       | kPa                 | PSIG       | bar         |
|---------------------------------------|---------------------|------------|-------------|
| <b>Operating Pressure Maximum</b>     | <b>1000</b>         | <b>150</b> | <b>10.3</b> |
| <b>Operating Temperature Maximum:</b> | <b>52°C (125°F)</b> |            |             |

**With Metal Bowl**

|                                       | kPa                 | PSIG       | bar         |
|---------------------------------------|---------------------|------------|-------------|
| <b>Operating Pressure Maximum</b>     | <b>1700</b>         | <b>250</b> | <b>17.0</b> |
| <b>Operating Temperature Maximum:</b> | <b>80°C (175°F)</b> |            |             |

**With Automatic Drain**

|                                   | kPa       | PSIG      | bar         |
|-----------------------------------|-----------|-----------|-------------|
| <b>Operating Pressure Maximum</b> | <b>68</b> | <b>10</b> | <b>0.68</b> |

**Installation**

1. The equipment to which the filter is attached should be internally cleaned to remove all traces of accumulated oil and dirt. Also, new pipe or hose should be installed between the filter and equipment being protected.
2. Blow all upstream pipe work clear of accumulated dirt and liquids.
3. Select a filter location as close as possible to the equipment being protected and downstream of any pressure regulator.
4. A 5 micrometer pre-filter is recommended to protect the high efficiency filter and to prolong the element life.
5. Install filter so that air flows in the direction of arrow on cover.
6. Install filter vertically with the bowl drain mechanism at the bottom. Free moisture will thus drain into the sump "quiet-zone" at the bottom of the bowl (automatic drain models are recommended as standard equipment).

**Operation**

Manual drain filters must be drained regularly before the separated moisture and oil reaches the bottom of the filter element. Automatic drain models will collect and dump the liquids automatically.

Pressure differential gauges should be used to determine when the maximum recommended pressure differential of 10 PSI (0.7 KG/CM<sup>2</sup>) has been reached.

**DO NOT EXCEED THE RATED RECOMMENDED FLOWS. THE MINIMUM FLOW IS TEN PERCENT OF THE NOMINAL RATING.**

**⚠ WARNING**

**FAILURE OR IMPROPER SELECTION OR IMPROPER USE OF THE PRODUCTS AND/OR SYSTEMS DESCRIBED HEREIN OR RELATED ITEMS CAN CAUSE DEATH, PERSONAL INJURY AND PROPERTY DAMAGE.**

This document and other information from The Company, its subsidiaries and authorized distributors provide product and/or system options for further investigation by users having technical expertise. It is important that you analyze all aspects of your application, including consequences of any failure and review the information concerning the product or systems in the current product catalog. Due to the variety of operating conditions and applications for these products or systems, the user, through its own analysis and testing, is solely responsible for making the final selection of the products and systems and assuring that all performance, safety and warning requirements of the application are met.

The products described herein, including without limitation, product features, specifications, designs, availability and pricing, are subject to change by The Company and its subsidiaries at any time without notice.

**EXTRA COPIES OF THESE INSTRUCTIONS ARE AVAILABLE FOR INCLUSION IN EQUIPMENT / MAINTENANCE MANUALS THAT UTILIZE THESE PRODUCTS. CONTACT YOUR LOCAL REPRESENTATIVE.**

Mini, Compact, Standard & Hi-Flow Oil Removal Filter

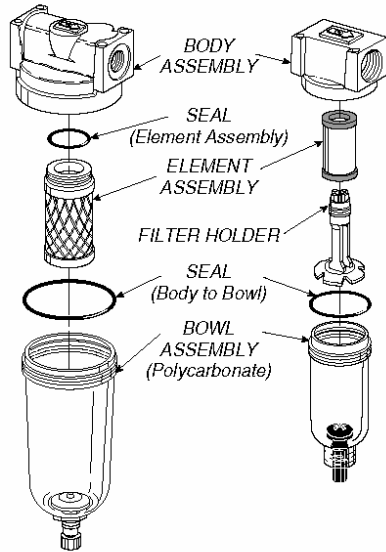

1C100H

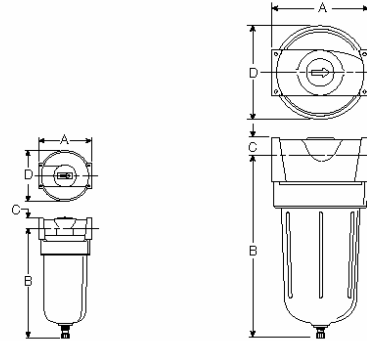

Mini, Compact & Standard

Hi-Flow

Dimensions

| Model    | Port Size          | A     | B     | B (with Auto Drain) | C    | D     |
|----------|--------------------|-------|-------|---------------------|------|-------|
| Mini     | 1/4"               | 1.69  | 3.82  | 3.87                | 39   | —     |
|          |                    | 43mm  | 97mm  | 98mm                | 10mm | —     |
| Compact  | 1/4"-3/8"          | 2.75  | 5.77  | 5.65                | 60   | 2.64  |
|          |                    | 70mm  | 147mm | 144mm               | 15mm | 67mm  |
| Standard | 3/8", 1/2"-3/4"    | 3.24  | 7.08  | 6.96                | 73   | 3.03  |
|          |                    | 82mm  | 180mm | 177mm               | 19mm | 77mm  |
| Hi-Flow  | 3/4"-1-1/4"-1-1/2" | 5.00  | 9.38  | 9.26                | 1.18 | 4.84  |
|          |                    | 127mm | 238mm | 235mm               | 30mm | 123mm |

Maintenance

To replace the element in the filter, first shut off the air supply and relieve pressure within the filter bowl. Unscrew the bowl and unscrew the filter element. This element cannot be cleaned and should be replaced when a pressure differential of 10 PSI (0.7 KG/CM<sup>2</sup>) is reached. To install a new filter element hold the element by the bottom end cap, position the new o-ring over the top threaded section and make sure it is screwed tightly into place.

**⚠ CAUTION: Touching or handling the element section may cause contamination, spotting or migration of oil.**

Automatic drains should be checked to insure they are operating correctly.

Troubleshooting

(If oil aerosol appears downstream from the filter):

1. Examine downstream air lines to determine if they were cleaned out before installation of the filter. Residual oil will contaminate an installation from new pipe work if it is not initially cleaned.
2. Determine if the sealing gasket or o-ring is in place, and that it is not cut or otherwise damaged. (When checking the element, do not touch the element's body. Always handle the element by the bottom end cap.) When reinstalling the element, turn it gently to make sure that it is screwed tightly in place.
3. Check the rate of air being used. The air flow should not exceed the rated capacity of the element, nor be less than 10% of its rated flow.
4. Check the inlet air temperature; this should not exceed 65°C (150°F). Where higher temperatures are used, oil vapor may condense if the air cools downstream of the filter.
5. Check for acid fumes or other harmful gases being drawn into the compressor intake. The element may be attacked by certain chemicals.
6. Determine the type of oil used in the compressor. Some synthetic or high flash point oils are detrimental — contact factory for advice.

Kits Available

| Description                                | Kit No. |
|--|---------|
| <b>Element Assemblies: (Includes Seal)</b> |         |
| 6 SCFM (Mini)                              | PS446   |
| 12 SCFM (Compact)                          | PS146   |
| 20 SCFM (Standard)                         | PS245   |
| 30 SCFM (Standard)                         | PS246   |
| 50 SCFM (Hi-Flow)                          | PS351B  |
| 100 SCFM (Hi-Flow)                         | PS350   |
| <b>Polycarbonate Bowl Kit</b>              |         |
| (1) Polycarbonate Bowl with Manual Drain   |         |
| (1) Seal (Body to Bowl)                    |         |
| Mini                                       | PS404   |
| Compact                                    | PS166   |
| Standard                                   | PS266   |
| Hi-Flow (Metal Bowl)                       | PS369   |

Accessories

| Description                                | Kit No. |         |          |         |
|--|---------|---------|----------|---------|
|  | Mini    | Compact | Standard | Hi-Flow |
| Automatic Drain (Includes Seal)            |         | PS506   | PS506    | PS506   |
| Bowl Guard Kit                             |         | PS107   | PS207    | N/A     |
| Mounting Bracket Kit*                      |         | PS109   | PS209    | PS309   |
| Metal Bowl w/Sight Glass (Manual Drain)    |         | PS169   | PS269    | PS369   |
| Polycarbonate Bowl (Automatic Drain)       | PS408   | PS143   | PS243    | N/A     |
| Metal Bowl w/Sight Glass (Automatic Drain) |         | PS144   | PS244    | PS344C  |
| Metal Bowl (Manual Drain)                  | PS447B  |         |          |         |
| Metal Bowl (Automatic Drain)               | PS451   |         |          |         |

\* Not supplied with units, must be ordered separately.





**NORGREN**

**R01, R04, R06\*, R07, R08, R11, R14, R15, R16\*, R17, R18, R43\*, R46, R64, R68, R72, R73, R74, R91\*, 11-002, 11-009\*, 11-044\*, 11-111, 20AG**

**UI-200**

9/00  
Supersedes 12/97

**GENERAL PURPOSE REGULATORS (ENGLISH)**

Contact your Norgren supplier for complete instructions and kits.

**Installation** - Shut off air pressure. Install in air line:

- with air flow in direction of arrow on body. In some cases **IN** may be stamped next to the inlet port.
- upstream of lubricators, and cycling valves. Reverse flow regulators can be installed upstream or downstream of cycling valves.
- as close as possible to the device being served.
- at any angle.

**Adjustment** - Turn adjustment clockwise to increase and counterclockwise to decrease outlet pressure setting. To reduce pressure, first reduce to a pressure less than that desired, then increase to the desired outlet pressure.

**Warning**

These products are intended for use in industrial compressed air systems only. Do not use these products where pressures and temperatures can exceed those listed on the product label.

If outlet pressure in excess of the regulator pressure setting could cause downstream equipment to rupture or malfunction, install a pressure relief device downstream of the regulator. The relief pressure and flow capacity of the relief device must satisfy system requirements.

Before using with fluids other than air, for nonindustrial applications, or for life support systems, consult Norgren.

\* Non-relieving models with brass or plastic body may be used in water service.

**REGOLATORI PER IMPIEGHI GENERICI (ITALIAN)**

Contattare il Vostro fornitore Norgren per istruzioni complete e ricambi.

**Installazione** - Togliere la pressione dell'aria. Posizione sulla linea:

- Con il flusso aria in direzione della freccia riportata sul corpo. In alcuni casi si potrebbe trovare la parola **IN** stampata vicino alla connessione in entrata.
- A monte dei lubrificatori e delle valvole di controllo. I regolatori con flusso contrario possono essere installati sia a valle che a monte delle valvole di controllo.
- Il più vicino possibile all'apparecchio che deve essere alimentato.
- In qualsiasi posizione.

**Regolazione** - Girare il dispositivo di regolazione in senso orario per aumentare e in senso antiorario per diminuire la pressione di taratura. Per ridurre la pressione, prima di tutto portare la pressione al di sotto del valore desiderato, poi aumentarla fino al valore richiesto.

**Avvertenza**

Questi prodotti sono adatti esclusivamente all'impiego su sistemi industriali ad aria compressa. Non impiegare in presenza di pressioni e temperature superiori a quelle riportate sulla targhetta.

Se un aumento della pressione in uscita rispetto al valore di taratura dovesse causare rotture o malfunzionamento nell'impianto a valle, installare una valvola limitatrice di pressione a valle del regolatore. La pressione e la capacità di scarico della valvola limitatrice devono soddisfare i requisiti di sicurezza del sistema.

Prima dell'impiego con altri fluidi che non siano aria, per applicazioni non industriali, o in apparecchiature medicali consultare la Norgren.

\* Modelli senza scarico di sovrappressione, con corpo in ottone o in plastica, possono essere impiegati per acqua.

**REGULADORES PARA APLICACIONES GENERALES (PORTUGUESE)**

Consulte seu fornecedor Norgren para instruções completas e kits de reparo.

**Instalação** - Desligue a pressão de ar. Instale na linha de ar:

- Com o fluxo de ar na direção da seta do corpo. Em alguns casos **IN** pode estar gravado próximo ao orifício de entrada.
- Antes dos lubrificadores e válvulas de controle direcional. Os reguladores de fluxo bi-direcionais podem ser instalados antes ou depois das válvulas de controle direcional.
- Tão próximo quanto possível do dispositivo que está sendo atendido.
- Em qualquer ângulo.

**Regulagem** - Gire no sentido horário para aumentar e no sentido anti-horário para diminuir a pressão de saída desejada. Para reduzir a pressão, primeiro reduza-a para um valor menor do que desejado e posteriormente aumente até a pressão final.

**Advertências**

Estes produtos devem ser usados somente em sistemas de ar comprimido industrial. Não os use onde pressões e temperaturas excederem aqueles listados nas etiquetas dos produtos.

Se a pressão de saída for superior à estabelecida podendo causar danos ao equipamento, instale um dispositivo de alívio de pressão após o regulador, que atenda aos requisitos do sistema. Antes de usar outros fluidos para aplicações não industriais ou para sistemas de suporte à saúde, consulte a Norgren.

\* Modelos sem alívio, com corpo de latão ou plástico podem ser usados em sistemas de água.

**REGULADORES DE USO GENERAL (SPANISH)**

Contacte con su proveedor Norgren para instrucciones completas y kits.

**Instalación** - Cerrar la presión de aire. Instalar en la línea del aire

- el caudal de aire deberá seguir la dirección de la marca en el cuerpo, en algunos casos la palabra **IN** puede estar impresa al lado de la conexión de entrada
- situarlo antes de los lubricadores y las válvulas de ciclo. Los reguladores de caudal reversible pueden instalarse antes o después de las válvulas de ciclo.
- lo más cerca posible del aparato al que está conectado
- en cualquier ángulo

**Regulación** - Girar el pomo de regulación en el sentido de las agujas del reloj para aumentar el nivel de presión de salida y en sentido contrario para reducirla. Para disminuir la presión, reducir en primer lugar a un nivel inferior al requerido; después aumentar hasta la presión de salida deseada.

**Advertencia**

Estos productos se han diseñado para su uso exclusivamente en sistemas industriales de aire comprimido. No usar estos productos en instalaciones en las que las presiones y temperaturas puedan superar las que figuran en la etiqueta del producto.

Si la presión de salida es superior al nivel de presión del regulador, podrían producirse roturas o fallos en los equipos situados después del mismo. En este caso, instalar un aparato con escape de presión después del regulador. La capacidad en cuanto a presión de escape y caudal del mecanismo de descarga deberá satisfacer las necesidades del sistema. Consultar con Norgren antes de utilizar estos productos con fluidos que no sean el aire, en aplicaciones no industriales o en sistemas de seguridad.

\* Modelos sin escape, con cuerpo de bronce o de plástico, pueden ser utilizados en sistemas de agua.

**汎用レギュレータ (JAPANESE)**

詳細及びキットに関しては供給元にお問い合わせ下さい。

**取付方法:**

- 空気圧力を閉じます。
- 本体上の矢印に気流方向を合わせます。入口のポートのとなりにはINと記されている場合があります。
- バルブカート、バルブの二次側に取付。逆流レギュレータはバルブの一次側、二次側どちら側でも取付可能。
- 保護する機器に出来るだけ近い位置に取付けます。
- どの角度でも取付けられます。

**調整:**

圧力設定を上げるには調整ノブを時計方向に、圧力設定を下げるには反時計方向に回します。高い設定値から低い設定値に変更する場合は、目的の圧力よりも低く下げた後、目的の圧力値まで上げるようにして下さい。

**注意事項:**

当該製品は工業用圧縮空気システムのみ使用できるように作られています。製品ラベル記載以外の温度、圧力では使用出来ません。

出力圧力がレギュレータの設定圧力を超え、レギュレータの二次側にある機器が壊れたり、作動不良が生じる恐れがある場合は、レギュレータの二次側にリリーフバルブを取付けて下さい。減圧装置の減圧および流量はシステムの要求値に合わせなければなりません。

空気以外の媒体や工業用以外の用途、又は生命維持システムに当該製品を使用する場合は、ノルグレン社までお問い合わせ下さい。

\* ノンリリーフタイプの真ちゅうまたはプラスチックボディではウォーターで取付可能な場合があります。

**通用减压阀 (CHINESE)**

需维修配件和全部使用说明, 请与诺冠供应商联系。

**安装:**

- 先关闭气路, 然后安装减压阀于气路。
- 气体流向与机体上的箭头指向一致, 有时入口端有IN标记。
- 置减压阀于油雾器和循环阀之前, 反向流减压阀置于循环阀之前或之后。
- 尽量接近所服务的设备。
- 安装角度不限。

**调节** - 顺时针转动以增大压力, 逆时针转动以降低压力。降低压力时, 先将压力降至所需压力之下, 然后调高压至所需压力。

**警告** - 本产品仅限于工业压缩空气系统, 请勿在超出产品标牌所示的压力和温度范围之外使用。如果输出压力超过设定压力会导致减压阀下游的设备失灵或爆裂, 则应在减压阀下游安装安全阀。安全阀的溢流压力和流量必须满足系统的要求。

欲将本产品用于空气以外的流体, 非工业用途或医疗设备, 请先与诺冠接洽。

- 在水压情况下, 可以使用铜或塑料的非弹性减压阀。



Siemens  
Energy & Automation

INSTRUCTIONS FOR INSTALLATION, OPERATION,  
AND MAINTENANCE OF MOORE CONSTANT  
DIFFERENTIAL TYPE FLOW CONTROLLERS

**WARNING:** Read instructions before  
installing to prevent personal injury  
or damage to equipment.

**SD63UL**  
Issue: 7  
Date: 9/91

**GENERAL INFORMATION**

The Moore Constant Differential Type Flow Controller is used in conjunction with an external needle valve to provide constant volume flow rates for either liquids or gases over a continuously adjustable flow range.

When used on gases, upstream pressure must be constant to provide a constant mass flow rate (i.e., standard volume units per time unit; e.g., SCFM). Constant upstream pressure is not needed for constant volume flow rates (i.e., volume units per time unit; e.g., CFM).

With liquids, both mass and volumetric flow rates are held constant, regardless of up or downstream pressures.

**MODEL DESIGNATION**

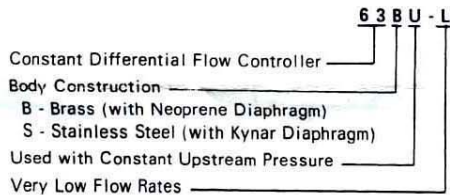

**SPECIFICATIONS**

Supply Pressure:

Minimum: At least 5 psi greater than the maximum downstream pressure of the needle valve-controller combination:

| MODEL | NEEDLE VALVE |          |
|-------|--------------|----------|
|       | CLOSED       | OPEN     |
| 63BU  | 50 psig      | 250 psig |
| 63BUL | 50 psig      | 250 psig |
| 63SU  | 100 psig     | 500 psig |
| 63SUL | 50 psig      | 500 psig |

Ambient Temperature Limits:

Models 63BU & BUL -40°F to +180°F  
Models 63SU & SUL -40°F to +250°F

**PRINCIPLE OF OPERATION**

If the pressure drop across a restriction is held constant, the flow through the restriction is constant. The needle valve (a variable restriction) can be set to an opening which will produce the desired flow rate.

The pressure drop ( $\Delta P$ ) across the needle valve is held constant by the flow controller as follows:

1. The input pressure ( $P_1$ ) is applied to the needle valve and to the top of the controller's diaphragm, and forces the diaphragm and attached plunger down.
2. The Differential Spring and downstream pressure ( $P_2$ ) force the diaphragm and plunger up. The Differential Spring produces an upward force equal to that produced by a constant pressure ( $K$ ).
3. The Controller is balanced when the force due to  $P_1$  equals the forces due to  $P_2$  and  $K$  (i.e.,  $P_1 = P_2 + K$ ). Since the pressure drop ( $\Delta P$ ) across the needle valve equals  $P_1 - P_2$ , and since  $P_1 - P_2$  equals  $K$ , then the pressure drop ( $\Delta P$ ) must equal  $K$ ; therefore flow is constant.

**SCHEMATIC**

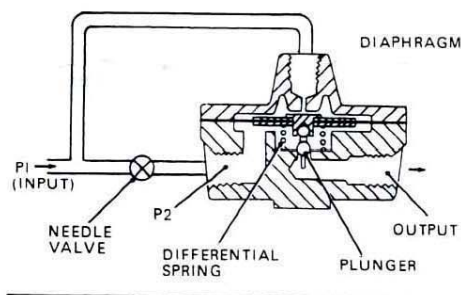

**INSTALLATION**

Mounting dimensions and the location and size of connections are shown on the installation drawings. The controller may be mounted in any desired position. The needle valve and feedback connections should be installed as close to the controller as possible to minimize pressure drop between these points. The supply to the controller should be filtered to remove any solids.

**Caution**

When installing the constant up stream flow controller, be sure the external needle valve is open. (See Installation Dwg.). Failure to do this could result in applying a differential pressure across the diaphragm of the flow controller in excess of its rated limit, thus causing the diaphragm to rupture.

**CAPACITY**

The formulas for the calculation of maximum and minimum flow rates can be found in Table 1.

The minimum controllable flow will depend on the leakage past the valve plunger in the controller. It is, there-

fore, a function of the cleanliness of the valve and the pressure drop across it as well as any inherent leakage. In general, for a standard flow controller, the minimum controllable flow will be approximately 1/100 of the maximum flow.

**TABLE 1 Flow Capacity Formulas**

|   | Higher Range<br>Models 63BD and 63SD;<br>63BU and 63SU                       | Low Flow<br>Models 63BD-L and 63SD-L;<br>63BU-L and 63SU-L             |
|---|--|--|
| <b>GAS FLOW-CAPACITY</b>                                  |  |  |
| Maximum at less than critical flow*                       | $SCCM = 4000 \sqrt{\frac{\Delta P}{SG}} \times Pd \times \frac{530}{T}$      | $SCCM = 400 \sqrt{\frac{\Delta P}{SG}} \times Pd \times \frac{530}{T}$ |
| Maximum at critical flow*                                 | $SCCM = 2000 Pu \sqrt{\frac{1}{SG} \times \frac{530}{T}}$                    | $SCCM = 200 Pu \sqrt{\frac{1}{SG} \times \frac{530}{T}}$               |
| Minimum controllable flow                                 | Approximately 1/200 of maximum   | $SCCM = 8 \frac{\Delta P (Pu + Pd)}{Rv T}$                             |
| <b>LIQUID FLOW-CAPACITY</b>                               |  |  |
| Maximum   | $CCM = 470 \sqrt{\frac{\Delta P}{SG}}$                                       | $CCM = 47 \sqrt{\frac{\Delta P}{SG}}$                                  |
| Minimum   | Approximately 1/200 of maximum   | $CCM = .06 \frac{\Delta P}{Rv}$  |
| <b>NEEDLE VALVE SIZING (With 3 psi drop across valve)</b> |  |  |
| For any liquid  | $Kn = \frac{CCM}{6550 \sqrt{\frac{1}{SG}}}$                                  |  |
| For any gas   | $Kn = \frac{SCCM}{49000 \sqrt{\frac{1}{SG} \times Pn \times \frac{530}{T}}}$ |  |

\*Critical flow exists when the ratio of upstream pressure (Pu) to downstream pressure (Pd) is equal to or less than approximately 0.53:

$$\left(\frac{Pd}{Pu} \leq 0.53\right)$$

The actual ratio value for air is 0.528; it should be noted that it varies slightly for other gases.

SCCM = Cubic centimeters per minute of gas at standard conditions (70° F, 14.7 psia). Note: 1 SCF = 28,317 SCC.

ΔP = psi pressure drop across the controller valve = total drop minus 3 psi.

Pu = psia pressure at inlet of controller (allow 3 psi for drop across the needle valve, if it is installed upstream).

Pd = psia pressure at outlet of controller (allow 3 psi for drop across the needle valve, if it is installed downstream).

Pn = psia pressure at outlet of needle valve.

SG = Specific gravity of the gas referred to air, or specific gravity of the liquid referred to water at 4° C.

T = Absolute temperature of the gas = degrees F + 460.

Rv = Ratio of viscosities of gas referred to air; or Ratio of viscosities of liquid at operating temperature to water at 4° C.

Kn = Flow constant of needle valve.

Rangeability and minimum controllable flow of each size depend upon the needle valve used, the specific gravity of the fluid, the operating pressures, and other factors.

The formulas permit calculation of maximum flows for both the low-flow and higher-range models. Because minimum flows occur in a laminar pattern with the low-flow models, a separate formula is furnished. Rangeability is considerably higher on gases than on liquids.

**FLOW-RANGE EXAMPLES**

**Conditions:**

- 15 psig (29.7 psia) at inlet of controller
- 10 psi drop across controller (not including 3 psi needle-valve drop)
- 70° F process temperature

|                                       | Max. Flow      | Min. Flow   |
|---------------------------------------|----------------|-------------|
| <b>Higher-range units (Series 63)</b> |                |             |
| On air                                | 56,000 scc/min | 280 scc/min |
| On water                              | 1,500 cc/min   | 7.5 cc/min  |
| <b>Low-range units (Series 63L)</b>   |                |             |
| On air                                | 5,600 scc/min  | 7 scc/min   |
| On water                              | 149 cc/min     | 0.6 cc/min  |



**OPERATION**

With the supply turned on, adjust the needle valve to obtain the desired flow rate. The valve may be adjusted for any flow within the capacity of the unit.

**MAINTENANCE**

The only maintenance normally required will be to keep the valve plunger and external needle valve clean. Any

change in the rate of flow for a given needle valve setting will probably be caused by partial clogging of the needle valve.

Failure to obtain minimum flows will probably be caused by solids on the controller valve plunger. It will be necessary to disassemble the 63-U model controller in order to remove the plunger valve. Use the Parts List for the controller as an assembling aid.

| MODEL | DIM. A | DIM. B |
|-------|--------|--------|
| 63BU  | 2 1/8  | 3 1/4  |
| 63BUL | 2 1/8  | 3 1/4  |
| 63BU  | 2 3/8  | 3 1/2  |
| 63BUL | 2 3/8  | 3 1/2  |

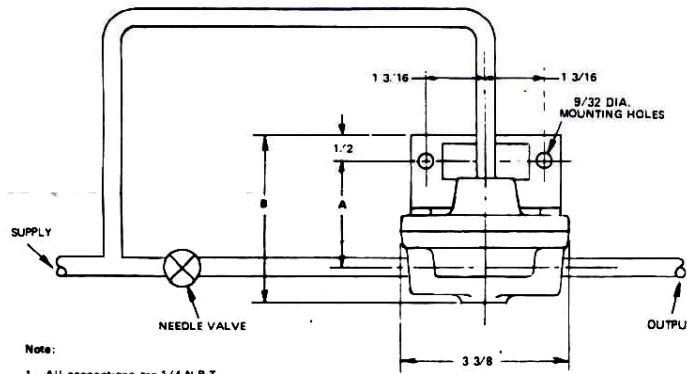
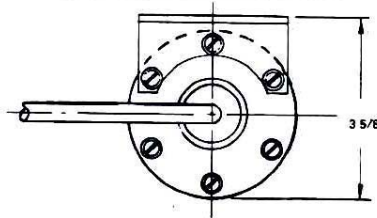

- Note:
1. All connections are 1/4 N.P.T.
  2. Unless otherwise specified, needle valve and all piping supplied by customer.

Installation Dwg. Model 63U Constant Flow Controller

## PARTS LIST

Siemens  
Energy & AutomationMOORE CONSTANT DIFFERENTIAL TYPE FLOW CONTROLLER  
FOR SMALL FLOWS — MODEL 63BU-L

Drawing No. 10746PL

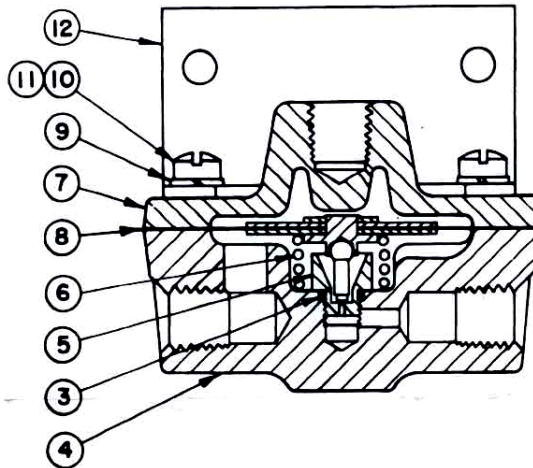
MODEL 63BU-L  
B/M 10746S6

| Item No. | Part No. | Description                  | Req'd |
|----------|----------|------------------------------|-------|
| 3        | 2938-1   | "O" Ring                     | 1     |
| 4        | 10746-10 | Bottom Forging               | 1     |
| * 5      | 10917-24 | Valve Seat                   | 1     |
| * 6      | 1518-5   | Differential Spring          | 1     |
| 7        | 2881-9   | Top Forging                  | 1     |
| * 8      | 10746-2  | Diaphragm and Valve Assembly | 1     |
| 9        |          | 1/4" Lockwasher              | 6     |
| 10       | Screw    | 1/4-20 x 3/4" Lg. Fil. Hd.   | 3     |
| 11       | Screw    | 1/4-20 x 5/8" Lg. Fil. Hd.   | 3     |
| 12       | 1145-19  | Mounting Bracket             | 1     |

\* Recommended On-Hand Spare Parts. Always Specify Range, Serial No. or Other Nameplate Information When Ordering Spare Parts

**PARTS LIST**

**Siemens  
Energy & Automation**

**MOORE CONSTANT DIFFERENTIAL TYPE FLOW CONTROLLER  
FOR SMALL FLOWS — MODEL 63SU-L**

Drawing No. 12046PL

**MODEL 63SU-L  
B/M 12046S11**

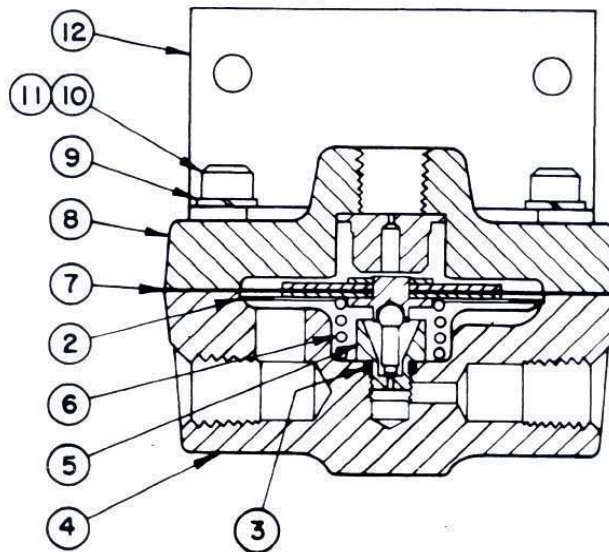

| Item No. | Part No. | Description                  | Req'd |
|----------|----------|------------------------------|-------|
| 2        | 12041-23 | Protecting Ring              | 1     |
| 3        | 2938-120 | "O" Ring                     | 1     |
| 4        | 12046-16 | Bottom Forging               | 1     |
| * 5      | 12046-8  | Valve Seat                   | 1     |
| * 6      | 3131-22  | Differential Spring          | 1     |
| * 7      | 12046-9  | Diaphragm and Valve Assembly | 1     |
| 8        | 12041-42 | Top Housing Assembly         | 1     |
| 9        |          | 1/4" Lockwasher              | 6     |
| 10       | Screw    | 1/4-20 x 1-1/4" Lg. Soc. Hd. | 3     |
| 11       | Screw    | 1/4-20 x 1" Lg. Soc. Hd.     | 3     |
| 12       | 1145-19  | Mounting Bracket             | 1     |

\* Recommended On-Hand Spare Parts. Always Specify Range, Serial No. or Other Nameplate Information When Ordering Spare Parts.

## PARTS LIST

Siemens  
Energy & AutomationMOORE CONSTANT DIFFERENTIAL TYPE FLOW CONTROLLER  
(CONSTANT UPSTREAM PRESSURE)

Drawing No. 12041PL

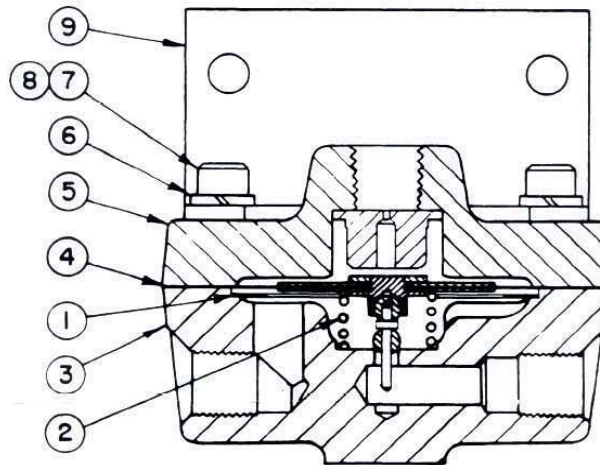
MODEL 63SU  
B/M 12041510

| Item No. | Part No.   | Description                                     | Req'd |
|----------|------------|---|-------|
| 1        | 12041-23   | Diaphragm Protecting Ring                       | 1     |
| *2       | 3131-22    | Differential Spring                             | 1     |
| 3        | 12041-41   | Bottom Forging                                  | 1     |
| *4       | 12041-33   | Valve and Diaphragm Assy.                       | 1     |
| 5        | 12041-42   | Top Housing Assy.                               | 1     |
| 6        | Lockwasher | 1/4", Steel, W.N.P.                             | 6     |
| 7        | Screw      | 1/4-20 x 1-1/4 Lg. Socket Hd.,<br>Steel, W.N.P. | 3     |
| 8        | Screw      | 1/4-20 x 1 Lg. Socket Hd.,<br>Steel, W.N.P.     | 3     |
| 9        | 1145-19    | Mounting Bracket                                | 1     |

\* Recommended On-Hand Spare Parts. Always Specify Range, Serial No., or Other Nameplate Information When Ordering Spare Parts.



**PARTS LIST**

**Siemens  
Energy & Automation**

**MOORE CONSTANT DIFFERENTIAL TYPE FLOW CONTROLLER  
(CONSTANT UPSTREAM PRESSURE)**

**Drawing No. 2882PL**

**MODEL 63BU  
B/M 2882S9**

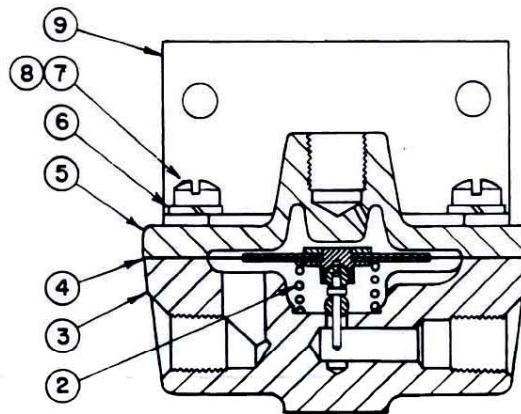

| Item No. | Part No.   | Description                                | Req'd |
|----------|------------|--|-------|
| *2       | 1518-5     | Differential Spring                        | 1     |
| 3        | 2882-18    | Bottom Forging                             | 1     |
| *4       | 2882-8     | Valve and Diaphragm Assy.                  | 1     |
| 5        | 2881-9     | Top Forging                                | 1     |
| 6        | Lockwasher | 1/4" Neverslip, Steel, W.N.P.              | 6     |
| 7        | Screw      | 1/4-20 x 3/4 Lg. Fil. Hd.<br>Steel, W.N.P. | 3     |
| 8        | Screw      | 1/4-20 x 5/8 Lg. Fil. Hd.<br>Steel, W.N.P. | 3     |
| 9        | 1145-19    | Mounting Bracket                           | 1     |

\* Recommended On-Hand Spare Parts. Always Specify Range, Serial No. or Other Nameplate Information When Ordering Spare Parts



# Installation & Maintenance Instructions

**ASCO® TRIPOINT® SWITCH UNITS**  
**LIMITED ADJUSTABLE DEADBAND SWITCH UNITS**

**PG—SERIES**

**OPEN—FRAME TYPE, GENERAL PURPOSE OR EXPLOSIONPROOF SWITCH ENCLOSURE**

**Form No. P7089R1**

## DESCRIPTION

The PG—Series Limited Adjustable Deadband Switch Units are used with transducer units to make Tripoint Pressure Switches or Temperature Switches. These switch units are made of aluminum alloy and designed for rugged use. The switch units may be provided as open—frame type construction or with a general purpose or watertight enclosure. All wiring terminals, adjustments, and visual scales are accessible from the front of the switch.

The switch may be supplied as a complete unit, with the switch assembly unit and transducer unit completely assembled. The components may be separate units to be assembled upon installation. The switch has an adjustable set point (set point increasing) and an adjustable deadband which controls (within limits) the reset point (set point decreasing). The switch unit can be mated with a wide selection of pressure or temperature transducers to cover a broad range of pressures, fluids, or temperatures. The switch will control electrical circuits in response to changes in pressure or temperature signals.

**IMPORTANT: These instructions cover the installation and use of this switch on pressure and temperature transducers. Select the paragraphs that apply to your particular installation and application. The word *signal* is used in place of pressure, or temperature changes.**

## INSTALLATION

Check the nameplate for the correct catalog number, pressure range, temperature range, media, and proof pressure or rated overrange temperature. Never apply incompatible fluids or exceed the pressure or temperature rating of the switch. Installation and inspection to be performed by qualified personnel.

Nameplates are located on switch (or switch cover) and on the bottom of the transducer. Check to be sure the third digit in each number is the same. If not, the unit should not be used (Refer to Figure 6).

**IMPORTANT: All internal adjustments have been made at the factory. Any adjustment, alteration or repair to the internal parts of the switch other than stated herein voids all warranties. Signal setting adjustments required are made by an adjusting nut on top of the switch (for set point) and a front knob adjustment (for deadband).**

## Temperature Limitations

Switch ambient temperature limits are -4°F (-20°C) to 122°F (50°C). To determine fluid temperature limitations, see Form No.P7090 for pressure transducer catalog numbers and construction materials, then refer to chart below.

| TRANSDUCER CONSTRUCTION MATERIALS | RATINGS FLUID TEMPERATURE      |
|-----------------------------------|--------------------------------|
| Buna N or Neoprene                | -4°F (-20°C) to 180°F (82°C)   |
| VITON®                            | -4°F (-20°C) to 250°F (121°C)  |
| 316 Stainless Steel               | -50°F (-45°C) to 300°F (149°C) |
| All Nylon                         | Maximum 180°F (82°C)           |
| All Nylon For Water Service       | Maximum 130°F (55°C)           |

For steam service, the fluid temperature with a pigtail (siphon tube or condensate loop) installed directly into the transducer will be below 180°F (82°C).

**Assembly Of Switch And Transducer Units** (Refer to Figure 6)

**IMPORTANT: The switch unit and transducer unit may be purchased as a complete assembly or as separate units. If separate units are purchased, refer to Form No. P7090 for a complete listing of switch unit and transducer unit combinations. Form No. P7090 is provided to ensure that the proper switch unit is assembled to the proper transducer unit.**

Pay careful attention to exploded view provided in Figure 6 for assembly of switch unit and transducer unit. Proceed in the following manner:

**CAUTION: The third digit in the catalog number on both the switch unit and the transducer unit must be identical. If not, do not assemble to each other. If the same, proceed.**

1. Remove bolts (4) from base of switch unit. On general purpose or watertight constructions, remove switch cover.
2. Remove instruction label and pressure or temperature switch range scale from the transducer unit.
3. Place transducer unit on base of switch unit and assemble. Start bolts (4) approximately two turns by hand to avoid the possibility of cross threading. After initial engagement, torque bolts (4) in a crisscross manner to 80±10 in—lbs [9,0± 1,1 Nm].
4. Remove backing paper from range scale and install on the front of the switch body over the opening for the adjusting indicator point.

## Positioning

Switch may be mounted in any position.

## Mounting

Refer to Figures 1, 2, and 3 for mounting.

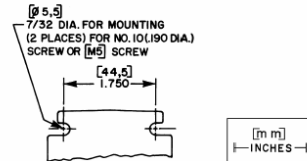

Figure 1. Open—Frame Mounting

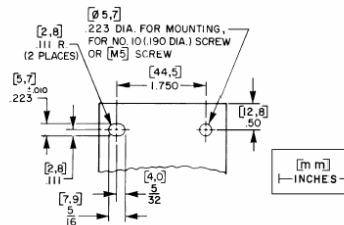

Figure 2. General Purpose Enclosure

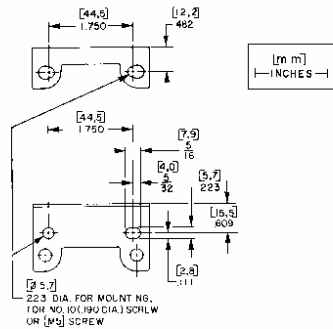

Figure 3. Optional Mounting Bracket

**Piping/Tubing (Pressure Transducer)**

Adequate support of piping and proper mounting of switch should be made to avoid excessive shock or vibration. To minimize the effect of vibration on a switch, mount perpendicular to vibration. Connect piping or tubing to switch at base of transducer. It is recommended that flexible tubing be used whenever possible. Apply pipe compound sparingly to male pipe threads only. If applied to female threads, the compound may enter the transducer and cause operational difficulty. Avoid pipe strain on switch by properly supporting and aligning piping. When tightening pipe, do not use switch as a lever. Use wrenching flats provided at base of transducer for tightening. Locate wrenches on transducer body or piping as close as possible to connection point.

**IMPORTANT:** For steam service, install a condensate loop (pigtail or steam syphon tube) directly into the pressure transducer.

**CAUTION:** To avoid damage to the transducer body, DO NOT OVERTIGHTEN PIPE CONNECTIONS. If TEFLON® tape, paste or similar lubricant is used, use extra care due to reduced friction.

**IMPORTANT:** To eliminate the effect of undesirable pressure fluctuations in the system, install a surge suppressor.

**Wiring**

Wiring must comply with local codes and the National Electrical Code. Use No 14 AWG cooper wire rated for 60°C minimum. The switch housing has a wire clamp and ground in screw. Switch is marked NO for Normally Open, NC for Normally Closed, and C for Common. The general purpose switch enclosure is provided with a 7/8" diameter hole to accommodate 1/2" electrical hub or connector. The watertight switch enclosure has a 1/2" conduit hub. It is recommended that a flexible conduit connection be used. If rigid conduit is used, do not use it as a means of supporting (mounting).

**IMPORTANT:** Electrical load must be within range stated on nameplate. Failure to stay within the electrical range of the switch rating may result in damage to or premature failure of the electrical switch.

**CAUTION:** Do not exert excessive screwdriver force on snap switch when making terminal connections. When connections are made, be sure there is no stress on the wire leads. Either condition may cause malfunction of switch.

\*DuPont's Registered Trademark

| ELECTRICAL RATINGS     |  |  |
|------------------------|--|--|
| Switch Unit            | Rated for Limit Controls and Pressure Operated Switches                          | Rated for Industrial Controls and Temperature Indicating and Regulating Equipment  |
| Standard Switch Rating | 5 Amps Res., 125 VAC<br>5 Amps Res., 250 VAC<br>1/8 HP 125 VAC<br>1/4 HP 250 VAC | 15 Amps Res., 125 VAC<br>10 Amps Res., 250 VAC<br>1/8 HP 125 VAC<br>1/4 HP 250 VAC |

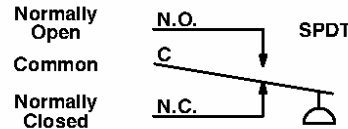

Figure 4. Schematic

**INSTALLATION OF TEMPERATURE TRANSDUCERS**

**Direct Probe**

The direct probe (local) temperature transducer is provided with 1/2" NPT connection. When installing, do not use switch unit as a lever for tightening. Use wrenching flats provided at base of transducer for tightening.

**Capillary and Bulb**

The capillary and bulb (remote) temperature transducers are provided with a length of capillary and a 3/8" diameter sensing bulb.

**CAUTION:** Do not bend capillary at sharp angles. For proper operation, be sure sensing bulb is completely immersed in fluid and not in contact with heating element or anything that would directly affect the temperature of the fluid being sensed.

**Thermal Well (Optional Feature)**

A thermal well may be used for capillary and bulb (remote) or direct probe (local) temperature transducers. The thermal well affords protection for the sensing bulb and allows removal of the sensing bulb while maintaining a pressure tight vessel. When installing sensing bulb in thermal well, be sure that it is fully inserted. Where a thermal well already exists, jam nuts may be obtained to adapt the capillary and bulb to the existing thermal well. The existing thermal well must be for a 3/8" diameter sensing bulb.

**Union Connector (Optional Feature)**

A union connector will allow direct mounting of the sensing bulb in the fluid being controlled. Install union into piping connection before tightening union onto bulb. For maximum performance, the bulb should be inserted in the union connection so that the end of the sensing bulb is even with the end of the union connector nut. Do not apply excessive torque when tightening union connector nut.

**Adjustment (Signal Setting) of Limited Adjustable Deadband Switch**

When facing switch with the switch in the upright position, the adjusting nut on the top adjusts the signal setting (set point increasing). The knob in the front center of the switch adjusts the deadband (set point decreasing) refer to Figure 6. To make adjustments, a 1/4" wrench or screwdriver is required. A pressure or temperature gage (within suitable range) is also required.

If electrical connection (to line of final application) of the switch is not desirable, a battery-powered test lamp or ohmmeter may be used. Pressure or temperature range scales may be used for initial signal settings. These will be accurate within 5%. Adjust switch until indicator is in the middle of the solid red line below the desired range. For exact signal settings, proceed as follows:

**Adjustment (Signal Setting) of Normally Closed or Normally Open Limited Adjustable Deadband Switch**

(Refer to Figure 5)

1. If the limited adjustable deadbands switch is in the line of final application when adjustment (signal setting) is made, be sure switch can be test operated without affecting other equipment.
2. On general purpose and raintight constructions, remove switch cover.
3. Turn adjusting nut at top of switch clockwise until setting indicator is fully up. Turn deadband adjusting knob on front of switch clockwise as far as possible.

**CAUTION: Adjusting nut and knob will turn easily until they hit a stop. Do not over torque. Over torquing may cause damage.**

4. Follow the steps in the chart below to make signal settings.

| Adjustment Procedures  | NORMALLY CLOSED |                     | NORMALLY OPEN   |                     |
|--|-----------------|---------------------|-----------------|---------------------|
|  | Switch Terminal | Test Lamp On-Off    | Switch Terminal | Test Lamp On-Off    |
| 1. Starting with zero signal, connect test lamp to common.   | NC              | On (Closed Circuit) | NO              | Off (Open Circuit)  |
| 2. Apply desired actuation signal. Then back off (counterclockwise) top adjusting nut until switch actuates (set point increasing).                  | NC              | Off (Open Circuit)  | NO              | On (Closed Circuit) |
| 3. Lower signal to desired reactivation signal. Then turn dead band adjusting knob counterclockwise until switch reactivates (set point decreasing). | NC              | On (Closed Circuit) | NO              | Off (Open Circuit)  |

5. Cycle between two desired signals and make minor adjustments to adjusting nut and knob as required to achieve exact set points.
6. After settings have been made, make permanent electrical connections.

**Testing of Installation**

If the adjustment of the switch has been made outside of the line of final application, the switch should be retested when installed in the line of final application. Follow adjustment instructions. Be sure switch can be test operated without affecting other equipment.

**MAINTENANCE**

**▲ WARNING:** To prevent the possibility of personal injury or property damage, turn off electrical power and depressurize switch unit before inspection or removal.

**IMPORTANT:** Switch is not field repairable. The switch must be returned to the factory (Automatic Switch Company, Florham Park, New Jersey) or serviced only by an authorized factory representative. Address all service inquiries to Automatic Switch Company, 50-60 Hanover Road, Florham Park, New Jersey 07932, Valve

**Service Department.** The only adjustments which may be performed on the switch are the adjustment of the set point and deadband and replacement of the transducer unit. Replacement of transducer should be done only if external leakage is evident.

**Preventive Maintenance**

- While in service, operate the switch (cycle between desired signals) at least once a month to insure proper operation. If necessary, electrical wiring and pipe connection should be made so that switch can be test operated without affecting other equipment.
- Periodic inspection of the switch, external surfaces only, should be carried out. Switch should be kept clean and free from paint, foreign matter, corrosion, icing, and freezing conditions.
- Keep the medium entering the transducer as free as possible from dirt and foreign material.

**Causes of Improper Operation**

Switch will not actuate or actuates and reactuates undesirable.

- **Incorrect Electrical Connection:** Check leads to switch. Be sure they are properly connected. Switch is marked *NO* for Normally Open, *NC* for Normally Closed and *C* for Common.
- **Faulty Control Circuit:** Check electrical power supply to switch. Check for loose or blown fuses, open-circuited or grounded wires, loose connections at terminal block or switch. See nameplate for electrical rating and range.
- **Incorrect Adjustment:** Check adjustment of set point and deadband for proper setting. Refer to adjustment instructions.
- **External Leakage:** Check to see that bolts (4) holding transducer to pressure switch are properly torqued to 80 ± 10 in-lbs [9,0 ± 1,1 Nm]. If bolts are tight and leakage is still evident, replace transducer. Refer to paragraph on *Assembly of Switch Unit and Transducer Unit*.
- **Excessive Vibration or Surges Causing Switch to Actuate and Reactuate:** Check for fluctuations in system and install pressure surge suppressor. Check switch mounting and be sure there is no excessive vibration.
- **Incorrect Pressure:** Check pressure in system with suitable pressure gage. Pressure must be within range specified on nameplate.
- **Incorrect Temperature:** Check temperature in system with suitable thermometer. Temperature must be within range specified on nameplate. Check location of capillary and bulb for incorrect mounting. Refer to paragraphs on *Installation of Temperature Transducers*.

If the operation of the switch cannot be corrected by the above means, the entire switch unit should be replaced or an authorized factory representative consulted.

**FOR SERVICE, REPLACEMENT, OR NEW TRANSDUCER**

Consult Factory, or Authorized Factory Representative or Distributors

**ORDERING INFORMATION**

For Limited Adjustable Deadband Switch or New Transducer When Ordering, Specify Catalog Numbers, Fluid, Pressure Range, Temperature Range, Serial Numbers, and Proof Pressure or Rated Overrange Temperature.

**NAMEPLATES ARE LOCATED ON SWITCH COVER AND BOTTOM OF TRANSDUCER**

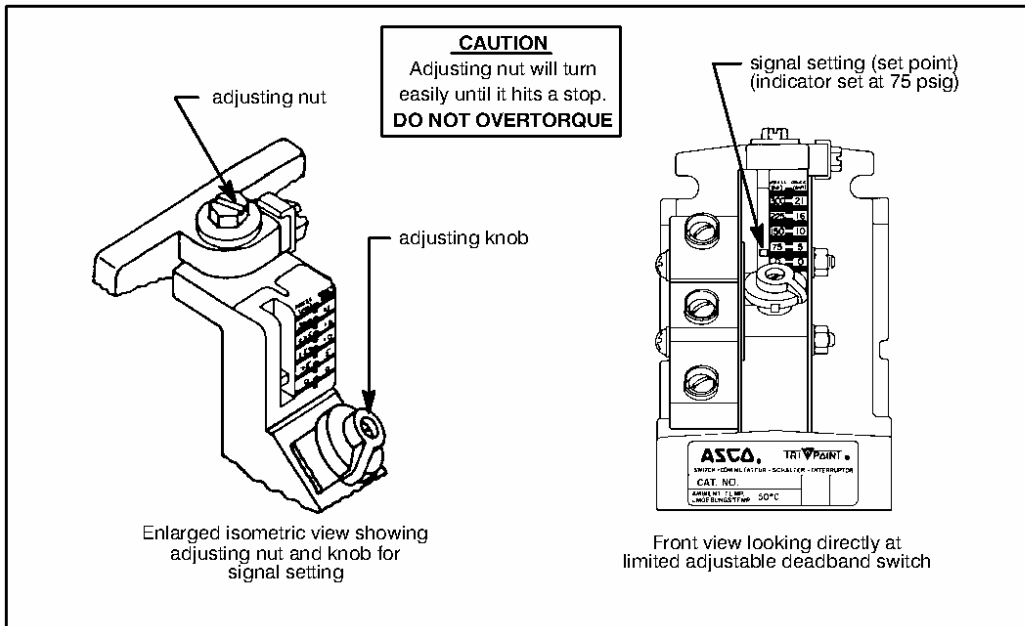

Figure 5. Adjustment (Signal Setting) of Limited Adjustable Deadband Switch.

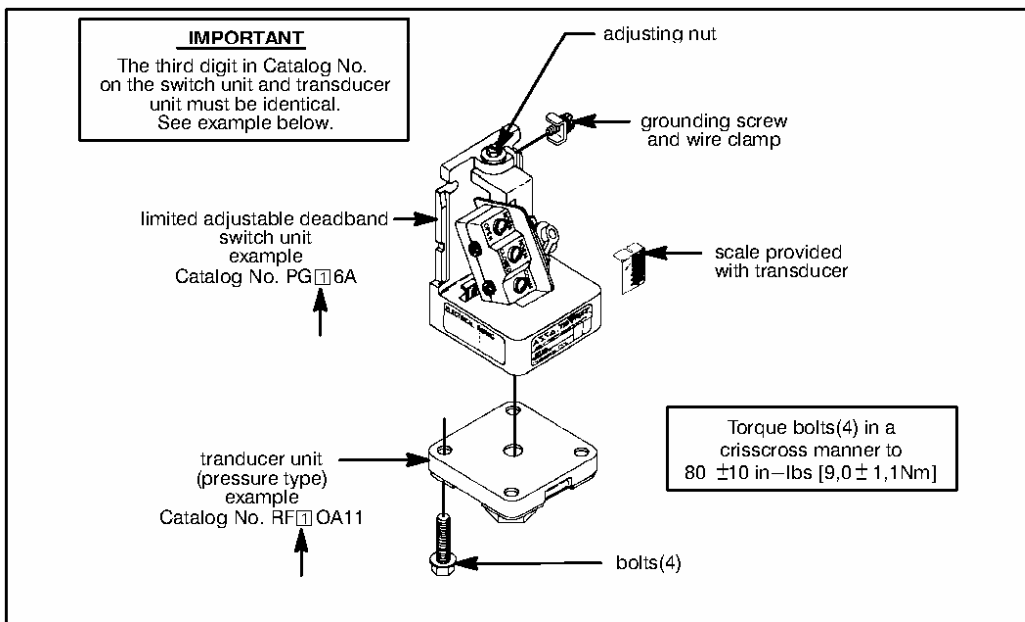

Figure 6. Open-Frame Switch Unit and Transducer Unit to be assembled.

# INSTALLATION & MAINTENANCE INSTRUCTIONS

## ASCO® TRIPPOINT® Pressure Switches SWITCH UNIT AND TRANSDUCER UNIT COMBINATIONS LIMITED ADJUSTABLE DEADBAND COMPACT LINE PRESSURE SWITCHES

OPEN-FRAME, GENERAL PURPOSE, RAINLIGHT OR WATERTIGHT SWITCH ENCLOSURES

**SERIES**

PG10 PG20 PG30  
PG11 PG21 PG31  
PG14 PG24 PG34  
PG16 PG26 PG36

Form No. P7090

**DESCRIPTION**

This sheet lists switch unit and transducer unit combinations. Table I helps to insure that the proper switch unit is assembled to the proper transducer unit, thus providing a complete limited adjustable deadband pressure switch.

In Table I locate the switch unit catalog number being used. Then go to the right on the same line as the switch unit catalog number and find the transducer unit catalog number which may be used with this particular switch unit. **IMPORTANT:** The third digit in both the switch unit and transducer unit catalog numbers must be identical. For example, a Switch Unit Catalog No. PG20A can be used with Transducer Unit Catalog No. RE20A11. The mating produces a complete limited adjustable deadband pressure switch, Catalog No. PG20A/RE20A11. Note that the third digits in both catalog numbers are identical. If the third digits are not identical, it is an incorrect mate and the units should not be assembled.

NOTE: Switch units listed to the left may be used with any transducer units listed to right provided they are on the same horizontal line.

| SWITCH UNITS              |   |   |                | RANGE                                 |                                     |                                | PRESSURE TRANSDUCER UNITS |   |                    |                                |                           |
|---------------------------|---|---|----------------|---------------------------------------|-------------------------------------|--------------------------------|---------------------------|---|--------------------|--------------------------------|---------------------------|
| General Purpose Enclosure | Epoxy Painted Steel Raintight Enclosure | 316® Stainless Steel Watertight Enclosure | Open-Frame     | Adjustable Operating Range (P.S.I.G.) | Rated Overrange Pressure (P.S.I.G.) | Adjustable Deadband (P.S.I.G.) | Aluminum and Buna "N"     | Nylon with Threaded Brass Insert and Buna "N" | Brass and Buna "N" | 303 Stainless Steel and VITON® | All 316 Stainless Steel ④ |
| Catalog Number            | Catalog Number                          | Catalog Number                            | Catalog Number |                                       |                                     | From/ To                       | Catalog Number            | Catalog Number                                | Catalog Number     | Catalog Number                 | Catalog Number            |
| PG30A                     | PG31A                                   | PG34A                                     | PG36A          | 0 - 9                                 | 60                                  | 0.7 - 1.3                      | RD30A11                   | RD30A71                                       | RD30A21 ②          | RD30A32 ②                      | —                         |
| PG20A                     | PG21A                                   | PG24A                                     | PG26A          | 2 - 18                                | 60                                  | 0.8 - 2.1                      | RD20A11                   | RD20A71                                       | RD20A21 ②          | RD20A32 ②                      | —                         |
| PG30A                     | PG31A                                   | PG34A                                     | PG36A          | 2 - 18                                | 100                                 | 1.8 - 3.1                      | —                         | —   | —                  | —                              | RE30A44                   |
| PG20A                     | PG21A                                   | PG24A                                     | PG26A          | 4 - 36                                | 150                                 | 2.0 - 4.0                      | RE20A11                   | RE20A71                                       | RE20A21 ②          | RE20A32 ②                      | RE20A44                   |
| PG10A                     | PG11A                                   | PG14A                                     | PG16A          | 6 - 60                                | 150                                 | 2.1 - 4.6                      | RE10A11                   | RE10A71                                       | RE10A21 ②          | RE10A32 ②                      | RE10A44                   |
| PG10A                     | PG11A                                   | PG14A                                     | PG16A          | 10 - 100                              | 200 ①                               | 4.0 - 8.0                      | RF10A11                   | RF10A71 ①                                     | RF10A21 ②          | RF10A32 ②                      | RF10A44                   |
| PG10A                     | PG11A                                   | PG14A                                     | PG16A          | 20 - 200                              | 400 ①                               | 8.0 - 17                       | RG10A11                   | RG10A71 ①                                     | RG10A21 ②          | RG10A32 ②                      | RG10A44                   |
| PG10A                     | PG11A                                   | PG14A                                     | PG16A          | 30 - 300                              | 450                                 | 15 - 25                        | RH10A11                   | —   | RH10A21 ②          | RH10A32 ②                      | RH10A44                   |
| PG10A                     | PG11A                                   | PG14A                                     | PG16A          | 40 - 400                              | 500                                 | 22 - 45                        | RJ10A11                   | —   | RJ10A21 ②          | RJ10A32 ②                      | RJ10A44                   |
| PG20A                     | PG21A                                   | PG24A                                     | PG26A          | 60 - 600                              | 2000                                | 35 - 75                        | —                         | —   | RL20A21            | RL20A42 ③                      | —                         |
| PG10A                     | PG11A                                   | PG14A                                     | PG16A          | 100 - 1000                            | 2000                                | 65 - 110                       | —                         | —   | RL10A21            | RL10A42 ③                      | —                         |
| PG20A                     | PG21A                                   | PG24A                                     | PG26A          | 160 - 1650                            | 4500                                | 190 - 290                      | —                         | —   | RN20B21            | RN20B42 ③                      | —                         |
| PG10A                     | PG11A                                   | PG14A                                     | PG16A          | 270 - 2700                            | 4500                                | 200 - 300                      | —                         | —   | RN10B21            | RN10B42 ③                      | —                         |
| PG10A                     | PG11A                                   | PG14A                                     | PG16A          | 600 - 6000                            | 7500                                | 300 - 500                      | —                         | —   | —                  | RQ10B42 ③                      | —                         |
| PG30A                     | PG31A                                   | PG34A                                     | PG36A          | 0-30" Hg (VAC)                        | 50                                  | 1.2-2.7" Hg                    | RV34A11                   | —   | RV34A21            | RV34A32                        | —                         |
| PG20A                     | PG21A                                   | PG24A                                     | PG26A          | 30"Hg(V)-14 psig                      | 50                                  | 2.4-5.4" Hg                    | RV24A11                   | —   | RV24A21            | RV24A32                        | —                         |

IMPORTANT: All units listed above are suitable for air and hydraulic oil service. For water service, all units are suitable except aluminum.

**NOTES:**

- ① Rated overrange pressure on RF10A71 is 150 psig and on RG10A71 is 300 psig.
- ② These transducers are acceptable for steam service if used with pigtail (condensate loop) between steam line and transducer.
- ③ Transducers ending in 42 have 316 stainless steel bodies, not 303 stainless steel.
- ④ 316 stainless steel transducer deadbands are approximately 30% greater than values shown.
- ⑤ To make switch enclosure Type 4 watertight, a watertight conduit hub must be installed in the 7/8" diameter hole. Use conduit hub part No.PP01 or equivalent.

Form No. P7090

Printed in U.S.A.

Automatic Switch Co. 50-60 Hanover Road, Florham Park, New Jersey 07932



© Automatic Switch Co. NCM100001. All Rights Reserved.

# INSTALLATION & MAINTENANCE INSTRUCTIONS

## ASCO® TRI-POINT® Temperature Switches

SWITCH UNIT AND TRANSDUCER UNIT COMBINATIONS

LIMITED ADJUSTABLE DEADBAND COMPACT LINE TEMPERATURE SWITCHES  
OPEN-FRAME, GENERAL PURPOSE, RAINTIGHT OR WATERTIGHT SWITCH ENCLOSURES

SERIES

PG10 PG14

PG15 PG16

Form No. P7090

### DESCRIPTION

This sheet lists switch unit and transducer unit combinations. Table II helps to insure that the proper switch unit is assembled to the proper transducer unit, thus providing a complete limited adjustable deadband temperature switch.

In Table II locate the switch unit catalog number being used. Then go to the right on the same line as the switch unit catalog number and find the transducer unit catalog number which may be used with this particular switch unit. **IMPORTANT:** The third digit in both the switch unit and transducer unit catalog numbers must be identical. For example, a Switch Unit Catalog No. PG10A can be used with Transducer Unit Catalog No. KA10A1. The mating produces a complete limited adjustable deadband temperature switch, Catalog No. PG10A/KA10A1. Note that the third digits in both catalog numbers are identical. If the third digits are not identical, it is an incorrect mate and the units should not be assembled.

NOTE: Switch units listed to the left may be used with any transducer units listed to right provided they are on the same horizontal line.

| SWITCH UNITS              |   |  |                | RANGE                          |                                   |                                 | TEMPERATURE TRANSDUCER UNITS |                     |                       |                     |                        |                     |
|---------------------------|---|--|----------------|--------------------------------|-----------------------------------|---------------------------------|------------------------------|---------------------|-----------------------|---------------------|------------------------|---------------------|
| General Purpose Enclosure | Epoxy Painted Steel Raintight Enclosure | 316 ② Stainless Steel Watertight Enclosure | Open-Frame     | Adjustable Operating Range °F. | Rated Overrange Temperature °F. ① | Adjustable Deadband °F. From/To | Direct Mount                 |                     | 6" Capillary and Bulb |                     | 12" Capillary and Bulb |                     |
|                           |   |  |                |                                |                                   |                                 | Copper                       | 316 Stainless Steel | Copper                | 316 Stainless Steel | Copper                 | 316 Stainless Steel |
| Catalog Number            | Catalog Number                          | Catalog Number                             | Catalog Number |                                |                                   |                                 | Catalog Number               | Catalog Number      | Catalog Number        | Catalog Number      | Catalog Number         | Catalog Number      |
| PG10A                     | PG11A                                   | PG15A                                      | PG16A          | -60 - 20                       | 200                               | 6 - 12                          | KA10A1                       | KA10A4              | KA11A1                | KA11A4              | KA11A1D                | KA11A4D             |
| PG10A                     | PG11A                                   | PG15A                                      | PG16A          | -30 - 60                       | 250                               | 6 - 12                          | KB10A1                       | KB10A4              | KB11A1                | KB11A4              | KB11A1D                | KB11A4D             |
| PG10A                     | PG11A                                   | PG15A                                      | PG16A          | 0 - 90                         | 300                               | 6 - 12                          | KD10A1                       | KD10A4              | KD11A1                | KD11A4              | KD11A1D                | KD11A4D             |
| PG10A                     | PG11A                                   | PG15A                                      | PG16A          | 50 - 160                       | 360                               | 6 - 12                          | KF10A1                       | KF10A4              | KF11A1                | KF11A4              | KF11A1D                | KF11A4D             |
| PG10A                     | PG11A                                   | PG15A                                      | PG16A          | 100 - 220                      | 450                               | 6 - 12                          | KJ10A1                       | KJ10A4              | KJ11A1                | KJ11A4              | KJ11A1D                | KJ11A4D             |
| PG10A                     | PG11A                                   | PG15A                                      | PG16A          | 160 - 260                      | 500                               | 6 - 12                          | KL10A1                       | KL10A4              | KL11A1                | KL11A4              | KL11A1D                | KL11A4D             |
| PG10A                     | PG11A                                   | PG15A                                      | PG16A          | 225 - 340                      | 600                               | 6 - 12                          | —                            | —                   | KN11A1                | KN11A4              | KN11A1D                | KN11A4D             |
| PG10A                     | PG11A                                   | PG15A                                      | PG16A          | 300 - 450                      | 700                               | 6 - 12                          | —                            | —                   | KT11A1                | KT11A4              | KT11A1D                | KT11A4D             |
| PG10A                     | PG11A                                   | PG15A                                      | PG16A          | 350 - 510                      | 800                               | 6 - 12                          | —                            | —                   | KU11A1                | KU11A4              | KU11A1D                | KU11A4D             |

NOTE:

① Rated overrange temperatures are limited as follows:

For copper capillary units: 550°F (288°C).

For direct mount units: 260°F (127°C).

② To make switch enclosure Type 4 watertight, a watertight conduit hub must be installed in the 7/8" diameter hole. Use conduit hub part No. PP01 or equivalent.

Form No. P7090

Printed in U.S.A.

Automatic Switch Co. 50-60 Hanover Road, Florham Park, New Jersey 07932



© Automatic Switch Co. MCN LXXXVI. All Rights Reserved.





**UNDERWRITERS LABORATORIES, INC. LISTED  
AND/OR RECOGNIZED COMPONENTS**

**ASCO® TRIPONT® Compact Line  
Pressure Switches**



Form No. P7047R1

**UL LISTINGS**

This sheet is a listing of switch unit and transducer unit combinations that are Listed and/or Component Recognized by Underwriters Laboratories, Inc. The table below is provided to insure that the proper switch unit (section) is assembled to the proper transducer unit (section), thus providing a complete, UL Listed and/or Recognized Component pressure switch. Only completely assembled combinations are UL Listed and/or Recognized Component. See table below for UL complementary product category listing and guide card numbers.

**INSTALLATION INSTRUCTIONS**

To determine the proper switch and transducer combinations, first locate the switch unit catalog number in the table below. Then going to the right on the same line (as the switch unit catalog number) find the transducer unit catalog number which may be used with this particular switch unit.

**IMPORTANT:** The third digit in both the switch unit and transducer unit catalog numbers must be identical. For example, a switch unit Catalog No. PA31A can be used with transducer unit Catalog No. RV34A11. The mating produces a complete pressure switch Catalog No. PA31A/RV34A11.

| SWITCH UNITS<br>See Note ④                           |                                   |   |                           |                    |   | PRESSURE TRANSDUCER UNITS<br>See Notes ①, ② & ③                            |  |  |           |
|--|-----------------------------------|---|---------------------------|--------------------|---|--|--|--|-----------|
| Series: PA, PB, PC & PG<br>Followed by Numbers Below |                                   |   |                           |                    |   |  |  |  |           |
| General Purpose Enclosure Type 1                     | Watertight Enclosure Types 3 & 3S | Watertight Enclosure Types 3, 3S, 4 & 6 | Open-Frame (No Enclosure) | Applicable Options |   | Air - Water Non-Hazardous Gas & Oil Polyester, Brass & Buna N Construction | Air - Water Non-Hazardous Gas, Oil & Steam Brass, Buna N & VITON* Construction | Corrosive Fluids Air - Water Non-Hazardous Gas & Oil 303 Stainless Steel & VITON* Construction |           |
| 40A  | 41A                               | 44A                                     | 48A                       | 46A                | Series PA, PB, PC & PG - 4A with Suffix I Enclosure Types 4, 4X & 6 Optional Suffixes 1, 2, 3, J & K. | RD40A11  | RD40A71  | RD40A21  | RD40A32   |
| 30A  | 31A                               | 34A                                     | 38A                       | 36A                |   | RV34A11  | —  | RV34A21  | RV34A32   |
| 20A  | 21A                               | 24A                                     | 28A                       | 26A                |   | RV24A11  | —  | RV24A21  | RV24A32   |
| 30A  | 31A                               | 34A                                     | 38A                       | 36A                |   | RD30A11  | RD30A71  | RD30A32 ②  | RD30A32 ② |
| 20A  | 21A                               | 24A                                     | 28A                       | 26A                |   | RD20A11  | RD20A71  | RD20A21 ②  | RD20A32 ② |
| 30A  | 31A                               | 34A                                     | 38A                       | 36A                |   | —  | —  | —  | —         |
| 20A  | 21A                               | 24A                                     | 28A                       | 26A                |   | RE20A11  | RE20A11  | RE20A21 ②  | RE20A32 ② |
| 10A  | 11A                               | 14A                                     | 18A                       | 16A                |   | RE10A11  | RE10A71  | RE10A21 ②  | RE10A32 ② |
| 10A  | 11A                               | 14A                                     | 18A                       | 16A                |   | RF10A11  | RF10A71  | RF10A21 ②  | RF10A32 ② |
| 10A  | 11A                               | 14A                                     | 18A                       | 16A                |   | RG10A11  | RG10A71  | RG10A21 ②  | RG10A32 ② |
| 10A  | 11A                               | 14A                                     | 18A                       | 16A                |   | RH10A11  | —  | RH10A21 ②  | RH10A32 ② |
| 10A  | 11A                               | 14A                                     | 18A                       | 16A                |   | RJ10A11  | —  | RJ10A21  | RJ10A32 ② |
| 20A  | 21A                               | 24A                                     | 28A                       | 26A                |   | —  | —  | 316 St. St. & VITON*<br>RL20A21  | RL20A42   |
| 10A  | 11A                               | 14A                                     | 18A                       | 16A                |   | —  | —  | RL10A21  | RL10A42   |
| 20A  | 21A                               | 24A                                     | 28A                       | 26A                |   | —  | —  | RN20B21  | RN20B42   |
| 10A  | 11A                               | 14A                                     | 18A                       | 16A                | —   | —  | RN10B21  | RN10B42  |           |
| 10A  | 11A                               | 14A                                     | 18A                       | 16A                | —   | —  | —  | RQ10B42  |           |

**NOTES:**

- ① All transducers used with general purpose and watertight switch units are UL Listed as Industrial Control Equipment—Enclosed, Motor Controllers —Pressure Operated, Guide NKPZ. Transducers which end in 11, 21, 32 or 42 and used with General Purpose and Watertight Switch Units are also UL Listed as Switches for Heating and Cooling Appliances, Guide MFHX.
- ② All transducers used with open-frame (no enclosure) switch units are considered UL Recognized Components as Industrial Control Equipment, Motor Controllers — Pressure Operated, Guide NKPZ2. Transducers which end in 11, 21, 32, or 42 and used with open-frame (no enclosure) switch units are also considered UL Recognized Components as Switches for Heating and Cooling Appliances, Guide MFHX2.
- ③ When used for steam service, these transducers with general purpose and watertight switch units are also UL Listed as Limit Controls, Guide MBPR.
- ④ Transducers used with open-frame (no enclosure) switch units are considered UL Recognized Component Limit Controls, Guide MBPR2.
- ⑤ Suffix B is an applicable option.
- ⑥ Series PC10A, PC11A, PC16A, PC20A, PC21A, PC26A, PC30A, PC31A & PC36A are UL Recognized Components for use as Motor Controller — Pressure Operated (NKPZ2).

\* DuPont's registered trademark.

Form No. P7047R1

Printed in U.S.A.

Automatic Switch Co. 50-60 Hanover Road, Florham Park, New Jersey 07932



© Automatic Switch Co. NCHLXXXXVII. All Rights Reserved.



**UNDERWRITERS LABORATORIES, INC. LISTED  
AND/OR RECOGNIZED COMPONENTS**

**ASCO® TRIPPOINT® Compact Line  
Temperature Switches**



Form No.P7047R1

**UL LISTINGS**

This sheet is a listing of switch unit and transducer unit combinations that are Listed and/or Component Recognized by Underwriters Laboratories, Inc. The table below is provided to insure that the proper switch unit (section) is assembled to the proper transducer unit (section), thus providing a complete, UL Listed and/or Recognized Component temperature switch. Only completely assembled combinations are UL Listed and/or Recognized Component. See table below for UL complementary product category listing and guide card numbers.

**INSTALLATION INSTRUCTIONS**

To determine the proper switch and transducer combinations, first locate the switch unit catalog number in the table below. Then going to the right on the same line (as the switch unit catalog number) find the transducer unit catalog number which may be used with this particular switch unit.

**IMPORTANT:** The third digit in both the switch unit and transducer unit catalog numbers must be identical. For example, a switch unit Catalog No.PA10A can be used with transducer unit Catalog No.KB10A4. The mating produces a complete temperature switch Catalog No. PA10A/KB10A4.

| SWITCH UNITS  |                                   |   |                           |                    |  | TEMPERATURE TRANSDUCER UNITS |                     |                            |                                       |                       |
|---|-----------------------------------|---|---------------------------|--------------------|--|------------------------------|---------------------|----------------------------|---------------------------------------|-----------------------|
| Series: PA, PB, PC, & PG<br>Followed by Numbers Below |                                   |   |                           |                    |  | See Notes ① and ②            |                     |                            |                                       |                       |
| General Purpose Enclosure Type 1                      | Watertight Enclosure Types 3 & 3S | Watertight Enclosure Types 3, 3S, 4, 5, 6 | Open-Frame (No Enclosure) | Applicable Options | Series PA, PB, PC & PG, 4A with Suffix 1 Enclosure Types 4, 4X & 6 Optional Suffixes 1, 2, 3, J & K. | Direct Probe                 |                     | 6' Capillary & Bulb        |                                       | Applicable Options    |
|   |                                   |   |                           |                    |  | Copper                       | 316 Stainless Steel | Copper (Armored Capillary) | 316 Stainless Steel (Plain Capillary) |                       |
| 10A   | 11A                               | 15A                                       | 19A                       | 16A                |  | KA10A1                       | KA10A4              | KA11A1                     | KA11A4                                | Suffixes D, E, F, & G |
| 10A   | 11A                               | 15A                                       | 19A                       | 16A                |  | KB10A1                       | KB10A4              | KB11A1                     | KB11A4                                |                       |
| 10A   | 11A                               | 15A                                       | 19A                       | 16A                |  | KD10A1                       | KD10A4              | KD11A1                     | KD11A4                                |                       |
| 10A   | 11A                               | 15A                                       | 19A                       | 16A                |  | KF10A1                       | KF10A4              | KF11A1                     | KF11A4                                |                       |
| 10A   | 11A                               | 15A                                       | 19A                       | 16A                |  | KJ10A1                       | KJ10A4              | KJ11A1                     | KJ11A4                                |                       |
| 10A   | 11A                               | 15A                                       | 19A                       | 16A                |  | KL10A1                       | KL10A4              | KL11A1                     | KL11A4                                |                       |
| 10A   | 11A                               | 15A                                       | 19A                       | 16A                |  | —                            | —                   | KN11A1                     | KN11A4                                |                       |
| 10A   | 11A                               | 15A                                       | 19A                       | 16A                |  | —                            | —                   | KT11A1                     | KT11A4                                |                       |
| 10A   | 11A                               | 15A                                       | 19A                       | 16A                |  | —                            | —                   | KU11A1                     | KU11A4                                |                       |

**NOTES:**

- ① All transducers used with general purpose and watertight switch units are UL Listed as Temperature — Indicating and Regulating Equipment, Guide XAPX.
- ② All transducers used with open frame (no enclosure) switch units are considered UL Recognized Components as Temperature — Indicating and Regulating Equipment Guide XAPX2.

- ② Optional features, armored capillary, and capillary length identified by the seventh, eighth, and ninth digit codes respectively of the transducer catalog number are also UL Listed.

Form No. P7047R1

Printed in U.S.A.

Automatic Switch Co. 50-60 Hanover Road, Florham Park, New Jersey 07932



© Automatic Switch Co. MCMXXVII. All Rights Reserved.

# Installation & Maintenance Instructions

## OPEN-FRAME SOLENOIDS

**SERIES  
U8016  
US8016**

Form No.V6917R1

**NOTICE:** See separate valve installation and maintenance instructions for information on: Operation, Positioning, Mounting, Piping, Strainer or Filter Requirements, Flow Controls, Cleaning, Preventive Maintenance, Causes of Improper Operation, Disassembly and Reassembly of Basic Valve.

### DESCRIPTION

Series U8016 are open-frame, pull type solenoid operators. When installed just as a solenoid and not as part of an ASCO valve, the core has a 0.250-28 UNF-2B tapped hole with 0.38 minimum full thread.

Series US8016 open-frame solenoid operators are the same as Series U8016 except they are provided with spade terminal coils.

### OPERATION

When the solenoid is energized, the core is drawn into the solenoid base sub-assembly.

**IMPORTANT:** When the solenoid is de-energized, the initial return force for the core, whether developed by spring, pressure or weight, must exert a minimum force to overcome residual magnetism created by the solenoid. Minimum return force for AC construction is 11 ounces; 5 ounces for DC construction.

### INSTALLATION

Check nameplate for correct catalog number, voltage, frequency, wattage and service.

**▲ CAUTION:** To protect the solenoid valve or operator, install a strainer or filter, suitable for the service involved in the inlet side as close to the valve or operator as possible. Clean periodically depending on service conditions. See ASCO Series 8600, 8601 and 8602 for strainers.

**▲ WARNING:** To prevent the possibility of electrical shock from the accessibility of live parts, install the open-frame solenoid in an enclosure.

### Positioning

This solenoid is designed to perform properly when mounted in any position. However, for optimum life and performance, the solenoid should be mounted vertically and upright to reduce the possibility of foreign matter accumulating in the solenoid base sub-assembly area.

If open-frame solenoid is supplied on an ASCO valve, check basic valve instructions for positioning.

### Mounting

Refer to Figure 1 (below) for mounting.

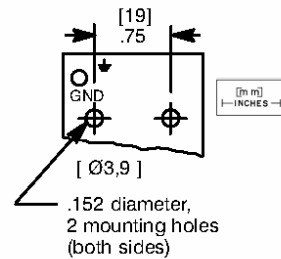

**▲ CAUTION:** Be sure mounting screws do not penetrate yoke far enough to damage coil.

Figure 1. Yoke mounting dimension (partial view).

### Wiring

Wiring must comply with local codes and the National Electrical Code. Coils are provided with lead wires or 1/4" spade terminals. The solenoid yoke is provided with a hole for a grounding screw, see Figure 2. Grounding screw not supplied with solenoid. To facilitate wiring, the solenoid may be rotated 360° by removing the retaining cap, clip or hi-shock clip.

**▲ CAUTION:** When metal retaining clip disengages, it will spring upward.

Rotate solenoid enclosure to desired position. Then replace retaining cap, clip or hi-shock clip before operating. Be sure hi-shock retaining clip seats in the circular groove around side wall of solenoid base sub-assembly. Tighten retaining clip securely so that the retaining clip ends meet.

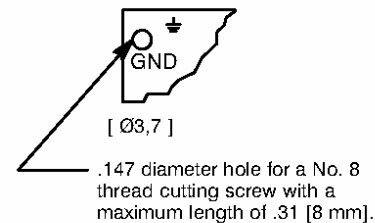

Figure 2. Hole for grounding screw (partial view).

© **ASCO**

MM All Rights Reserved.

Printed in U.S.A.

Page 1 of 4

50 Hanover Road, Florham Park, New Jersey 07932 www.ascovalve.com

Note: Alternating current (AC) and direct current (DC) solenoids are built differently. To convert from one to the other, it is necessary to change the complete solenoid including the core and solenoid base sub-assembly, not just the coil. Consult ASCO.

#### Solenoid Enclosure Assembly

Catalog Numbers U80161, U80162, US80161 and US80162 open-frame solenoids may be assembled as a complete unit. Tightening is accomplished by means of a hex flange at the base of the solenoid.

**▲ CAUTION: Care must be taken not to mar the upper core surface, when installing core or positioning solenoid.**

#### Solenoid Temperature

Standard solenoids are supplied with coils designed for continuous duty service. When the solenoid is energized for a long period, the solenoid yoke becomes hot. This is a safe operating temperature. Any excessive heating will be indicated by the smoke and odor of burning coil insulation.

#### MAINTENANCE

**▲ WARNING: To prevent the possibility of death, serious injury or property damage, turn off electrical power, depressurize solenoid operator or valve, and vent fluid to a safe area before servicing.**

#### Cleaning

All solenoid operators and valves should be cleaned periodically. The time between cleanings will vary depending on the medium and service conditions. In general, if the voltage to the coil is correct, sluggish valve operation, excessive noise or leakage will indicate that cleaning is required. In the extreme case, faulty operation will occur and the solenoid operator or valve may fail to shift. Clean strainer or filter when cleaning the operator or valve.

#### Preventive Maintenance

- Keep the medium flowing through the solenoid operator or valve as free from dirt and foreign material as possible.
- While in service, the solenoid operator or valve should be operated at least once a month to insure proper opening and closing.
- Depending on the medium and service conditions, periodic inspection of internal valve parts for damage or excessive wear is recommended. Thoroughly clean all parts. Replace any worn or damaged parts.

#### Causes of Improper Operation

- **Faulty Control Circuit:** Check the electrical system by energizing the solenoid. A metallic *click* signifies that the solenoid is operating. Absence of the *click* indicates loss of power supply. Check for loose or blown fuses, open-circuited or grounded solenoid, broken lead wires or splice connections.
- **Burned-Out Coil:** Check for open-circuited coil. Replace if necessary. Check supply voltage; it must be the same as specified on nameplate and marked on the

coil. Check ambient temperature and check the core is not jammed.

- **Low Voltage:** Check voltage across the coil leads. Voltage must be at least 85% of rated voltage.

#### Coil Replacement/Solenoid Disassembly

1. Disassemble solenoid in an orderly fashion using exploded views for identification and placement of parts.
2. Disconnect coil lead wires from power supply and grounding wire from yoke.
3. Remove retaining cap, clip or hi-shock clip and spacer (if present) from top of solenoid.

**▲ CAUTION: When metal retaining clip disengages, it will spring upward.**

4. Slip yoke containing coil, sleeves and insulating washers off the solenoid base sub-assembly. Insulating washers are omitted when a molded coil is used.
5. Remove coil, sleeves (2) and insulating washers (if present) from yoke.

Note: for panel mount (Figure 6) or hi-shock (Figure 5) construction remove additional parts as required.

6. For additional disassembly, unscrew solenoid base sub-assembly or bonnet. The bonnet requires a special wrench adapter which is supplied in ASCO Rebuild Kits. For wrench adapter only, order Wrench Kit No. K218948.
7. Refer to basic valve instructions for further disassembly.

#### Coil Replacement/Solenoid Reassembly

1. Install solenoid base sub-assembly or plugnut/core tube sub-assembly with bonnet gasket and bonnet. Torque solenoid base sub-assembly to  $175 \pm 25$  in-lbs [ $19,8 \pm 2,8$  Nm]. Torque valve bonnet to  $90 \pm 10$  in-lbs [ $10,2 \pm 1,1$  Nm].
2. Reassemble open-frame solenoid following exploded views.
3. For solenoid using a hi-shock retaining clip be sure retaining clip seats in circular groove around side wall of solenoid base sub-assembly. Then tighten retaining clip securely so that the retaining clip ends meet.
4. Make electrical connections to solenoid, see *Wiring* section.

**▲ CAUTION: Solenoid must be fully reassembled because the yoke and internal parts complete the magnetic circuit. Be sure to replace insulating washer at each end of non-molded coil.**

#### ORDERING INFORMATION FOR SOLENOID OPERATORS OR COILS

When Ordering Solenoid Operators or Coils, specify Catalog Number, Serial Number, Voltage and Frequency. For Coils, specify number stamped on coil (if visible).

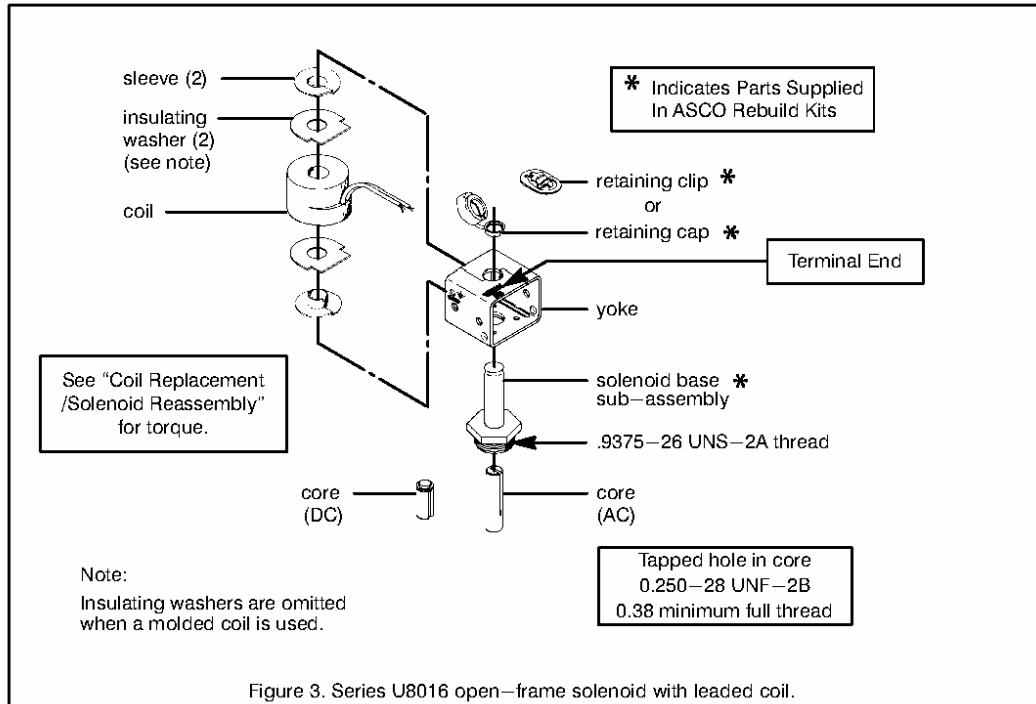

Figure 3. Series U8016 open-frame solenoid with leaded coil.

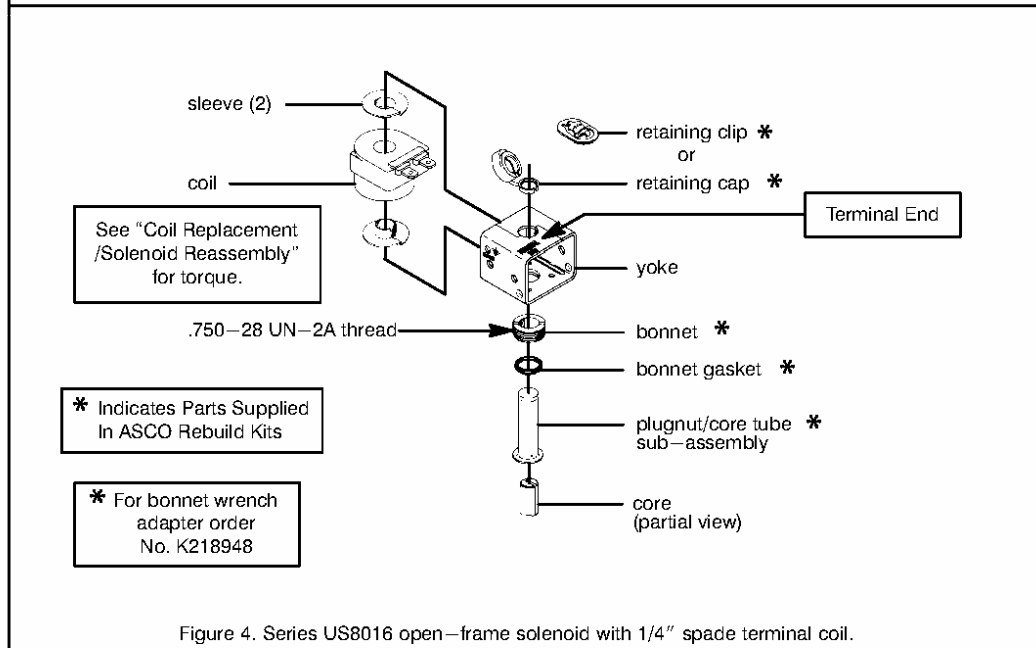

Figure 4. Series US8016 open-frame solenoid with 1/4" spade terminal coil.

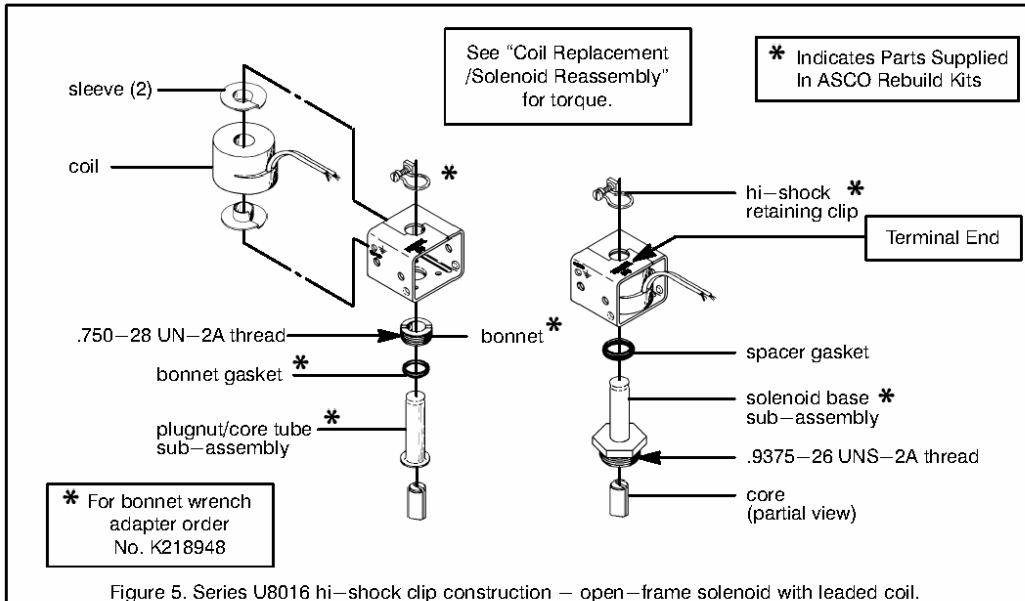

Figure 5. Series U8016 hi-shock clip construction - open-frame solenoid with leaded coil.

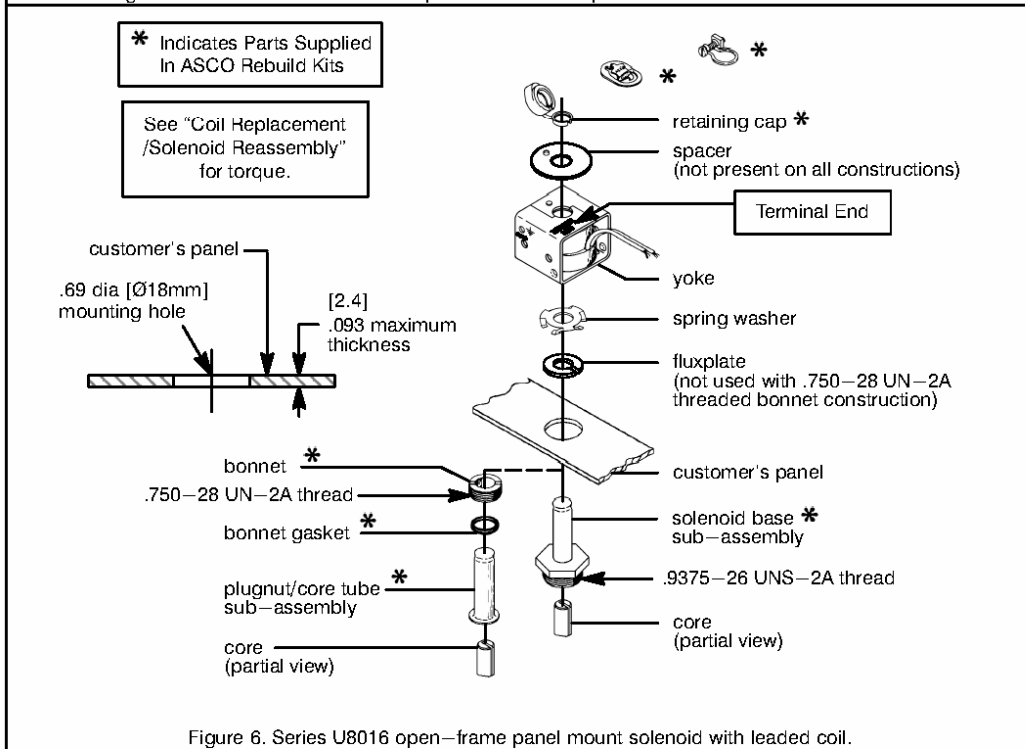

Figure 6. Series U8016 open-frame panel mount solenoid with leaded coil.

# General Installation & Maintenance Instructions

Drawing No.  
214639-107  
October - 2003

## DESCRIPTION

This sheet is specifically designed to provide general installation and maintenance instructions for specially designed valves. Not all paragraphs on this sheet are applicable to each design. You must review this sheet and select the paragraphs which apply to the valves you have. This sheet is designed to cover a wide range of valve designs, for example: solenoid operated valves, air operated valves, manual operated valves, special designs for special applications and conditions. Refer to the offset assembly drawing which is packaged with your valve for information on size, type, material, and operation.

## OPERATION

Refer to assembly drawing for flow diagrams and general instructions on operation.

## INSTALLATION

Check nameplate for correct catalog number, pressure, voltage, service and valve for any other special instruction tags or labels. Never apply incompatible fluids or exceed pressure rating of the valve. Installation and valve maintenance to be performed by qualified personnel.

## FOR VALVES WITH LEVER TYPE OPERATING MOVEMENTS

**▲ WARNING: Do not obstruct movement of lever. Lever must be free to move or valve will not shift position.**

### Future Service Considerations

Provision should be made for performing seat leakage, external leakage, and operational tests on the valve with a nonhazardous, noncombustible fluid after disassembly and reassembly.

### Temperature Limitations

Refer to assembly drawing for ambient and fluid temperature limitations.

### Positioning

Refer to assembly drawing for positioning.

### Piping

Connect piping to valve according to markings on valve body (consult flow diagrams on assembly drawings). Apply pipe compound sparingly to male pipe threads only. If applied to valve threads the compound may enter the valve and cause operational difficulty. Avoid pipe strain by properly supporting and aligning piping. When tightening the pipe, do not use valve or solenoid as a lever. Locate wrenches applied to valve body or piping as close as possible to connection point.

**▲ CAUTION: To avoid damage to the valve body, DO NOT OVERTIGHTEN PIPE CONNECTIONS. If TEFLON† tape, paste, spray or similar lubricant is used, use extra care when tightening due to reduced friction. This applies mainly to valves with aluminum or zinc bodies.**

**▲ CAUTION: For the protection of the solenoid valve (all valves in general) install a strainer or filter suitable for the service involved in the inlet side as close to the valve as possible. Periodic cleaning is required depending on service conditions. See Series 8600, 8601 and 8602 for strainers.**

### Minimum Operating Pressure Differential

For all valves requiring a minimum operating pressure differential, the pressure and exhaust lines must be full size without restriction. Minimum operating pressure differential as stamped on the nameplate must be maintained for dependable operation. For 3 and 4-way valves minimum operating pressure differential must be maintained between pressure and exhaust at the moment of changeover. Hydraulic pumps or air reservoirs must have adequate capacity to maintain the minimum pressure during changeover. To check pressure during changeover, install a pressure gage in the pressure connection as close as possible to the valve.

## MAINTENANCE

**▲ WARNING: To prevent the possibility of death, serious injury or property damage, turn off electrical power and depressurize valve. If the valve handles combustible fluid, extinguish all open flames and avoid any type of sparking or ignition. Vent fluid to a safe area before servicing the valve.**

NOTE: For most valves it is not necessary to remove valve from pipeline for repairs. For air operated valves the auxiliary pressure line must be disconnected.

### Cleaning

All solenoid valves should be cleaned periodically. The time between cleanings will vary depending on the medium and service conditions. In general, if the voltage to the coil is correct, sluggish valve operation, excessive noise or leakage will indicate that cleaning is required. In the extreme case, faulty valve operation will occur and the valve may fail to shift. Clean strainer or filter when cleaning the valve.

### Preventive Maintenance

- Keep medium flowing through valve as free from dirt and foreign material as possible.
- Periodic exercise of the valve should be considered if ambient or fluid conditions are such that corrosion, elastomer degradation, fluid contamination build up, or other conditions that could impede solenoid valve shifting are possible. The actual frequency of exercise necessary will depend on specific operating conditions. A successful operating history is the best indication of a proper interval between exercise cycles.
- Depending on the medium and service conditions, periodic inspection of internal valve parts for damage or excessive wear is recommended. Thoroughly clean all parts. If parts are worn or damaged, install a complete rebuild kit.
- For special designs where an operating movement is utilized, periodic inspection of the movement should be carried out. Operating movement should be kept clean and free from paint, foreign matter, corrosion, freezing and icing conditions.

### Causes Of Improper Operation

- **Faulty Control Circuits:** Check the electrical system by energizing the solenoid. A metallic *click* signifies that the solenoid is operating. Absence of the *click* indicates loss of power supply. Check for loose or blown fuses, open circuited or grounded coil, broken lead wires, or splice connections.
- **Burned-Out Coil:** Check for open-circuited coil. Replace coil as necessary. Check supply voltage; it must be the same as specified on nameplate and as marked on the coil.
- **Low Voltage:** Check coil voltage across coil leads. Voltage must be at least 85% of nameplate rating.
- **Incorrect Pressure:** Check valve pressure. Pressure to valve must be within range specified on nameplate.
- **Air Operator:** Check line pressure to air operator.
- **Excessive Leakage:** Disassemble valve and clean all parts. Replace worn or damaged parts with a complete ASCO Rebuild Kit for best results.

### ORDERING INFORMATION FOR ASCO REBUILD KITS AND COILS

Parts marked with an asterisk (\*) on the assembly drawing are supplied in Rebuild Kits. When Ordering Rebuild Kits for ASCO valves, order the Rebuild Kit number stamped on the valve nameplate. When Ordering Coils for ASCO valves, order the number stamped on your coil. If the number of the kit or the coil is not visible, order by indicating the number of kits required, and the Catalog Number and Serial Number of the valve(s) for which they are intended.

† Dupont Co. Registered Trademark

**ASCO®**

50 Hanover Road, Florham Park, New Jersey 07932 www.ascovalve.com

V5779R4

All Rights Reserved.

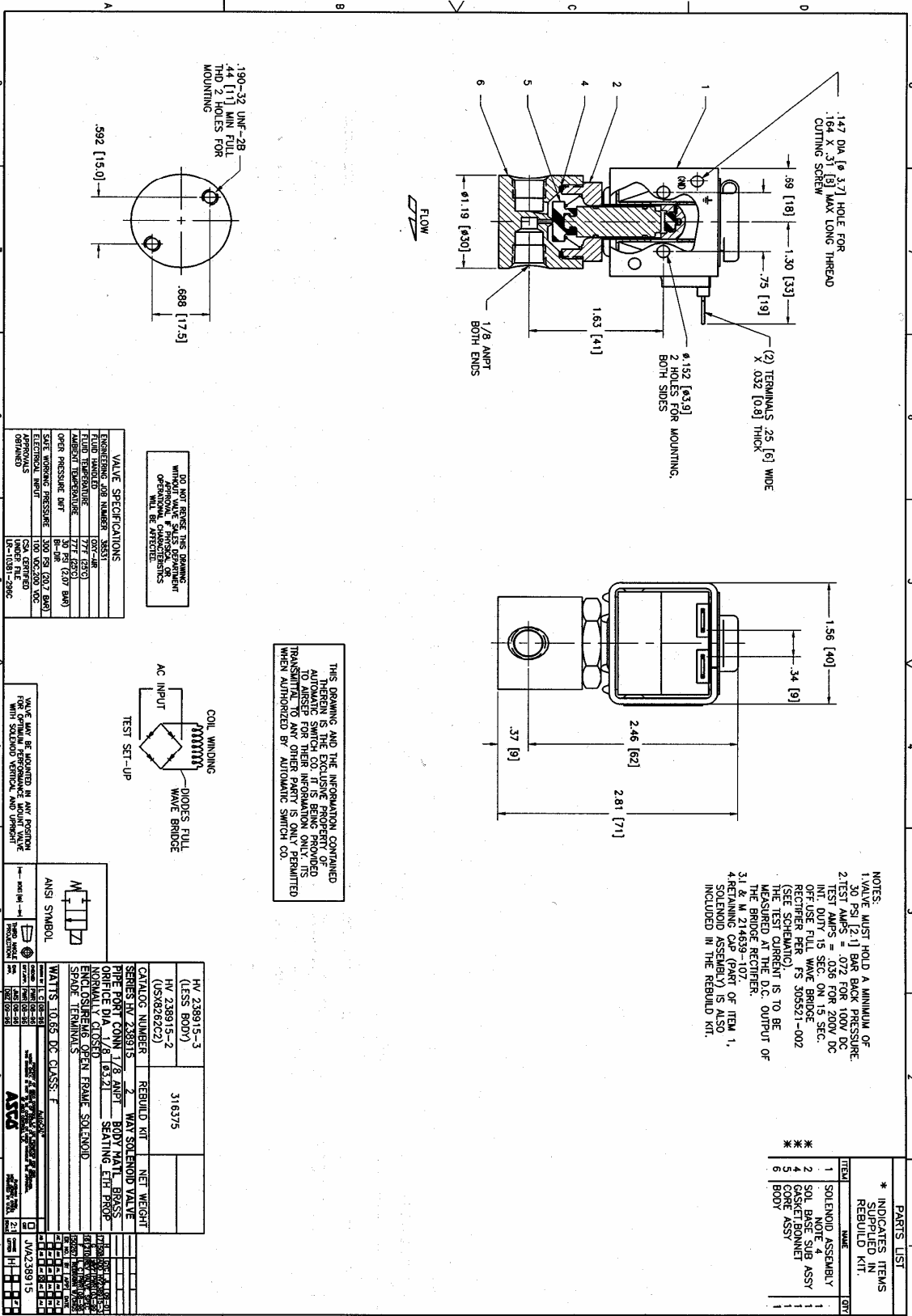

NOTES:  
 1. VALVE MUST HOLD A MINIMUM OF 30 PSI [2.1 BAR] BACK PRESSURE.  
 2. TEST AMPS = .072 FOR 100V DC INFL DUTY 15 SEC ON 15 SEC OFF. USE FULL WAVE BRIDGE RECTIFIER PER FS 305521-002 (SEE SCHEMATIC).  
 THE TEST CURRENT IS TO BE MEASURED AT THE D.C. OUTPUT OF THE BRIDGE RECTIFIER.  
 3. 1/4" DIA. BRIDGE RECTIFIER.  
 4. RETAINING CAP (PART OF ITEM 1, SOLENOID ASSEMBLY) IS ALSO INCLUDED IN THE REBUILD KIT.

| PARTS LIST                                 |                    |     |
|--|--------------------|-----|
| ITEM                                       | NAME               | QTY |
| * INDICATES ITEMS INCLUDED IN REBUILD KIT. |                    |     |
| 1  | SOLENOID ASSEMBLY  | 1   |
| 2  | SOL. BASE SUB ASSY | 1   |
| 3  | GASKET/BONNET      | 1   |
| 4  | CORE               | 1   |
| 5  | CORE ASSY          | 1   |
| 6  | BODY               | 1   |

THIS DRAWING AND THE INFORMATION CONTAINED HEREIN IS THE EXCLUSIVE PROPERTY OF AIRSEP CORPORATION. IT IS TO BE USED ONLY FOR THE PURPOSES AUTHORIZED BY AIRSEP CORPORATION. ANY REPRODUCTION OR TRANSMISSION TO ANY OTHER PARTY IS ONLY PERMITTED WHEN AUTHORIZED BY AUTOMATIC SWITCH CO.

DO NOT REMOVE THIS DRAWING WITHOUT THE WRITTEN PERMISSION OF AIRSEP CORPORATION. ANY REPRODUCTION OR TRANSMISSION TO ANY OTHER PARTY IS ONLY PERMITTED WHEN AUTHORIZED BY AUTOMATIC SWITCH CO.

| VALVE SPECIFICATIONS   |                    |
|------------------------|--------------------|
| ENGINEERING JOB NUMBER | 8837               |
| DESIGNER               | WJW                |
| FLUID TEMPERATURE      | 77°F (25°C)        |
| AMBIENT TEMPERATURE    | 77°F (25°C)        |
| OPER. PRESSURE DIFF.   | 90 PSI (6.20 BAR)  |
| OPER. PRESSURE         | 90 PSI (6.20 BAR)  |
| SAFE WORKING PRESSURE  | 300 PSI (20.7 BAR) |
| ELECTRICAL INPUT       | 100 VAC/200 VDC    |
| APPROVALS              | CSA CERTIFIED      |
| REV.                   | 18-11031-298C      |

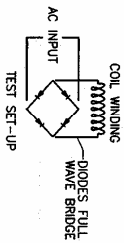

VALVE MUST BE MOUNTED IN VERT. POSITION FOR OPTIMUM PERFORMANCE. MOUNT VALVE WITH SOLENOID VERTICAL AND UPRIGHT.

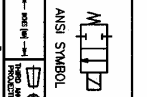

| WARRANTY TO SET CLASS   | REBUILD KIT | NET WEIGHT         |
|-------------------------|-------------|--------------------|
| HV 238915-3 (LESS BODY) | 316375      |                    |
| HV 238915-2 (USA28202)  |             |                    |
| CATALOG NUMBER          | 2           | WAY SOLENOID VALVE |
| PIPE FRONT CONN         | 1/8 ANPT    | BODY MATE. BRASS   |
| MIN. LINE DIA.          | 1.63 [41.2] | SEATING ETH. FIBER |
| ENCLOSURE               | OPEN FRAME  | SOLENOID           |
| SPADE TERMINALS         |             |                    |





**GB** **CE**  
**GENERAL INSTALLATION AND MAINTENANCE INSTRUCTIONS**

**Note:** These General Installation and Maintenance Instructions must be read in conjunction with the Instruction Sheet for the specific product.

**INSTALLATION**

ASCO/JOUCOMATIC components are intended to be used only within the technical characteristics as specified on the nameplate. Changes to the equipment are only allowed after consulting the manufacturer or its representative. Before installation depressurize the piping system and clean internally. The equipment may be mounted in any position if not otherwise indicated on the product by means of an arrow. The flow direction and pipe connection of valves are indicated on the body.

The pipe connections have to be in accordance with the size indicated on the nameplate and fitted accordingly.

- Caution:**
- Reducing the connections may cause improper operation or malfunctioning.
  - For the protection of the equipment install a strainer or filter suitable for the service involved in the inlet side as close to the product as possible.
  - If soap, paste, spray or a similar lubricant is used when tightening, avoid particles entering the system.
  - Use proper tools and locate wrenches as close as possible to the connection point.
  - To avoid damage to the equipment, DO NOT OVERTIGHTEN pipe connections.
  - Do not use valve or solenoid as a lever.
  - The pipe connections should not apply any force, torque or strain to the product.

**ELECTRICAL CONNECTION**

In case of electrical connections, they are only to be made by trained personnel and have to be in accordance with the local regulations and standards.

- Caution:**
- Turn off electrical power supply and de-energize the electrical circuit and voltage carrying parts before starting work.
  - All electrical screw terminals must be properly tightened according to the standards before putting into service.
  - Dependent upon the voltage electrical components must be provided with an earth connection and satisfy local regulations and standards.

- The equipment can have one of the following electrical terminals:
- Spade plug connectors according to ISO-4400 or 3 x DIN-46244 (when correctly installed this connection provides IP-55 protection).
  - Embedded screw terminals in metal enclosure with "Pg" cable gland.
  - Spade terminals (AMP type).
  - Flying leads or cables.

**PUTTING INTO SERVICE**

Before pressurizing the system, first carry-out an electrical test. In case of solenoid valves, energize the coil a few times and notice a metal click signifying the solenoid operation.

**SERVICE**

Most of the solenoid valves are equipped with coils for continuous duty service. To prevent the possibility of personal or property damage do not touch the solenoid which can become hot under normal operation conditions.

**SOUND EMISSION**

The emission of sound depends on the application, medium and nature of the equipment used. The exact determination of the sound level can only be carried out by the user having the valve installed in his system.

**MAINTENANCE**

Maintenance of ASCO/JOUCOMATIC products is dependent on service conditions. Periodic cleaning is recommended, the timing of which will depend on the media and service conditions. During servicing, components should be examined for excessive wear. A complete set of internal parts is available as a spare parts or rebuild kit. If a problem occurs during installation/maintenance or in case of doubt please contact ASCO/JOUCOMATIC or authorized representative.

A separate Declaration of Incorporation relating to EEC Directive 89/32/EEC Annex II B is available on request. Please provide product identification number and serial numbers of products concerned.

The product complies with the essential requirements of the EMC Directive 89/32/EEC and amendments and the Low Voltage Directive 73/23/EEC and 93/68/EEC. A separate Declaration of Conformity is available on request. Please provide product identification number and serial numbers of the products concerned.

**ASCO**  
 50 Hanover Road  
 Florham Park, New Jersey 07932  
 Tel. (973) 966-2000  
 Fax (973) 966-2928

**ASCO**  
 1561 Columbia Highway  
 Aiken, South Carolina 29801  
 Tel. (803) 641-9200  
 Fax (803) 641-9290

**FR** **CE**  
**INSTRUCTIONS GÉNÉRALES D'INSTALLATION ET D'ENTRETIEN**

**Note :** Ces instructions générales d'installation et d'entretien complètent la notice spécifique du produit.

**MONTAGE**

Les composants ASCO/JOUCOMATIC sont conçus pour les domaines de fonctionnement indiqués sur la plaque signalétique ou la documentation. Aucune modification ne peut être réalisée sur le matériel sans l'accord préalable du fabricant ou de son représentant. Avant de procéder au montage, dépressuriser les canalisations et effectuer un nettoyage interne. A moins qu'une flèche ou la notice n'indique un sens de montage spécifique de la tête magnétique, le produit peut être monté dans n'importe quelle position. Le sens de circulation du fluide est indiqué par repères sur le corps et dans la documentation.

La dimension des tuyauteries doit correspondre au raccordement indiqué sur le corps, l'étiquette ou la notice.

**Attention :**

- Une restriction des tuyauteries peut entraîner des dysfonctionnements.
- Afin de protéger le matériel, installer une crépine ou un filtre adéquat en amont, aussi près que possible du produit.
- En cas d'utilisation de rouille, pâte, adhésif ou autre lubrifiant lors du serrage, veiller à ce qu'aucun corps étranger ne pénètre dans le circuit.
- Utiliser un outillage approprié et placer les clés aussi près que possible du point de raccordement.
- Afin d'éviter toute détérioration, NE PAS TROP SERRER les raccords des tuyauteries.
- Ne pas se servir de la vanne ou de la tête magnétique comme d'un levier.
- Les tubes de raccordement ne devront exercer aucun effort, couple ou contrainte sur le produit.

**RACCORDEMENT ÉLECTRIQUE**

Le raccordement électrique doit être réalisé par un personnel qualifié et selon les normes et règlements locaux.

**Attention :**

- Avant toute intervention, couper l'alimentation électrique pour mettre hors tension les composants.
- Toutes les bornes à vis doivent être serrées correctement avant la mise en service.
- Selon la tension, les composants électriques doivent être mis à la terre conformément aux normes et règlements locaux.

Selon les cas, le raccordement électrique s'effectue par :

- Connecteur débrochable ISO-4400 ou 3 x DIN-46244 avec degré de protection IP55 lorsque le raccordement est correctement effectué.
- Bornes à vis solitaires du bobinage, sous boîtier métallique avec presse-étoupe "Pg -".
- Cosses (type AMP).
- Fils ou câbles solitaires de la bobine.

**MISE EN SERVICE**

Avant de mettre le circuit sous pression, effectuer un essai électrique. Dans le cas d'une électrovanne, mettre la bobine sous tension plusieurs fois et écouter le "clic" métallique qui signale le fonctionnement de la tête magnétique.

**FONCTIONNEMENT**

La plupart des électrovannes comportent des bobinages prévus pour mise sous tension permanente. Pour éviter toute brûlure, ne pas toucher la tête magnétique qui, au fonctionnement normal et en permanence sous tension, peut atteindre une température élevée.

**BRUIT DE FONCTIONNEMENT**

Le bruit de fonctionnement varie selon l'utilisation, le fluide et le type de matériel employé. L'utilisateur ne pourra déterminer avec précision le niveau sonore émis qu'après avoir monté le composant sur l'installation.

**ENTRETIEN**

L'entretien nécessaire aux produits ASCO/JOUCOMATIC varie avec leurs conditions d'utilisation. Il est souhaitable de procéder à un nettoyage périodique dont l'intervalle varie suivant la nature du fluide, les conditions de fonctionnement et le milieu ambiant. Lors de l'intervention, les composants doivent être examinés pour détecter toute usure excessive. Un ensemble de pièces internes est proposé en pièces de rechange pour procéder à la réparation. En cas de problème lors du montage/entretien ou en cas de doute, veuillez contacter ASCO/JOUCOMATIC ou ses représentants officiels.

Conformément à la directive CEE 89/32/CEE Annexe II B, une Déclaration d'Incorporation peut être fournie sur demande. Veuillez nous indiquer le numéro d'accusé de réception (AR) et les références ou codes des produits concernés.

Ce produit est conforme aux prescriptions les plus importantes de la directive CEM 89/32/CEE et amendements et aux directives basse tension 73/23/CEE et 94/9/CEE. Une déclaration de conformité peut être fournie sur simple demande. Veuillez nous indiquer le numéro d'accusé de réception (AR) ainsi que les numéros de série des produits concernés.

**ASCO SCIENTIFIC**  
 50 Hanover Road  
 Florham Park, New Jersey 07932  
 Tel. (973) 236-4160  
 Fax (973) 966-6461



**DE** **CE**  
**ALLGEMEINE BETRIEBSANLEITUNG**

**ACHTUNG:** Diese Allgemeine Betriebsanleitung gilt in Zusammenhang mit der jeweiligen Betriebsanleitung für die speziellen Produkte.

**EINBAU**

Die ASCO/JOUCOMATIC-Komponenten dürfen nur innerhalb der auf den Typenschildern angegebenen Daten eingesetzt werden. Veränderungen an den Produkten sind nur nach Rücksprache mit ASCO/JOUCOMATIC zulässig. Vor dem Einbau der Ventile muß das Rohrleitungssystem drucklos geschaltet und innen gereinigt werden. Die Einbaulage der Produkte ist generell beliebig. Ausnahme: Die mit einem Pfeil gekennzeichneten Produkte müssen entsprechend der Pfeilrichtung montiert werden. Die Durchflußrichtung und der Eingang von Ventilen sind gekennzeichnet.

Die Rohranschlüsse sollten entsprechend den Größenangaben auf den Typenschildern mit handelsüblichen Verschraubungen durchgeführt werden. Dabei ist folgendes zu beachten:

- Eine Reduzierung der Anschlüsse kann zu Laststüß- und Funktionsminderungen führen.
- Zum Schutz der Ventile sollen Schutzröhren oder Filter so dicht wie möglich in den Ventillängung integriert werden.
- Bei Abdichtung am Gewinde ist darauf zu achten, daß kein Dichtungsmittel in die Rohrleitung oder das Ventil gelangt.
- Zur Montage darf nur geeignetes Werkzeug verwendet werden.
- Konische Verschraubungen sind sorgfältig anzuziehen. Es ist darauf zu achten, daß beim Anziehen das Gehäuse nicht beschädigt wird.
- Spule und Führungsrohr von Ventilen dürfen nicht als Gegenhalter benutzt werden.
- Die Rohrleitungsanschlüsse sollen fluchten und dürfen keine Spannungen auf das Ventil übertragen.

**ELEKTRISCHER ANSCHLUß**

Der elektrische Anschluß ist von Fachpersonal entsprechend den geltenden VDE- und OES-Richtlinien auszuführen. Es ist besonders auf folgendes zu achten:

- Vor Beginn der Arbeiten ist sicherzustellen, daß alle elektrischen Leitungen und Netzteile spannungslos geschaltet sind.
- Alle Anschlußklemmen sind nach Beendigung der Arbeiten vorsichtsmäßig entsprechend den geltenden Regeln anzuziehen.
- Je nach Spannungsbereich muß das Ventil nach den geltenden Regeln einen Schutzleiteranschluß erhalten.

Der Magnetantrieb kann je nach Bauart folgende Anschlüsse haben:

- Anschluß für Gerüststeckdose nach DIN 43950 Form A/ISO 4400 oder 3x DIN 46244 (durch ordnungsgemäße Montage der Gerüststeckdose wird Schutzklasse IP 55 erreicht).
- Anschlüsse innerhalb eines Blechgehäuses mittels Schraubklemmen. Kabelöffnung in Gehäuse mit PG-Verschraubung.
- Offene Spulen mit Flachstecker (AMP-Fahrer) oder mit eingegossenen Kabelenden.

**INBETRIEBNAHME**

Vor Druckbeaufschlagung des Produktes sollte eine elektrische Funktionsprüfung erfolgen: Bei Ventilen Spannung an der Magnetspule mehrmals ein- und ausschalten. Es muß ein Klicken zu hören sein.

**BETRIEB**

Die meisten Ventile sind mit Spulen für Dauerbetrieb ausgestattet. Zur Vermeidung von Personen- und Sachschäden sollte jede Berührung mit dem Ventil vermieden werden, da die Magnetspule bei längerem Betrieb sehr heiß werden kann.

**GERÄUSCHEMISSION**

Diese hängt sehr stark vom Anwendungsfall, den Betriebsdaten und dem Medium, mit dem das Produkt beaufschlagt wird, ab. Eine Aussage über die Geräuschemission des Produktes muß deshalb von demjenigen getroffen werden, der das Produkt innerhalb einer Maschine in Betrieb nimmt.

**WARTUNG**

Die Wartung hängt von den Einsatzbedingungen ab. In entsprechenden Zeitabständen muß das Produkt geöffnet und gereinigt werden. Für die Überholung von ASCO/JOUCOMATIC-Produkten können Ersatzteile geliefert werden. Treten Schwierigkeiten bei Einbau, Betrieb oder Wartung auf, sowie bei Unklarheiten, so mit ASCO/JOUCOMATIC Rücksprache zu halten.

(ASCO/JOUCOMATIC-Produkte sind entsprechend der EG-Richtlinie 89/32/EWG gefertigt.)

Eine separate Herstellererklärung im Sinne der Richtlinie 89/32/EWG Anhang III ist auf Anfrage erhältlich. Geben Sie bitte für die Produkte die Nummer der Auftragsbestätigung und die Seriennummer an.

Dieses Produkt entspricht den grundlegenden Bestimmungen der EMV-Richtlinie 89/32/EWG, einsch. Nachträge, sowie den Niederspannungsrichtlinien 73/23/EWG u. 93/68/EWG. Bitte geben Sie die Auftragsbestätigungsnummer und die Seriennummer der betreffenden Produkte an.



## INSTRUCCIONES GENERALES DE INSTALACION Y MANTENIMIENTO

Nota: Estas instrucciones Generales de Instalación y Mantenimiento deben considerarse en conjunción con la Hoja de Instrucciones de cada producto.

### INSTALACION

Los componentes ASCO/JOUCOMATIC sólo deben utilizarse dentro de las especificaciones técnicas que se especifican en su placa de características catálogo. Los cambios en el equipo sólo estarán permitidos después de consultar al fabricante o a su representante. Antes de la instalación despresurice el sistema de tuberías y límpielo internamente.

El equipo puede utilizarse en cualquier posición si no estuviera indicado lo contrario sobre el mismo mediante una flecha o en el catálogo.

En el cuerpo o en el catálogo se indican el sentido del fluido y la conexión de las válvulas a la tubería.

Las conexiones a la tubería deben corresponder al tamaño indicado en la placa de características la etiqueta o el catálogo y ajustarse adecuadamente.

- La reducción de las conexiones puede causar operaciones incorrectas o defectos de funcionamiento.
- Para la protección del equipo se debe instalar, en la parte de la entrada y tan cerca como sea posible del producto, un filtro adecuado.
- Si se utiliza cinta, pasta, spray u otros lubricantes en el ajuste, se debe evitar que entren partículas en el producto.
- Se debe utilizar las herramientas adecuadas y colocar llaves inglesas lo más cerca posible del punto de conexión.
- Para evitar daños al equipo, NO FORZAR las conexiones a la tubería.
- No utilizar la válvula o el solenoide como palanca.
- Las conexiones a la tubería no producirán ninguna fuerza, por tensión sobre el producto.

### CONEXION ELECTRICA

Las conexiones eléctricas serán realizadas por personal cualificado y deberán adaptarse a las normas y regulaciones locales.

#### Precaución:

- Antes de comenzar el trabajo, desconecte el suministro de energía eléctrica y desenergice el circuito eléctrico y los elementos portadores de tensión.
- Todos los terminales eléctricos deben estar apretados adecuadamente según normas antes de su puesta en servicio.
- Según el voltaje, los componentes eléctricos deben disponer de una conexión a tierra y satisfacer las normas y regulaciones locales.

- El equipo puede tener uno de los siguientes terminales eléctricos:
- Conexiones desenchufables según ISO 4400 o 3 x DIN-46244 (cuando se instala correctamente esta conexión proporciona una protección IP-65).
  - Terminales de tornillo con carcasa metálica con entrada de cable de conexión rosca "PG".
  - Conector desenchufable (tipo AMP).
  - Salida de cables.

### PUESTA EN MARCHA

Se debe efectuar una prueba eléctrica antes de someter a presión el sistema. En el caso de las válvulas solenoides, se debe energizar varias veces la bobina y comprobar que se produce un sonido mecánico que indica el funcionamiento del solenoide.

### SERVICIO

La mayor parte de las válvulas solenoides se suministran con bobinas para un servicio continuo. Con el fin de evitar la posibilidad de daños personales o materiales no se debe tocar el solenoide, ya que puede haberse calentado en condiciones normales de trabajo.

### EMISION DE RUIDOS

La emisión de ruidos depende de la aplicación, medio y naturaleza del equipo utilizado. Una determinación exacta del nivel de ruido sólo puede llevar a cabo por el usuario que disponga la válvula instalada en su sistema.

### MANTENIMIENTO

El mantenimiento de los productos ASCO/JOUCOMATIC depende de las condiciones de servicio. Se recomienda una limpieza periódica, dependiendo de las condiciones de medio y del servicio. Durante el servicio, los componentes deben ser examinados por si hubieran desgastado excesivo. Se dispone de un juego completo de partes internas como recambio o kit de montaje. Si ocurre un problema durante la instalación/mantenimiento o en caso de duda contactar con ASCO/JOUCOMATIC o representantes autorizados.

Se dispone, por separado y bajo demanda, de una Declaración de incorporación conforme a la Directiva EEC 89/392/EEC Anexo II B. Rogamos que nos faciliten los códigos y números de aceptación de pedido correspondientes.

Este producto es conforme a las principales prescripciones de la directiva CEM 89/336/EEC y a las enmiendas y directivas baja tensión 73/23/CEE y 94/94/CEE. Si lo desea, podemos facilitarle una Declaración de Conformidad por separado. Rogamos faciliten el número de confirmación de pedido y los números de serie de los respectivo productos.

ASCOMATICA S.A. de C.V.  
Bosque de Durango No. 65-1003A  
Fraccionamiento Bosques de las Lomas  
Delegación Miguel Hidalgo  
México, D.F. CP11700  
Tel: (52)-55-5396-7741  
Fax: (52)-55-5396-7719

ASCO Valve Canada  
P.O. Box 160 (Airport Road)  
Bramford, Ontario N7S 5M8  
Tel: (519) 758-2700  
Fax: (519) 758-5940

ASCOTECH S.A. de C.V.  
Circuito Del Progreso No.27  
Parque Industrial Progreso  
Mexico, B.C. Mexico  
Tel: (011)-52-686-359-8500  
Fax: (011)-52-686-359-8548



## ISTRUZIONI DI INSTALLAZIONE E DI MANUTENZIONE GENERALE

Nota: Queste istruzioni devono essere lette in congiunzione con il manuale specifico del prodotto.

### INSTALLAZIONE

La elettrovalvole devono essere utilizzate esclusivamente rispettando le caratteristiche tecniche specificate sulla targhetta. Variazioni sulle valvole o sui piloti sono possibili solo dopo aver consultato il costruttore o i suoi rappresentanti. Prima dell'installazione despressurizzare i tubi e pulire internamente. La elettrovalvole possono essere montate in tutte le posizioni. Diversamente, una freccia posta sulla valvole indica che deve essere montata in posizione verticale e dritta. La direzione del flusso è indicata sul corpo della valvole per mezzo di una freccia oppure con l'etichetta "IN", "1", "A", o "P".

I raccordi devono essere conformi alla misura indicata sulla targhetta apposta.

#### Attenzione:

- Ridurre i raccordi può causare operazioni sballigliate o malfunzionamento.
- Per proteggere il componente installare il più vicino possibile al lato ingresso, un filtro adatto al servizio.
- Se si usano nastro, pasta, spray o lubrificanti simili durante il serraggio, evitare che delle particelle entrino nel corpo della valvola.
- Usare un'attrezzatura appropriata e utilizzare le chiavi solo sul corpo della valvola.
- Per evitare danni al corpo della valvola, NON SERRARE ECCESSIVAMENTE I TUBI.
- Non usare la valvola o il pilota come una leva.
- I raccordi non devono esercitare pressione, torsione o sollecitazione sull'elettrovalvola.

### ALLACCIAMENTO ELETTRICO

L'allacciamento elettrico deve essere effettuato esclusivamente dal personale specializzato e deve essere conforme alle Norme locali.

#### Attenzione:

- Prima di mettere in funzione togliere l'alimentazione elettrica, disconnettere il circuito elettrico e la parti sotto tensione.
- I morsetti elettrici devono essere correttamente avvitati, secondo le Norme, prima della messa in servizio.
- Le elettrovalvole devono essere provviste di morsetti di terra a seconda della tensione e delle Norme di sicurezza locali.

- I piloti possono avere una delle seguenti caratteristiche elettriche:
- Connettere ISO-4400 o 3 x DIN-46244 (se installato correttamente è IP-65).
  - Morsetteria racchiusa in custodia metallica. Entrata cavi con pressacavi tipo "PG".
  - Bobine con attacchi FASTON (tipo AMP).
  - Bobine con fili o cavo.

### MESSA IN FUNZIONE

Prima di dare pressione alla valvola, assicurarsi un test elettrico. Etcitare la bobina diverse volte fino a notare un suono meccanico che dimostra il funzionamento del pilota.

### SERVIZIO

Molte elettrovalvole sono provviste di bobine per funzionamento continuo. Per prevenire la possibilità di danneggiare cose o persone, non toccare il pilota. La custodia della bobina e del pilota può scaldarsi anche in normali condizioni di funzionamento.

### EMISIONI SUONI

L'emissione di suoni dipende dall'applicazione e dal tipo di elettrovalvole. L'utente può stabilire esattamente il livello del suono solo dopo aver installato la valvola sul suo impianto.

### MANUTENZIONE

Generalmente questi componenti non necessitano spesso di manutenzione. Comunque, in alcuni casi è necessario fare attenzione a depositi o ad eccessivi usura. Questi componenti devono essere puliti periodicamente, il tempo che intercorre tra una pulizia e l'altra varia a seconda delle condizioni di funzionamento. Il ciclo di durata dei componenti dipende dalle condizioni di funzionamento. In caso di usura è disponibile un set completo di parti interne per per la revisione. Se si incontrano problemi durante l'installazione e la manutenzione o se si hanno dei dubbi, consultare ASCO/JOUCOMATIC o i suoi rappresentanti.

L'utente può richiedere al costruttore una dichiarazione separata riguardante le Direttive EEC 89/392/EEC e 91/598/EEC (vedere allegato II B) fornendo il numero di serie e il riferimento dell'ordine relativo.

Questo prodotto soddisfa i requisiti essenziali della direttiva CEM 89/336/CEE nonché gli emendamenti e le direttive sulle basse tensioni 73/23/CEE e 94/94/CEE. Una Dichiarazione di Conformità separata può essere ottenuta su richiesta. Si prega di fornire il numero della conferma dell'ordinativo ed i numeri di serie dei relativi prodotti.



## ALGEMENE INSTALLATIE- EN ONDERHOUDSINSTRUKTIE

N.B.: Deze algemene instructies Le.v. installeer en onderhoud moeten in acht worden genomen, tezamen met de specifieke voorschriften van het product.

### INSTALLATIE

ASCO/JOUCOMATIC producten mogen uitsluitend toegepast worden binnen de op de naamplaat aangegeven specificaties. Wijzigingen, zowel omtrent als mechanisch, zijn alleen toegestaan na overleg met de fabrikant of haar vertegenwoordiger. Voor het bouwen dient het leidingstelsel drukloos gemaakt te worden en inwendig gereinigd.

De positie van de afsluiter is naar keuze te bepalen, behalve in die gevallen waarbij het tegengedw. door pijlen wordt aangegeven. De doortroomrichting wordt bij afsluiters aangegeven op het afsluiterhuis.

De pijp aansluiting moet overeenkomstig de naamplaatgegevens plaatsvinden.

#### Hierbij moet men letten op:

- Een reductie van de aansluitingen kan tot prestatie- en funktie-stoornissen leiden.
- Ter bescherming van de interne delen moet een filter in het leidingstelsel aanwezig zijn.
- Bi het gebruik van draadafsluiterkoppelingen of tape mogen er geen deeltjes in het leidingwerk geraken.
- Men dient uitsluitend geschikt gereedschap voor de montage te gebruiken.
- Bi konische/afsp. koppelingen moet met een zodanig koppel worden gewerkt dat het product niet wordt beschadigd.
- Het product, de behuizing of de spoel mag niet als hefboom worden gebruikt.
- De pijp aansluitingen mogen geen krachten of momenten op het product overdragen.

### ELEKTRISCHE AANSLUITING

In geval van elektrische aansluiting dient dit door vaardig personeel te worden uitgevoerd volgens de door de plaatselijke overheid bepaalde richtlijnen.

#### Men dient in het bijzonder te letten op:

- Voor dat men aan het werk begint moeten alle spanningsvoerende delen spanningsloos worden gemaakt.
- Alle aansluitingen moeten aan het beveling van het werk volgens de juiste normen worden aangebracht.
- Al naar gelang het spanningsbereik, moet het product volgens de geldende normen van een aarding worden voorzien.

Het product kan de volgende aansluitingen hebben:

- Stokeraansluiting volgens ISO-4400 of 3x DIN-46244 (bij juiste montage wordt de dichtheidsklasse IP-65 verkregen).
- Aansluiting binnen in het metaal huis d.m.v. schroefaansluiting. De kabeldoorvoer heeft een "PG" aansluiting.
- Spoelen met platte stekers (AMP type).
- Lussen of aangegeven kabels.

### IN GEBRUIK STELLEN

Voor dat de druk aangevoerd wordt dient een elektrische test te worden uitgevoerd, ingeval van magnetische afsluiters, legt men meerdere maten spanning op de spoel aan waarbij een duidelijk "klikken" hoorbaar moet zijn bij juist functioneren.

### GEBRUIK

De meeste magnetische afsluiters zijn uitgevoerd met spoelen voor continu gebruik. Omdat persoonslijfe of zakelijke schade kan ontstaan bij overspanning dient men dit te vermijden, daar bij langdurige inachtneming de spoel of het afsluiterhuis kan worden.

### GELUIDSEMISIE

Dit hangt sterk af van de toepassing en het gebruikte medium. De bepaling van het geluidsniveau kan pas uitgevoerd worden nadat het ventiel is ingebouwd.

### ONDERHOUD

Het onderhoud aan de afsluiters is afhankelijk van de bedrijfsomstandigheden. In bepaalde gevallen moet men bedacht zijn op media welke sterke vervuiling binnen in het product kunnen veroorzaken. Men dient dan regelmatig inspecties uit te voeren door de afsluiter te openen en te reinigen. Indien ongewone slijtage optreedt dan zijn reserve onderdelen beschikbaar om een inwendige revisie uit te voeren. Ingeval problemen of onduidelijkheden tijdens montage, gebruik of onderhoud optreden dan dient men zich tot ASCO of haar vertegenwoordiger te wenden.

Een aparte fabrikanter verklaring van Inbouw, in de zin van EU-richtlijn 89/392/EEC aanhangende II B kan door de afnemer na opgave van orderbevestigingsnummer en serie nummer verkregen worden.

Dit product voldoet aan de essentiële vereisten van de EMC Richtlijn 89/336/EEC en amendementen, net als aan de richtlijnen 73/23/EEC en 94/94/EEC inzake laagspanning. Een afzonderlijke verklaring van overeenstemming is op verzoek verkrijgbaar. Vermeld n.a.v. het nummer van de opdrachtbevestiging en de serienummers van de betreffende producten.

ASCO® MML All Rights Reserved. Form No. 6950B5

50 Hanover Road, Florham Park, New Jersey 07932 Page 2 of 2  
www.ascovalve.com Printed in U.S.A.