

# Ozone Systems

---

## Installation & Operation Manual

### **M-15/O2, P-20/O2 CD15/O2, CD20/O2**

High Dissolved Ozone Generation System



**Tested and certified by  
WQA to NSF/ANSI 50 as a  
component only.**

**ClearWater Tech, LLC.**  
Integrated Ozone Systems

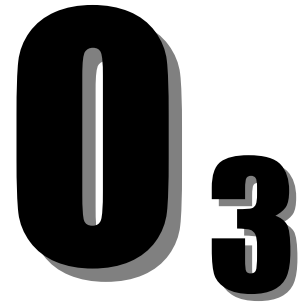

## **INTRODUCTION**

---

This Installation and Operation Manual is written to assist in the installation, operation and maintenance of ozone delivery systems manufactured by ClearWater Tech, LLC. This equipment has been designed using the most modern materials and technology available.

Please read this manual carefully and in its entirety before proceeding with any installation, operation or maintenance procedure associated with this equipment. Failure to follow these instructions could result in personal injury, damage to the equipment or reduced product performance.

In an ongoing effort to improve reliability and operating efficiency, ClearWater Tech may find it necessary to make changes to its products. Therefore, the information contained in this manual may not conform in every respect to earlier versions of ClearWater Tech ozone system found in the field. If you have any questions, please contact your ClearWater Tech dealer or the ClearWater Tech service department.



# TABLE OF CONTENTS

---

<b>Overview</b> .....	3
<b>Safety Information</b> .....	4
<b>Theory of Operation/Product Description</b> .....	6
<i>Figure 1 – Complete Ozone System</i> .....	6
<i>Figure 2 – Injector Manifold</i> .....	8
<b>Installation Procedures – Getting Started</b> .....	9
<b>Installation Procedures – Plumbing</b> .....	10
<i>Figure 3 – Sidestream Plumbing Installation Diagram</i> .....	12
<i>Figure 4 – Full Flow Plumbing Installation Diagram</i> .....	12
<i>Figure 5 – Contact Column Installation Diagram</i> .....	13
<i>Figure 6 – Contact Column Exploded View</i> .....	13
<b>Installation Procedures – Electrical</b> .....	14
<i>Figure 7 – Interlock Box Terminal Strip Connections</i> .....	15
<b>Installation Procedures – Pneumatic</b> .....	17
<i>Figure 8 – Hook-Ups: Ozone Generator To Vacuum Break &amp; Vacuum Break to         Injector Manifold</i> .....	17
<i>Figure 9 – Vacuum Break Detail</i> .....	18
<i>Figure 10 – Ozone Destruct System Detail</i> .....	20
<b>Start-Up and Calibration</b> .....	21
<i>Figure 11 – Pneumatic Operating Parameters</i> .....	23
<i>Figure 12 – M-15/O<sub>2</sub> and P-20/O<sub>2</sub> - Ozone Generator Drive Board LED Function</i> ..	24
<i>Figure 13 – M-15/O<sub>2</sub> and P-20/O<sub>2</sub> - Drive Module</i> .....	24
<i>Figure 14 – CD15/O<sub>2</sub> and CD20/O<sub>2</sub> - Ozone Generator Drive Board LED Function</i> .	25
<i>Figure 15 – CD15/O<sub>2</sub> and CD20/O<sub>2</sub> – Drive Board</i> .....	25
<b>Maintenance</b> .....	27
<i>Figure 16 – Ozone Generator Cooling Fan Assembly</i> .....	29
<i>Figure 17 – Reaction Chamber – Exploded View</i> .....	32
<b>Troubleshooting</b> .....	33
<b>Appendix A – Specifications</b> .....	38
<b>Appendix B – Parts List</b> .....	49
<b>Appendix C – Maintenance Kit</b> .....	51
<b>Appendix D – Logic Schematics</b> .....	52
<b>Appendix E – Drive Module Input Voltages</b> .....	57
<b>Appendix F – Warranty Information</b> .....	59

# OVERVIEW

## How Ozone In Generated

Ozone is generated by exposing oxygen molecules (O<sub>2</sub>) in an air stream to a controlled, high energy electrical field. As the air stream passes through the electrical field produced inside the ozone generator, some oxygen molecules are split, forming single oxygen atoms (O<sub>1</sub>). These oxygen atoms then recombine with other oxygen molecules in the air stream, forming ozone (O<sub>3</sub>)

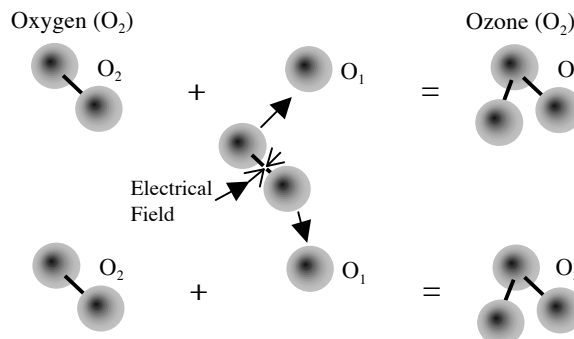

## Properties of Ozone

Ozone is the most powerful oxidizer available that can be safely used in water treatment<sup>1</sup>. It is used to treat drinking water, bottled water, swimming pool water, waste water, food and beverage processing water, and in many other applications. Ozone is effective in performing the following:

- **Disinfection** – Bacterial disinfection, inactivation of viruses and cysts.
- **Oxidation of Inorganics** – Precipitates, iron, manganese, sulfides nitrides and organically-bound heavy metals
- **Oxidation of Organics** – Including organics causing color, taste, and odor problems. Some detergents and pesticides, phenols, VOCs, turbidity control and micro-floccuity control and micro-flocculation of soluble organics.

Molecular Weight	48
Odor	Readily detectable at concentrations above 0.02 ppm in air
Color	Bluish in ozone generator cell, but ozone/air mixture exiting generator is invisible – even at high ozone concentrations.
Gas Density:	2.144 grams/liter at 32°F (Approximately 150% that of oxygen).
Solubility	Only partially soluble in water, but about 10-20 times more soluble than oxygen (at 68°F).

## Benefits of Ozone Use



- Ozone is generated on site – no transportation or storage is required
- The most powerful oxidizer commercially available – very effective for disinfection and oxidation without handling problems.
- Ozone creates no potentially harmful by-products (such as THMs) – the only by-product is oxygen.
- Ozone leaves no telltale taste or odor.

<sup>1</sup> Water Quality Association, “Ozone for POU, POE and Small Water System Water Treatment Applications,” Lisle, IL, 1999

# Safety Information

---

## Safety Warnings

Two aspects of ClearWater Tech ozone generators represent potential dangers – ozone gas and high voltage electricity.

**OZONE GAS** – WARNING: HIGH CONCENTRATIONS OF OZONE GAS ARE DANGEROUS TO HUMANS. LOW CONCENTRATIONS CAN CAUSE IRRITATION TO THE EYES, THROAT AND RESPIRATORY SYSTEM.

This ClearWater Tech corona discharge ozone generator is designed to operate under a vacuum condition. While safety precautions have been taken, entering the equipment area should be avoided if ozone gas is detected. Ozone has a very distinctive odor and is detectable at very low concentrations (0.02 ppm), which is far below OSHA's maximum permissible exposure level of 0.1 ppm.



**HIGH VOLTAGE** – WARNING: CLEARWATER TECH OZONE GENERATORS OPERATE AT HIGH VOLTAGE. DO NOT TAMPER WITH OR DELIBERATELY BYPASS THE COVER OR SAFETY SWITCHES BUILT INTO THE OZONE GENERATOR UNLESS INSTRUCTED TO DO SO BY THIS MANUAL. IF CONTACT IS MADE WITH OPERATING HIGH VOLTAGE COMPONENTS, ELECTRIC SHOCK WILL OCCUR.

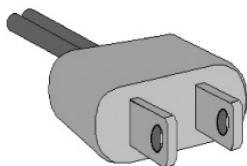

ClearWater Tech corona discharge ozone generators take line voltage and convert it to 48 VDC. A high voltage transformer then boosts the voltage. Proper care must be used by a qualified electrician when making any internal adjustments or performing any maintenance procedures.

## **IMPORTANT SAFETY INSTRUCTIONS**

When installing and using this electrical equipment, basic safety precautions should always be followed, including the following:

### **1. READ AND FOLLOW ALL INSTRUCTIONS.**

### **2. SAVE THESE INSTRUCTIONS.**

3. All electrical connections should be made by a licensed, qualified electrician.
4. Before attempting any electrical connections, be sure all power is off at the main circuit breaker.
5. Install all electrical equipment at least five feet from any open body of water using non-metallic plumbing.
6. Install check valves and a vacuum break to prevent water from contacting the electrical equipment.
7. The electrical supply for this product must include a suitably rated switch or circuit breaker to open all ungrounded supply conductors to comply with Section 422-20 of the National Electrical Code, ANSI/NFPA 70-1987. The disconnecting means must be readily accessible to the operator(s) but installed at least five feet from any open body of water.
8. Be sure to bond (ground) the system using the copper-bonding lug on the bottom of the ozone generator. The system should be bonded with solid copper wire conforming to all local, state and national electrical codes.
9. The system should be sized appropriately for its intended use by a qualified professional familiar with the application. This equipment must be validated by the manufacturer for its intended use; failure to do so may void the warranty.

# Theory of Operation/Product Description

The M-15/O<sub>2</sub>, P-20/O<sub>2</sub>, CD15/O<sub>2</sub>, and CD20/O<sub>2</sub> ozone systems are advanced ozone delivery systems, engineered to efficiently produce high levels of ozone. The M-15/O<sub>2</sub>, P-20/O<sub>2</sub>, CD15/O<sub>2</sub>, and CD20/O<sub>2</sub> system contains an ozone generator, an air preparation unit, an electrical interlock box, and booster pump (optional). Coupled with an ozone injector manifold (sized appropriately for the individual installation and sold separately), this system will take water from a clean water source, re-pressurizes it, and injects ozone to the water. Equipped with an interlock box, the M-15/O<sub>2</sub>, P-20/O<sub>2</sub>, CD15/O<sub>2</sub>, and CD20/O<sub>2</sub> ozone systems are able to be controlled by an ORP controller, ozone monitor, or a variety of other controls. Each complete, integrated system includes the components required for reliable, efficient ozone production and can be divided into four general segments: air preparation system, ozone generator, booster pump (optional), and the system control (interlock box).

## Complete Ozone System

Figure 1

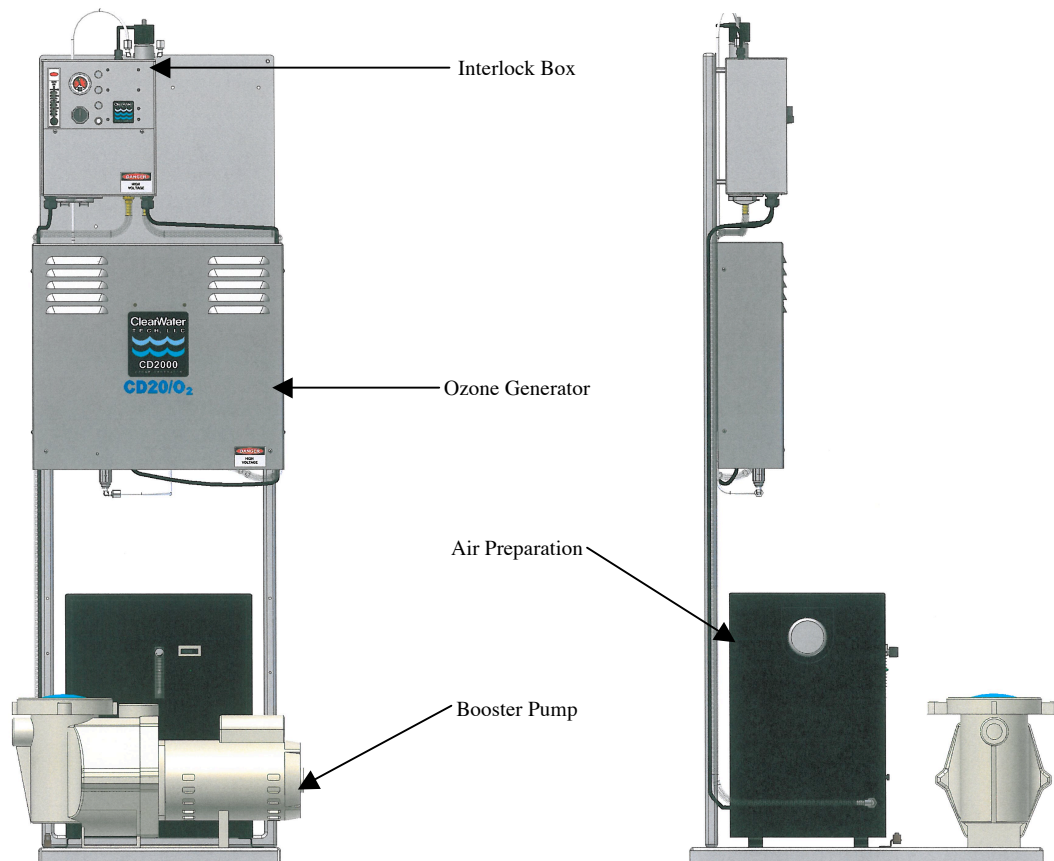

Shown: CD20/O<sub>2</sub>, with Booster Pump

## Air Preparation System

ClearWater Tech pressurized ozone generators require a source of clean, dry, oil-free, oxygen-enriched air for effective ozone production. To meet that need, ClearWater Tech employs pressure swing adsorption (PSA) technology with an oil-less compressor to increase the concentration of oxygen and reduce the moisture content in the feed gas (the air supplied to the ozone generator). This substantially improves the output capability of the ozone generator and prevents premature failure of key internal components. These air preparation systems deliver 90%+/-3% oxygen purity at -60°F dew point and at very low pneumatic pressures, minimizing noise and reducing compressor wear.

## Theory of Operation/Product Description

The air preparation system directly affects how many grams of ozone is produced per hour which in turn the ozone concentration, also known as “percent by weight.” Since ozone is produced with oxygen, the greater the percent of oxygen that enters the ozone generator the greater percent of ozone that will come out of the ozone generator. Using a PSA oxygen concentrator allows the M-15/O<sub>2</sub>, P-20/O<sub>2</sub>, CD15/O<sub>2</sub>, and CD20/O<sub>2</sub> ozone generation systems to produce ozone at a high grams per hour while also maintaining a high percent by weight. The high percent by weight results in a high solubility of the ozone gas in solution to ensure the grams of ozone produced make it into solution resulting in a high dissolved ozone level.

### Ozone Generator

The M-15/O<sub>2</sub> is equipped with a M1500 ozone generator. The P-20/O<sub>2</sub>, is equipped with a P2000 ozone generator. The CD15/O<sub>2</sub>, is equipped with a CD1500 ozone generator. The CD20/O<sub>2</sub> is equipped with a CD2000 ozone generator. The oxygen feed gas produced by the air preparation system is supplied to the ozone generator at a maximum pressure of 5 pounds per square inch (psi). It then flows into the built-in air flow meter; at this point, the feed gas is mostly drawn through the ozone generator by the vacuum created at the ozone injector - rather than by the pressure from the air preparation system compressors. The needle valve in the air flow meter in the interlock box and a need valve in the air flow meter in the air preparation system are used to maintain optimum pneumatic parameters inside the ozone reaction chambers.

The feed gas of the air preparation system enters the fused, thermally-protected reaction chambers inside the ozone generator; some of the oxygen molecules are split while passing through the high voltage electrical field (the “corona”), forming single oxygen atoms (O<sub>1</sub>). These oxygen atoms then recombine with other oxygen molecules in the air stream, forming ozone (O<sub>3</sub>). ClearWater Tech ozone generators are designed to supply high concentrations of ozone gas.

### Control Panel

The M-15/O<sub>2</sub>, P-20/O<sub>2</sub>, CD15/O<sub>2</sub>, and CD20/O<sub>2</sub> systems incorporate a user-friendly interlock box, which includes: ozone generator oxygen flow meter, ozone generator vacuum gauge, control interface for MCI and ORP signals, and vacuum switch for automatic operation.

### Booster Pump (optional)

ClearWater Tech model M-15/O<sub>2</sub>, P-20/O<sub>2</sub>, CD15/O<sub>2</sub>, and CD20/O<sub>2</sub> ozone systems may include a booster pump. A variety of booster pumps are available from ClearWater Tech to match different applications.

### Vacuum Break (optional)

In addition to the check valve at the output of the ozone generator and the check valve at the inlet of the ozone injector, a vacuum break can be used to insure water does not flow back into the ozone generator.

### Ozone Injector Manifold (optional)

The ozone injector serves two purposes: One, it creates the vacuum required to safely draw the ozone gas from the ozone generator and two, it provides a means by which the ozone gas can become dissolved in water. A very dynamic injection process is required to effectively dissolve ozone in water.

ClearWater Tech offers Mazzei® injectors for maximum mass transfer efficiency. The injector

#### A Short Course in Fine Bubbles

**Lesson 1** – The large bubble (20mm) has a volume of 4.19 cm<sup>3</sup> and a surface area of 12.6 cm<sup>2</sup>.

**Lesson 2** – 296small bubbles (3mm) could be made from the large bubble in lesson 1. They would have a total surface area of 83.6cm<sup>2</sup>. This is 6.6 times the surface area of the large bubble.

**Lesson 3** – Theoretically, 6.6 times as muchwater could be ozonated with the same amount of ozone!

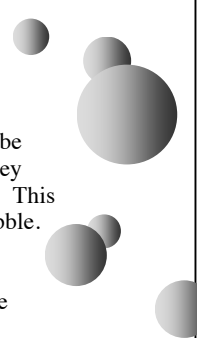

## Theory of Operation/Product Description

produces a cavitation effect, enabling the ozone gas to join the water stream in the form of extremely tiny bubbles. These bubbles must be as small as possible in order to increase the ratio of bubble surface area to the amount of ozone entering the water.

A pressure differential must be maintained across the venturi injector for correct operation. ClearWater Tech stocks a complete line of high-efficient venturi injectors from 4-100 GPM.

### Injector Manifold

Figure 2

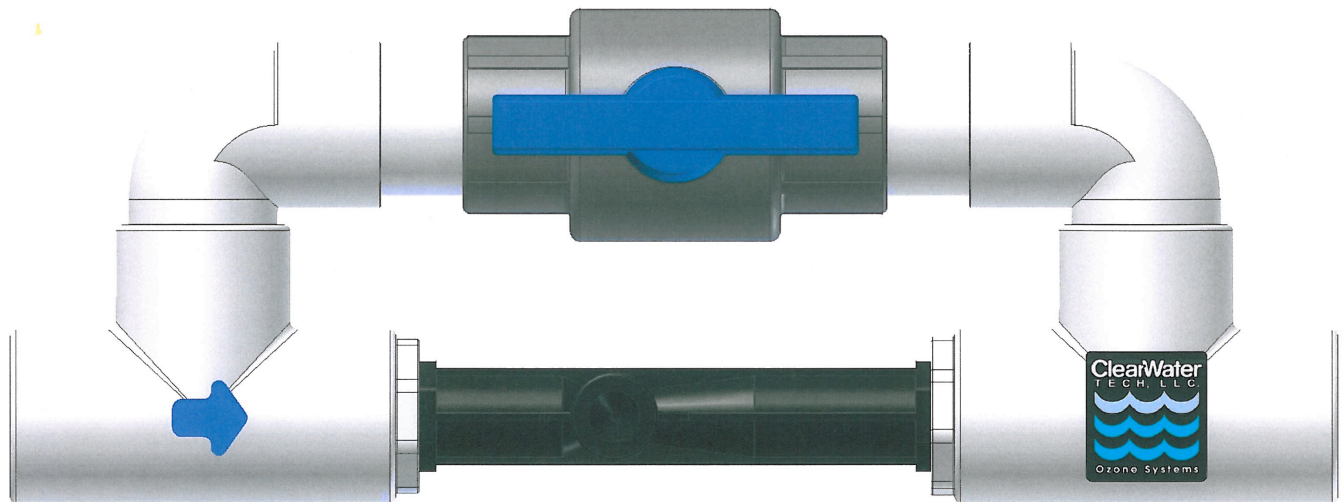

### Contacting Vessel (optional)

To maximize the effectiveness of ozone, it must be thoroughly mixed and have adequate time to react with the contaminants in the water before returning to usage or further processing. The contacting vessel is designed to achieve this necessary mixing and contact time. A variety of contacting vessels are available for different applications from ClearWater Tech.

### Ozone Destruct

The ClearWater Tech off-gas destruct systems (offered separately), consists of two components the ozone destruct unit (a heated chamber filled with manganese dioxide and copper oxide) and a water trap. Used in conjunction with a ClearWater Tech off-gas vent, the ozone destruct system is an effective way to vent the contact vessel when it is impractical to send the off gas to atmosphere or reintroduce it to the water. See the “Ozone Off-Gas Destruct” manual for installation and maintenance procedures.

# Installation Procedures – Getting Started

---

## Unpacking

Compare the ozone system equipment received to the packing list provided. Before beginning any installation procedures, thoroughly inspect all components for damage. If damage is noticed, promptly notify the freight carrier and request an on-site inspection. Inspect all packing materials for small parts before discarding. Inspect all plumbing, fittings and tubing for packing material that may have become lodged in openings.

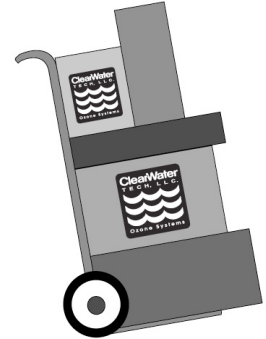

## Equipment Placement

When placing the ozone system on the equipment pad, make sure to consider safety, maintenance requirements, local building and fire codes, etc. The components should be easily accessible by the operators, including equipment access doors and electrical hook-up boxes. All meters, gauges, indicator lights and switches should be visible and accessible. Dimensional drawings of the M-15/O<sub>2</sub>, P-20/O<sub>2</sub>, CD15/O<sub>2</sub>, and CD20/O<sub>2</sub> systems are included in Appendix A.

The air preparation system and ozone generator should be located as close as possible to the point of ozone injection (with in 20 feet is recommended). Ozone is an unstable gas and will begin reverting back to oxygen very quickly. To determine the most favorable ozone injection point, the following items should be considered:

- Located *downstream* of all other existing water system components.
- Located *upstream* of the residual sanitizer injection point (if so equipped).
- In a Side stream plumbing configuration (see Figure 2) with recirculation, the pH adjustment chemical injection point must be located *downstream* of the residual sanitizer injection point (if so equipped).
- In a Full Flow plumbing configuration (see Figure 3) without recirculation, locate *downstream* of the pH adjustment chemical injection point.
- Adequate protection from weather, dust and excessive heat.

Like any electronic component, performance and longevity is enhanced by favorable operating conditions. Also, since each air preparation system and ozone generator is air-cooled, a relatively dust-free, well-ventilated area is required. No caustic chemicals should be stored in the area surrounding the equipment. A minimum clearance of six inches from the vents on either side of the ozone generator is required.

The equipment is heavy and requires proper support. Therefore, a clean, dry, level surface should be provided for the air preparation system and ozone generator. These components should be securely fastened to the surface using the mounting holes and/or tabs provided.

The air preparation system and ozone generator are *not* designed to withstand outdoor elements, including direct contact with water and/or temperature extremes. Therefore, the equipment must be installed in an environment consistent with the following operating parameters:

- Ambient temperature range: 20°F to 95°F continuous. If the temperature around the equipment consistently exceeds 95°F, additional air-cooling must be provided.
- Humidity: 0 - 90% relative humidity, non-condensing environment. **Warning: 0 - 75% relative humidity, non-condensing environment, must be observed for any heat regenerative air dryer.**
- Line voltage: +/-10% of rated input

**Note:** Equipment installed in extreme environmental conditions will void manufacturer's warranty.

Allow room for the peripheral equipment (booster pump, injector manifold, contact vessel, etc.)



# Installation Procedures – Plumbing

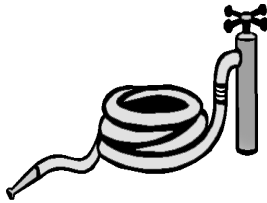

The ozone system should be plumbed using either a side stream or full flow configuration. The side stream loop method takes a *portion* of the water from the main flow (see Figure 2) and diverts it into a side stream *downstream* of the filter (if so equipped). Ozone is introduced into the side stream water and is allowed contact time with the water before it is returned to the main flow at a point downstream of all other equipment (heaters, solar panels, etc., if so equipped) in the circulation system. A

booster pump is usually employed to compensate for the flow restriction caused by the side stream loop and the injector manifold. If a halogen-type residual sanitizer is utilized, its injection point should be as far downstream as possible from the point at which the side stream water returns to the main flow. In a full flow configuration, the same system components are usually involved and appear in the same order with respect to the direction of flow. However, *all* the water in the main flow is allowed contact time with the ozone (see Figure 3). A booster pump may be necessary to maintain proper flow requirements. If employed, the booster pump is located *upstream* of the point at which the ozone injector manifold is installed.

## NOTES:

- Adequate use of unions and isolation valves is strongly recommended to facilitate maintenance and repairs
- Use Schedule 80 PVC for all plumbing connections wherever possible. Plumbing size requirements are dictated by the water flow characteristics of the system.
- Make sure to use proper plumbing practices and secure all plumbing and system equipment according to local codes.
- Ozone is a powerful oxidizer and will degrade certain materials. Use ozone-compatible plumbing materials for section(s) of the system that will come in contact with ozone dissolved in water. The following is a list of the materials that are compatible with ozone:
  - PVC
  - CPVC
  - Kynar
  - Teflon
  - Stainless Steel (300 Series)
  - Viton
  - EPDM
  - Concrete
- Depending on the application, other components (psi gauge, flow meter, etc.) may be installed to assist in monitoring system parameters.

**Step 1:** Arrange the ozone system equipment (booster pump, injector and contact vessel) according to mechanical print or as dictated by equipment layout and serviceability considerations. Do not secure booster pump(s) and contact vessel to housekeeping pads at this point. Dry fit plumbing as appropriate to insure proper fit and location before making permanent connections.

**Step 2:** Install a tee or plumbing saddle into the main water line after the filter (if so equipped) and before the flow diversion mechanism. The purpose of the mechanism is to restrict water flow so water is diverted into the side stream (see Figure 2). If such a mechanism is not present in the system (such as a heater bypass valve, etc.), it will require installation of a valve (butterfly, gate or ball) or a flow controller.

**Step 3:** Plumb a line from the tee or plumbing saddle to the booster pump. For serviceability of the equipment in the side stream loop, be sure to install an isolation valve between the tee or saddle and the booster pump.

**Step 4:** Plumb from the booster pump to the injector manifold. Make sure to note the correct direction of flow, indicated by a blue arrow on the inlet side of the manifold body. The check valve assembly is strapped to the manifold using wire ties. Remove the assembly; using Teflon® tape, install it onto the top opening of the injector.

- Step 5:** Using Teflon® tubing, run tubing from the inlet of the check valve assembly that was just installed onto the top opening of the injector, to the ozone outlet of the ozone system located at the top of the interlock box (see Appendix A).
- Step 6:** Plumb from the injector manifold to the inlet side of the contact vessel. To reduce possible backpressure to the injector, minimize the number of elbows between the injector manifold and contact vessel. The contact vessel is a specified size, determined by water flow requirements. ClearWater Tech contact columns and the 30, 40, 80, and 120-gallon contact tanks have inlet *and* outlet fittings on the bottom of the vessel(s) and are designated with arrows showing the direction of flow. **Note: The inlet and outlet arrows on the contact tanks are under the base of the tank.** The inlet on the 264, 463 and 850-gallon tanks is located at the top with the outlet at the bottom.
- Step 7:** Using a tee or plumbing saddle, plumb from the outlet of the contact vessel back into the main water line. For serviceability of the equipment in the side stream loop, be sure to install an isolation valve between the outlet fitting on the contact vessel and before returning to the main water line.
- Step 8:** Secure the booster pump and contact vessel to solid mounting surfaces using appropriate hardware and according to local codes. If installing a ClearWater Tech contact column, use a ClearWater Tech contact column mounting kit and install according to the instructions below. If installing a contact tank, secure to a solid horizontal surface using mounting flange or feet
- Step 9:** Install the contact vessel venting system into the top of the vessel. If using the ClearWater Tech contact column, the vent kit supplied includes fittings, a control valve and Teflon® tubing. The contact tank venting system includes an air relief valve, fittings and a length of Teflon® tubing. Depending on conditions, the vented gas may be directed to an ozone destruct system, to atmosphere or to the low-pressure side of the water system. **Note: Do not direct the tubing to the suction side of any pump in the system.**

### Contact Column Installation (if so equipped)

**Step 1:** Make sure the following hardware items are included in the contact column mounting kit:

- 'L' bracket
- 1/2" concrete anchors
- 6" clamp assembly
- Unistrut bar
- Protective end cap
- Mounting hardware

**Step 2:** Mark the two holes for mounting the 'L' bracket to the wall (see Figure 4). The bracket should be located so that the 6" clamp assembly will be approximately 12" from the top of the contact column. Drill a 1/2" hole at each of the marks, about 3 1/2" deep. Insert a concrete anchor into each hole with the threaded end facing outward. Slip the 'L' bracket over the threaded ends of the anchors, followed by a washer for each anchor. Secure the bracket to the wall by threading a nut onto each anchor and tightening.

**Step 3:** Cut the unistrut bar to the desired length and attach it to the 'L' bracket using hardware provided.

**Step 4:** Slip the two sides of the 6" clamp into the unistrut bar and then around the contact column. Tighten the retaining bolt, securing the contact column to the unistrut bar.

**Step 5:** Slip the protective end cap over the exposed end of the unistrut bar.

### Side stream Plumbing Installation Diagram

Figure 3

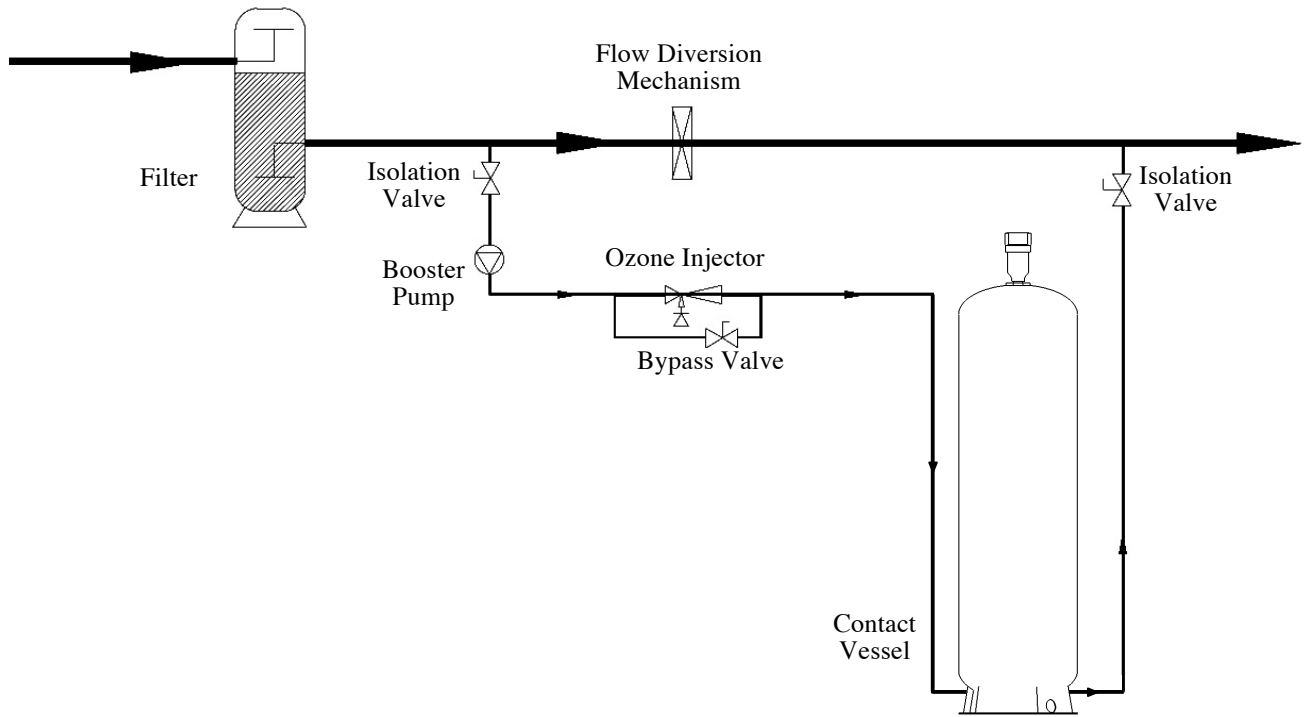

### Full Flow Plumbing Installation Diagram

Figure 4

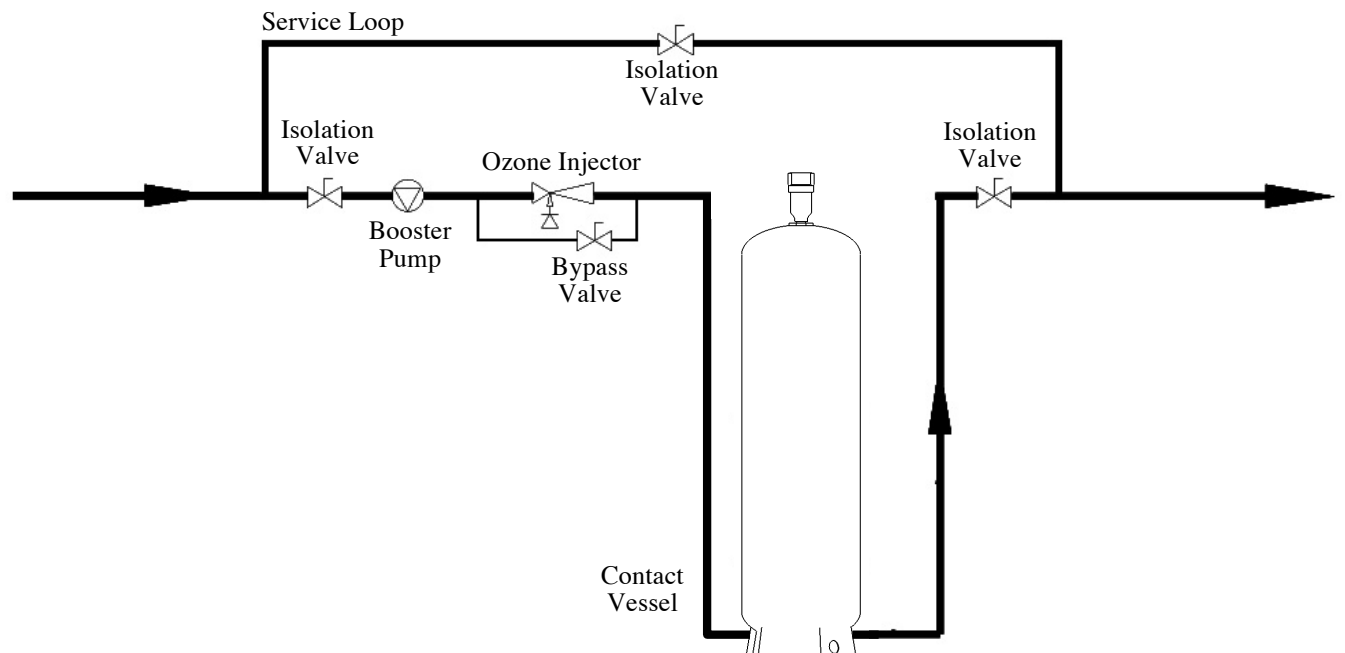

### Contact Column Installation Diagram

Figure 5

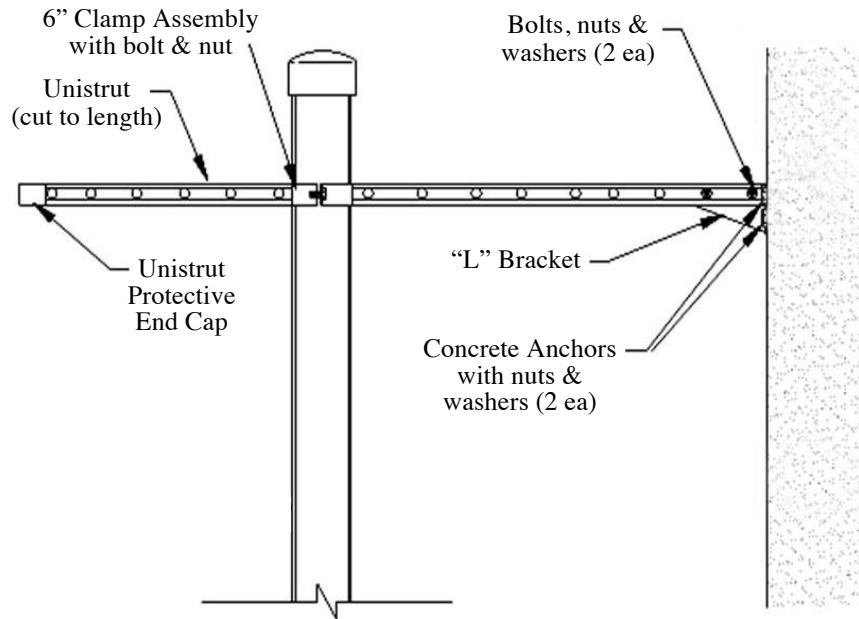

### Contact Column Exploded View

Figure 6

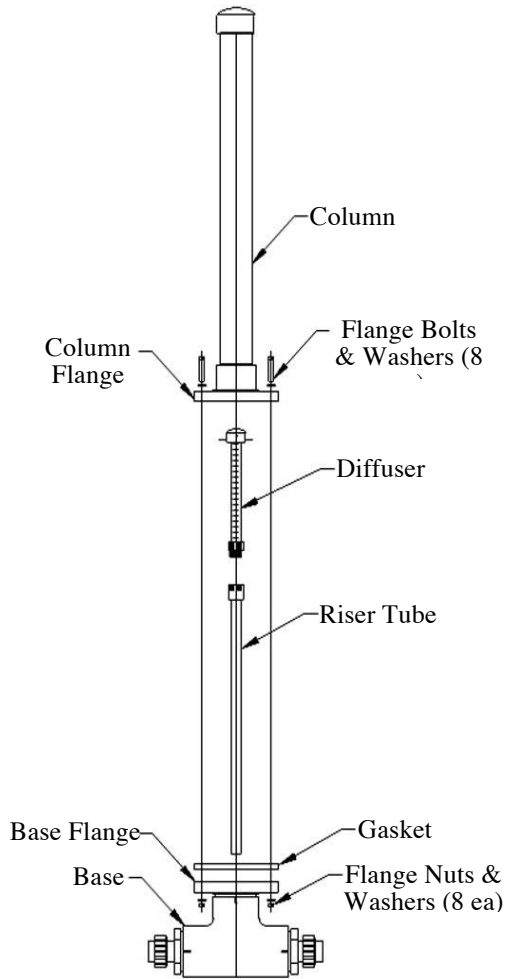

# Installation Procedures – Electrical

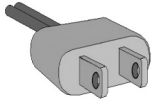

The M-15/O<sub>2</sub>, P-20/O<sub>2</sub>, CD15/O<sub>2</sub>, and CD20/O<sub>2</sub> Series ozone generation systems are designed to be hard wired to the main power source with the specific input voltage requirements. All possible pre-wiring has been completed at the factory. Logic schematics have been provided in the Appendix D.

## Notes:

- All electrical connections should be made by a licensed, qualified electrician. All local, state and national codes must be observed.
- Make sure all power is off at the main circuit breaker before making any electrical connections

**Step 1:** Conforming to all local, state and national electrical codes, ground the ozone system to a true earth ground. Use solid copper bonding wire (usually #8 AWG) from the copper-bonding lug located on the base of the ozone system.

**Step 2:** Terminal Strip Connections – based on the input voltage of your unit, wire up power to the unit and the various control signals based on the information provided below.

Power Consumption (without pump)			
Input Voltage	120VAC 60Hz	220VAC 50Hz	240VAC 60 Hz
M-15/O <sub>2</sub>	5.4 Amps	2.8 Amps	2.8 Amps
P-20/O <sub>2</sub>	8.3 Amps	4.6 Amps	4.2 Amps
CD15/O <sub>2</sub>	5.4 Amps	2.8 Amps	2.8 Amps
CD20/O <sub>2</sub>	8.3 Amps	4.6 Amps	4.2 Amps

The ozone generator, oxygen concentrator and pump (if installed) come prewired from the factory. The information below regarding these items is provided in case the system ever needs to be required. **NOTE: Be sure to ground the unit to the bonding lug before performing any other wiring.**

**Terminal 1 and 2 – Main Power.** Depending on the rated voltage of the ozone system, wire a 30 AMP circuit from the service disconnect box to terminal 1 and 2 on the terminal strip inside the electrical interlock box. Use #12 AWG wire.

- 120VAC Domestic System – Terminal 1 – 120VAC Line, Terminal 2 – Neutral
- 240VAC Domestic System – Terminal 1 – 240VAC L1, Terminal 2 – 240VAC L2
- 220/240VAC International System – Terminal 1 – 220/240VAC Line, Terminal 2 – Neutral

**Terminal 3 – System Neutral.** Depending on the rated voltage of the ozone system, provide a true neutral for this position. **NOTE: The system will not operate without a true neutral.** Use #12 AWG wire.

- 120VAC Domestic System – Terminal 3 – Jump to Terminal 2
- 240VAC Domestic System – Terminal 3 – Neutral
- 220/240VAC International System – Terminal 3 – Jump to Terminal 2

**Terminal 4 – MCI (Motor Control Interlock).** This is an interlock from the main circulation pump to the ozone system, a control voltage only. Run a line from the motor starter to this terminal. Should this feature not be used, simply install a jumper from terminal 1 to terminal 4. **Note: The unit will not function without a voltage signal at this location.** Use #18 AWG.

- 120VAC Domestic System – Terminal 4 – 120VAC
- 240VAC Domestic System – Terminal 4 – 120VAC
- 220/240VAC International System – Terminal 4 – 220/240VAC

# Interlock Box Terminal Strip Connections

Figure 7

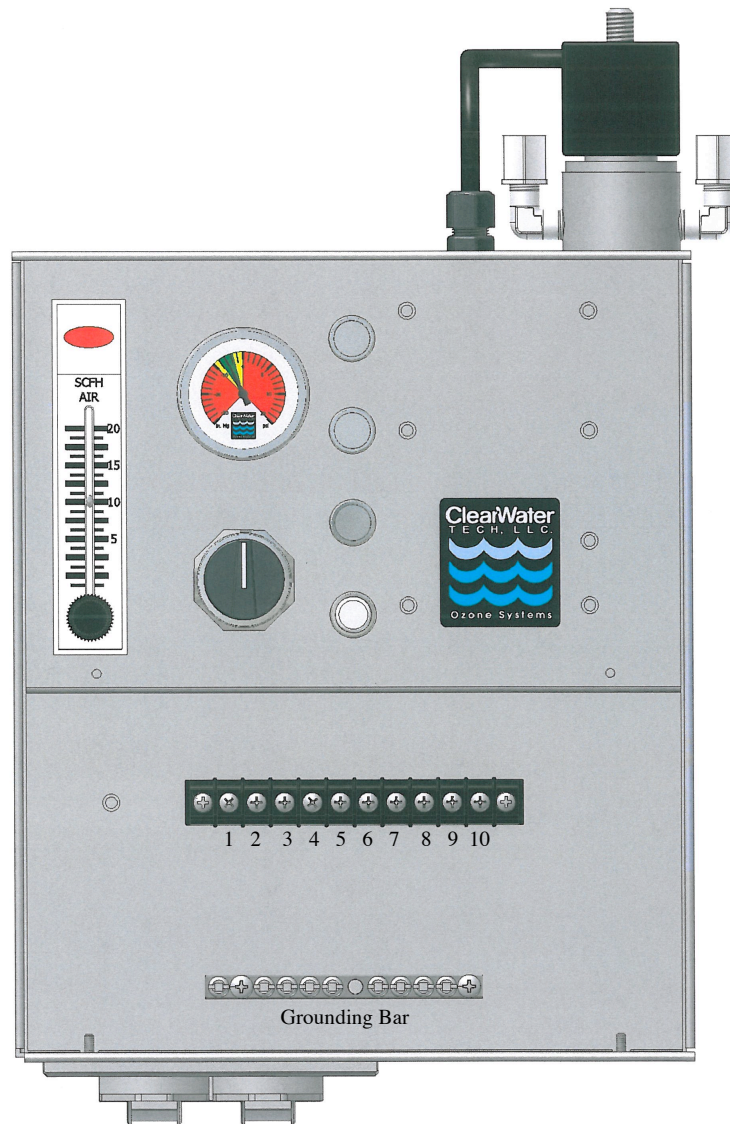

### 120 VAC Domestic Models

1. Line in 120VAC
2. Neutral In
3. Neutral In
4. MCI In 120VAC
5. ORP Line In 120VAC
6. ORP Neutral
7. Booster Pump Out 120VAC
8. Booster Pump Neutral
9. Ozone Generator Out 120VAC  
Oxygen Concentrator Out 120VAC
10. Ozone Generator Neutral  
Oxygen Concentrator Neutral

### 240 VAC Domestic Models

1. Line in 240VAC (L1)
2. Line in 240VAC (L2)
3. Neutral In
4. MCI In 120VAC
5. ORP Line In 120VAC
6. ORP Neutral
7. Booster Pump Out 240VAC (L1)
8. Booster Pump Out 240VAC (L2)
9. Ozone Generator Out  
240VAC (L1)  
Oxygen Concentrator Out  
240VAC (L1)
10. Ozone Generator Out  
240VAC (L2)  
Oxygen Concentrator Out  
240VAC (L2)

### 220/240 VAC International Models

1. Line in 220/240VAC
2. Neutral In
3. Neutral In
4. MCI In 220/240VAC
5. ORP Line In 220/240VAC
6. ORP Neutral
7. Booster Pump Out 220/240VAC
8. Booster Pump Neutral
9. Ozone Generator Out 220/240VAC  
Oxygen Concentrator Out  
220/240VAC
10. Ozone Generator Neutral  
Oxygen Concentrator Out  
220/240VAC

**Terminal 5 and 6 – ORP (Oxidation Reduction Potential) Controller, Line.** This is a control voltage only from the controller to a relay integrated into the interlock box. When the switch on the front of the interlock box is in the “Auto” position, the ozone generator will be controlled by the ORP signal. **Note: To Override the ORP control signal, simply turn the ozone switch on the electrical interlock box to the “ON” position.** Use #18 AWG.

120VAC Domestic System – Terminal 5 – 120VAC, Terminal 6 – Neutral

240VAC Domestic System – Terminal 5 – 120VAC, Terminal 6 – Neutral

220/240VAC International System – Terminal 5 – 220/240VAC, Terminal 6 – Neutral

**Terminal 7 and 8 – Booster Pump Out.** Factory wired, #12 AWG inside 1/2” watertight flex conduit (if installed) The booster pump will stay on in either the “On” or “Auto” position on the switch on the electrical interlock box as long as an MCI signal is provided.

120VAC Domestic System – Terminal 7 – 120VAC Line, Terminal 8 – Neutral

240VAC Domestic System – Terminal 7 – 240VAC L1, Terminal 8 – 240VAC L2

220/240VAC International System – Terminal 7 – 220/240VAC Line, Terminal 8 – Neutral

**Terminal 9 and 10 – Ozone Generator and Oxygen Concentrator Out.** Factory wired, #18 AWG to the ozone generator and #18 AWG to the oxygen concentrator. When the switch on the electrical interlock box is in the “ON” position, the ozone generator and oxygen concentrator will be energized when a MCI signal is provided and will remain on if a vacuum is present on the ozone output within 15 seconds after the system begins.

When the switch on the electrical interlock box is in the “AUTO” position, the ozone generator and oxygen concentrator will be energized when a MCI signal is provided and an ORP signal is provided. The system will continue to produce ozone as long as a vacuum is present on the ozone output within 15 seconds after the system begins.

**NOTE: The system will only operate for 15 seconds without vacuum. To reset the time sequence, turn the switch on the electrical interlock box to the “OFF” position and then back to “ON” or “AUTO”**

120VAC Domestic System – Terminal 9 – 120VAC Line, Terminal 10 – Neutral

240VAC Domestic System – Terminal 9 – 240VAC L1, Terminal 10 – 240VAC L2

220/240VAC International System – Terminal 9 – 220/240VAC Line, Terminal 10 – Neutral

# Installation Procedures – Pneumatic

This section outlines the steps required to complete the ozone system pneumatic hook-ups. The system components include the air preparation system, ozone generator, vacuum break, and ozone injector manifold (see Figure 7). The air preparation system provides the ozone generator with a source of oil-free oxygen-enriched air (90% +/- 3% oxygen purity at -100°F dew point) or dry air (20% oxygen purity). The air is drawn from the ozone generator (where ozone is produced from the oxygen in the air stream) and through the vacuum break by the suction created at the ozone injector manifold.

## Hook-Ups: Ozone Generator To Vacuum Break & Vacuum Break to Injector Manifold

Figure 8

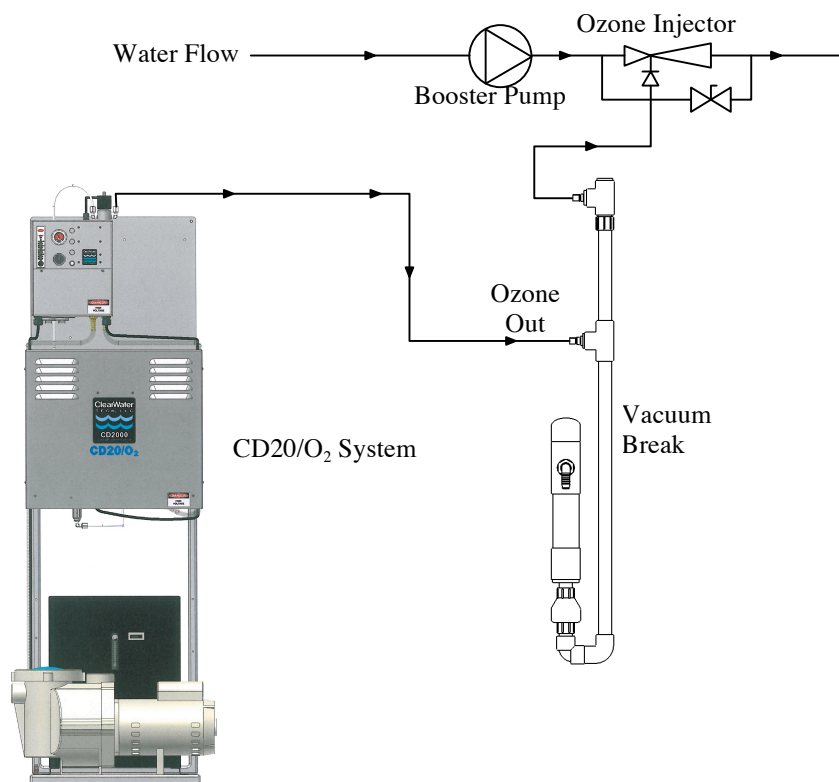

Shown: ClearWater Tech CD20/O<sub>2</sub> with booster pump

## Hook-Ups: Ozone generator-to-vacuum break & vacuum break-to-injector manifold

The ClearWater Tech vacuum break provides a positive atmospheric “break” between the ozone injector manifold and the ozone generator, preventing water from flowing back into the ozone generator should the venturi check valve fail. Under normal operating conditions, the vacuum break’s flapper valve (see Figure 9) is closed, allowing the vacuum created by the venturi to draw the output gas from the ozone generator. If the check valve at the venturi begins to leak or fails completely, vacuum is interrupted and water will flow toward the ozone generator. With the vacuum break properly installed between the venturi and the ozone generator, the water will flow down the riser tube (away from the ozone generator) and out to drain, protecting the ozone generator from potential water damage.

**Step 1:** Select a suitable vertical surface that is accessible and in close proximity to both the ozone generator and the ozone injector manifold.



- Step 2:** Install the two Clic® mounting clamps provided onto the vertical surface so that the vacuum break is in a vertical position and the drain holes are *below* the level of the ozone generator ozone outlet fitting. One clamp should be located so it fits around the Riser Tube Elbow, and the other so it fits around the bottom of the Lower Tee, (see Figure 9).
- Step 3:** Remove the Fill Port Cap located on top of the Riser Tube and fill the Riser Tube with clean water (no particulate matter) to "Fill Level" line (see Figure 9).
- Step 4:** Re-install the Fill Port Cap, using pliers or a wrench to tighten. **Note: Do not over-tighten as damage to PVC fittings may occur.**
- Step 5:** Install the check valve with compression fitting (located in the parts kit or attached to the ozone generator with a wire tie) into the stainless steel ozone outlet located at the bottom of the ozone generator.
- Step 6:** Connect one end of a suitable length of Teflon® ozone delivery line to the fittings installed into the ozone outlets (see Step 5 above). Attach the other end of the Teflon® delivery line to the fitting threaded into the Upper Tee. As an additional backflow prevention measure, loop this length of tubing as high as is practical between the two connection points.
- Step 7:** Connect one end of a second length of Teflon® delivery line to the fitting threaded into the Lower Tee. Attach the other end of the delivery line to the fitting located on top of the check valve assembly, which was installed at the injector manifold.
- Step 8:** Adjustments to the valve on the ozone injector manifold will be necessary. These steps are covered in Chapter 7, "Start-up and Calibration Procedures."

## Vacuum Break Detail

Figure 9

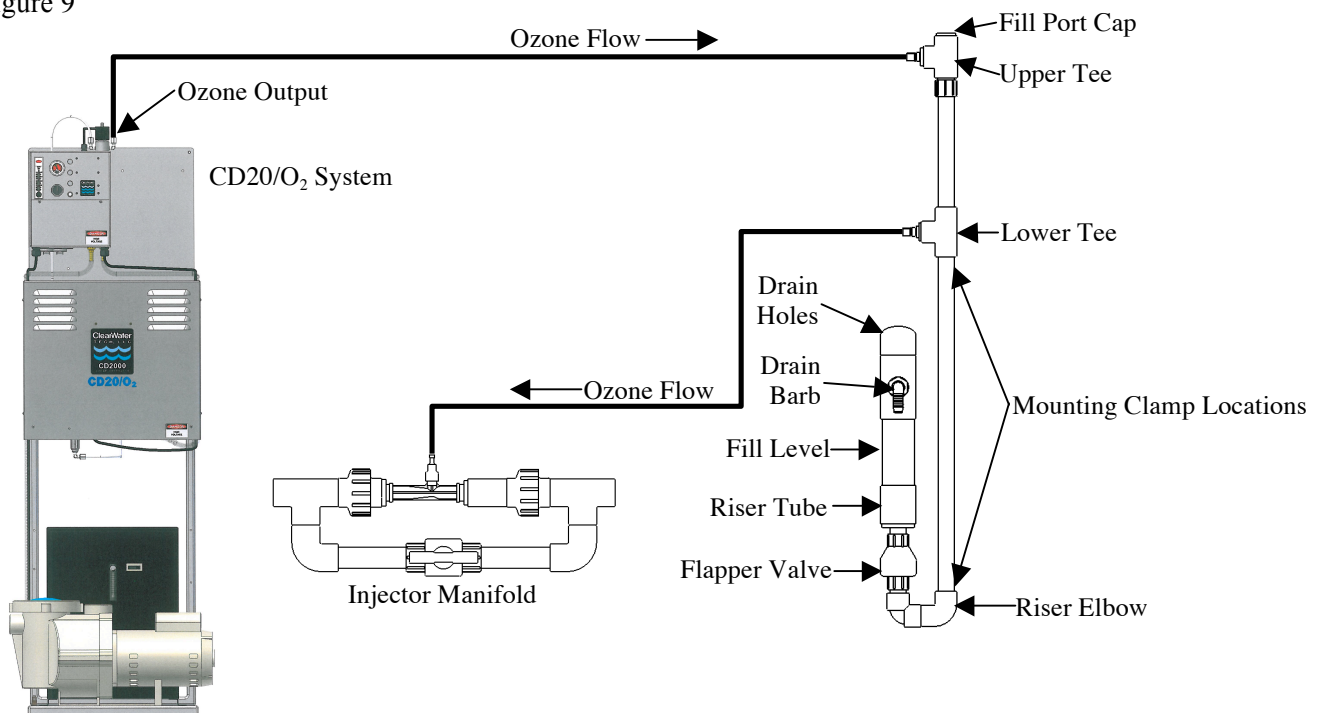

## Hook-Up: Contact vessel-to-ozone destruct system (if so equipped)

The ClearWater Tech ozone off-gas destruct system consists of two components: the ozone destruct unit (a heated chamber filled with manganese dioxide and copper oxide) and a water trap. Used in conjunction with the ClearWater Tech off-gas vent, this two-stage ozone destruct system is an efficient way to properly vent the ozone system contact vessel (see Figure 10).

### NOTES:

- **The ozone destruct unit must have constant power to function properly. Make sure it is plugged into an unswitched 120VAC outlet or wired to unswitched 240VAC power. Once up to temperature, the unit will remain warm to the touch.**
- **It is normal for small amounts of water to drain from the water trap, so it must be plumbed to waste appropriately**

**Step 1:** Select a suitable vertical surface adjacent to the ozone system contact vessel. Using the Clic® mounting clamps provided, mount the water trap to the surface.

**Step 2:** Using the mounting tabs, mount the ozone destruct unit adjacent to the water trap.

**Step 3:** Using Teflon® tape, install the small ball valve into the opening (at the tee or inlet) of the water trap. Using Teflon® tape, install the thread-by-compression fitting provided into the small ball valve.

**Step 4:** Using the compression fitting, attach one end of a suitable length of the Teflon® tubing to the compression fitting on top of the contact vessel (the fitting is threaded directly into the cap of the contact *column* and is threaded into the off-gas vent on the top of a contact *tank*). Attach the other end of the tubing to the inlet of the small ball valve (see Step 3 above) in the water trap.

**Step 5:** Using the compression fitting provided, attach another suitable length of Teflon® tubing to the fitting on top of the water trap. Attach the other end of the tubing to the inlet compression fitting on the bottom of the ozone destruct unit.

**Step 6:** Attach a suitable length of braided tubing to the fitting on the bottom of the water trap. Terminate the other end to appropriate waste or drain.

**Step 7:** Plug the ozone destruct unit into an unswitched 120VAC outlet or wire to unswitched 240VAC power and allow it to warm up. **Warning: The destruct unit will be warm to the touch when in operation.**

# Ozone Destruct System Detail

Figure 10

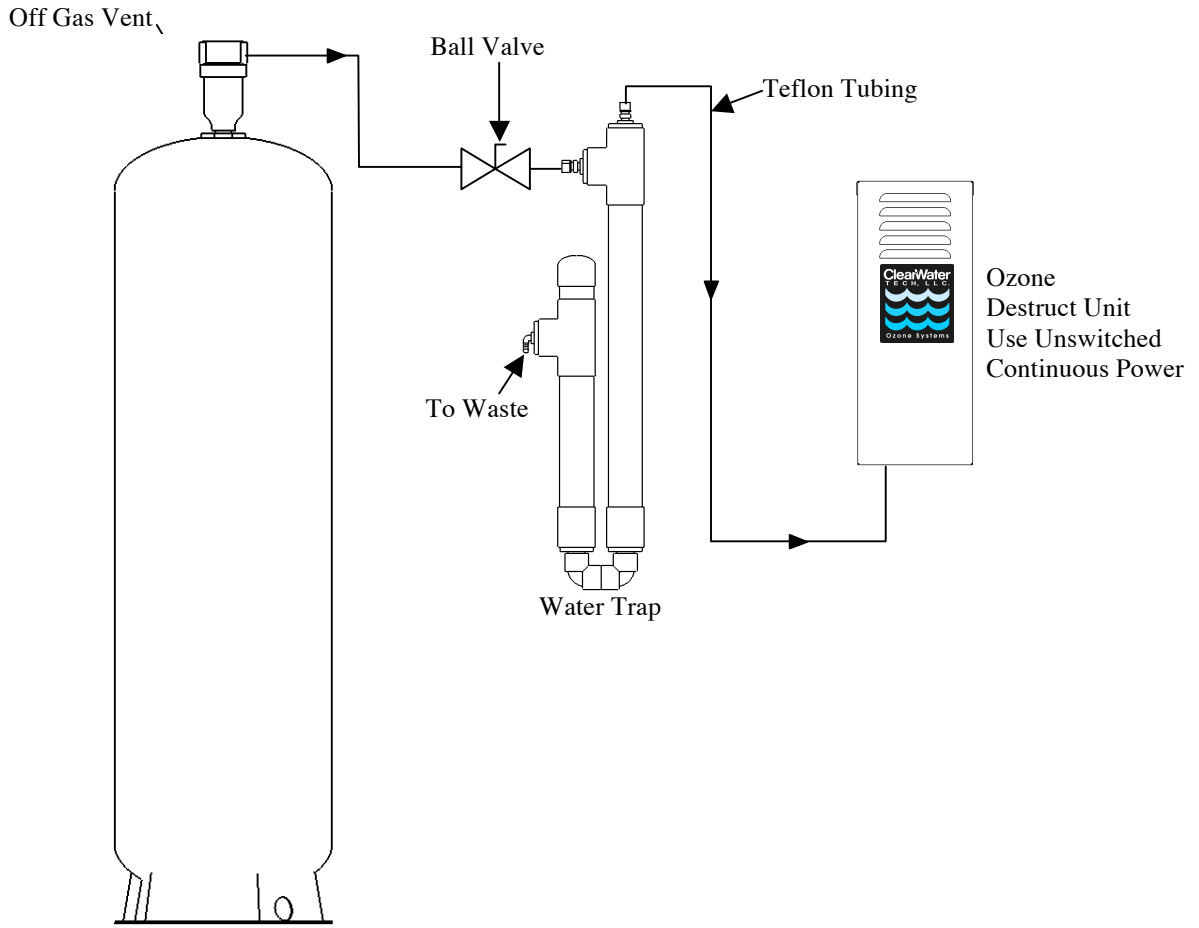

# Startup and Calibration

The previous sections of this manual have involved comparatively static procedures: making electrical and pneumatic connections, fitting pipe, etc. This section involves the dynamic process of starting up and balancing the components of the ozone system, including initiating water flow, making air and water flow adjustments, etc.



Maximum performance and reliability is achieved when the prescribed air flow is maintained at the ozone generator while the system is operating under a slight vacuum (measured in inches of mercury, or “in.Hg”). Air from the air preparation system is flowing toward the ozone generator under pressure, and from the ozone generator under vacuum (created by the ozone injector manifold). The change from pressure to vacuum occurs at the SCFH/vacuum gauge assembly mounted in the electrical interlock box. If the vacuum level is too high but air flow levels are correct, opening the ball valve on the injector manifold(s) slightly will decrease the vacuum by increasing the amount of water flowing through the bypass of the ozone injector manifold. Similarly, if the vacuum level is too low, closing the ball valve on the injector manifold(s) slightly will increase the vacuum.

## Air Preparation System, Ozone Generator & Ozone Injector

**Step 1:** Make sure all isolation valves in the ozone water system are open (Figures 2 or 3 show recommended isolation valve locations).

**Step 2:** Start up hydraulics. Allow the water system to reach hydraulic equilibrium (contact vessel(s) full, off-gas vent(s) operating, etc.) and observe for plumbing leaks. **Note: Water flow must be established through the main water pump and the ozone system booster pump (if so equipped).**

**Step 3:** Close the ball valve on the injector manifold about half way.

**Step 4:** Make sure electrical power to all ozone system electrical components is on. Make sure all of the appropriate electrical signal wire have been connected (see Installation Procedures – Electrical). The main power switch of the air preparation system must be in the “ON” position, if so equipped (see Figure 8). Turn the switch on the electrical interlock box to the “ON” position.

**Step 5:** The needle valve on the oxygen concentrator (see Figure 8) will be set at the factory to be as open as possible to limit the amount of restriction this valve places on the flow of oxygen. Verify that this needle valve is still opened up.

**Step 6:** Once system begins observe the vacuum gauge in the electrical interlock box. If the needle is in the red zone on the pressure (PSI) side of the gauge, gradually close the ball valve on the injector manifold until the needle moves into the green zone. If the needle is in the red zone on the vacuum (in.Hg) side of the gauge, gradually open the ball valve on the injector manifold until the needle moves into the green zone. **NOTE: The system will only operate for 15 seconds if vacuum is too low. To reset the time sequence, turn the switch on the electrical interlock box to the “OFF” position and then back to “ON”.**

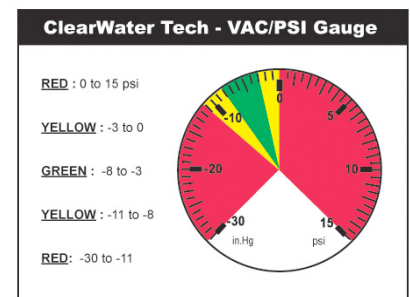

**Step 7:** Using the needle valve in the electrical interlock box’s flow meter, adjust the air flow through the system to the value listed in the Pneumatic Operating Parameters found in Figure 9. **NOTE: The flow through the gauge will be under vacuum, so the value read on the meter under normal operation will be higher than the flow listed in the specifications because the value listed in the specifications is not under vacuum (0 in Hg).** Adjusting the flow through the flow meter will effect the vacuum. **Note: the**

**system may shut down if the vacuum drops too low. To reset the time sequence, turn the switch on the electrical interlock box to the “OFF” position and then back to “ON”.**

- Step 8:** Repeat steps 6 and steps 7 until the flow and vacuum match the values listed in the Pneumatic Operating Parameters found in Figure 9.
- Step 9:** Perform a final check of all air connections from the air preparation system to the ozone injector manifold. Repair leaks as required. Check all system water connections, including the ozone injector manifold, vacuum break and contact vessel. Repair leaks as required. **Note: The check valve at the ozone generator and ozone injector manifold may make a humming noise. This is normal.**
- Step 10:** Make sure the Ozone Generator power switch is set to “ON”. CD15/O<sub>2</sub> and CD20/O<sub>2</sub> only - Observe all indicating LEDs on the front cover of the ozone generator for proper operation and adjust the manual ozone output knob to desired level setting.

**Pneumatic Operating Parameters**

Figure 11

<b>M-15/O<sub>2</sub></b>	<b>Operating Range</b>	<b>Optimum</b>
Air Preparation System Air Flow	6 to 8 SCFH	7 SCFH
Air Flow Gauge Reading	6.6 to 8.8 CFH	7.7 CFH
Vacuum gauge	-3 to -8 in Hg	-5 in Hg

<b>CD15/O<sub>2</sub></b>	<b>Operating Range</b>	<b>Optimum</b>
Air Preparation System Air Flow	0 to 8 SCFH	7 SCFH
Air Flow Gauge Reading	0 to 8.8 CFH	7.7 CFH
Vacuum gauge	-3 to -8 in Hg	-5 in Hg

<b>P-20/O<sub>2</sub></b>	<b>Operating Range</b>	<b>Optimum</b>
Air Preparation System Air Flow	12 to 16 SCFH	14 SCFH
Air Flow Gauge Reading	13.1 to 17.5 CFH	15.3 CFH
Vacuum gauge	-3 to -8 in Hg	-5 in Hg

<b>CD20/O<sub>2</sub></b>	<b>Operating Range</b>	<b>Optimum</b>
Air Preparation System Air Flow	0 to 16 SCFH	14 SCFH
Air Flow Gauge Reading	0 to 17.5 CFH	15.3 CFH
Vacuum gauge	-3 to -8 in Hg	-5 in Hg

### M-15/O<sub>2</sub> and P-20/O<sub>2</sub> – Ozone Generator Drive Board LED Function

Figure 12

LED	Function
MAIN POWER	When illuminated, this “Red” LED indicates that main power is supplied to the drive board.

### M-15/O<sub>2</sub> and P-20/O<sub>2</sub> – Drive Module

Figure 13

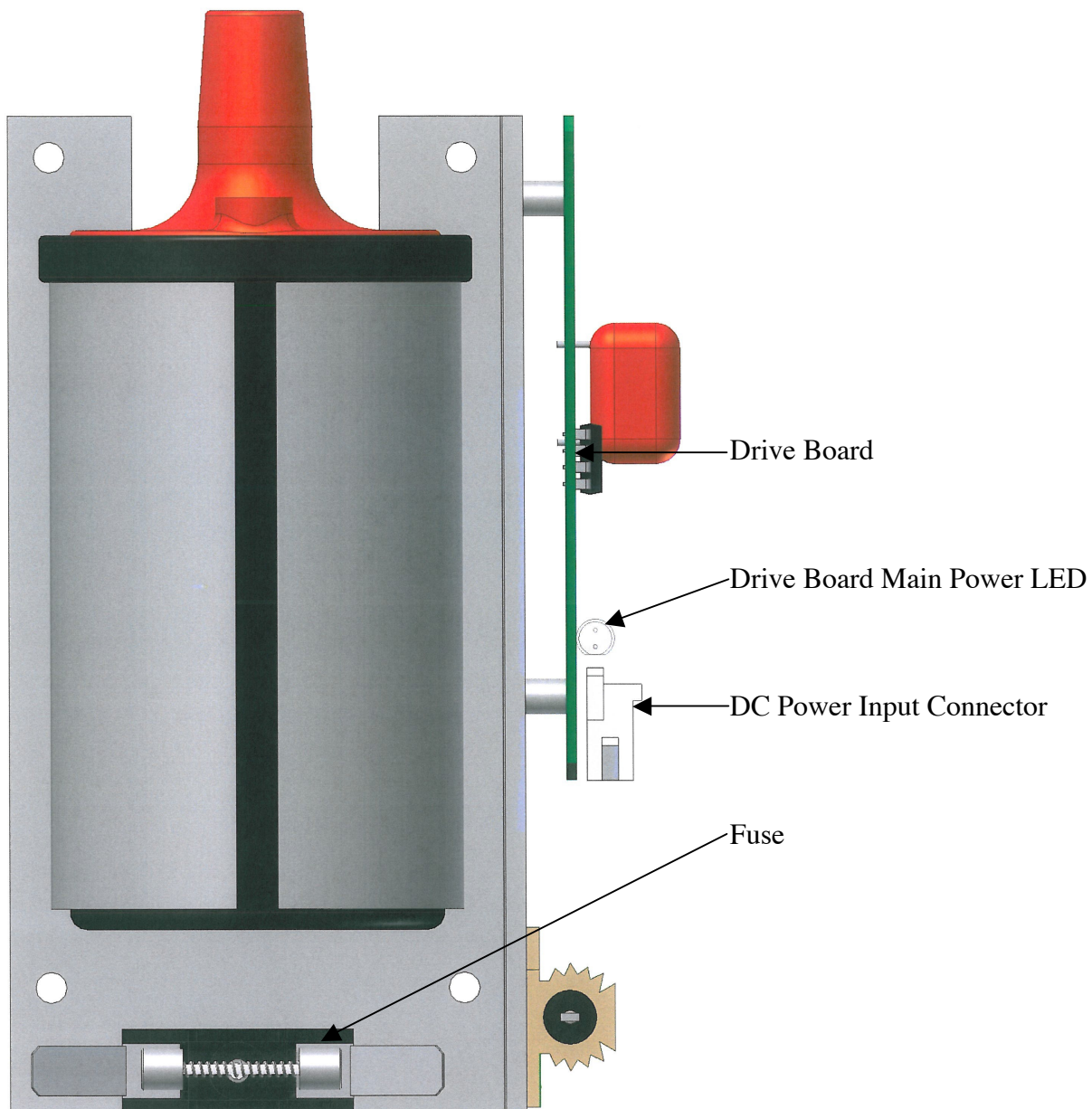

### CD15/O<sub>2</sub> and CD20/O<sub>2</sub> – Ozone Generator Drive Board LED Function

Figure 14

LED	Function
12V MAIN POWER	When illuminated, this “Green” LED indicates that main power is supplied to the low voltage control circuitry.
XFMR POWER	When illuminated, this “Green” LED indicates that 48V Buss power is supplied to the drive module transformer (XFMR).
OZONE OUTPUT	The “Amber” ozone output LED will illuminate when ozone is being generated. The LED will also pulse as the output increases or decreases with either the Manual Ozone Output Control located on the bottom of the ozone generator (see Appendix A), or from a Remote 4-20mA signal (see “Installation Procedures – Electrical”).
FAULT	When illuminated, this “Red” LED indicates that there is a fault with the drive module or the Ozone Reaction Chamber. If this LED is illuminated, refer to the Troubleshooting Guide. <b>Notes: If the drive module goes to a fault condition, the drive board will restart every 30 seconds. If the fault is not remedied the drive module will continue to go into a fault mode. When the drive module is in fault mode ozone will not be generated.</b>

### CD15/O<sub>2</sub> and CD20/O<sub>2</sub> – Drive Board

Figure 15

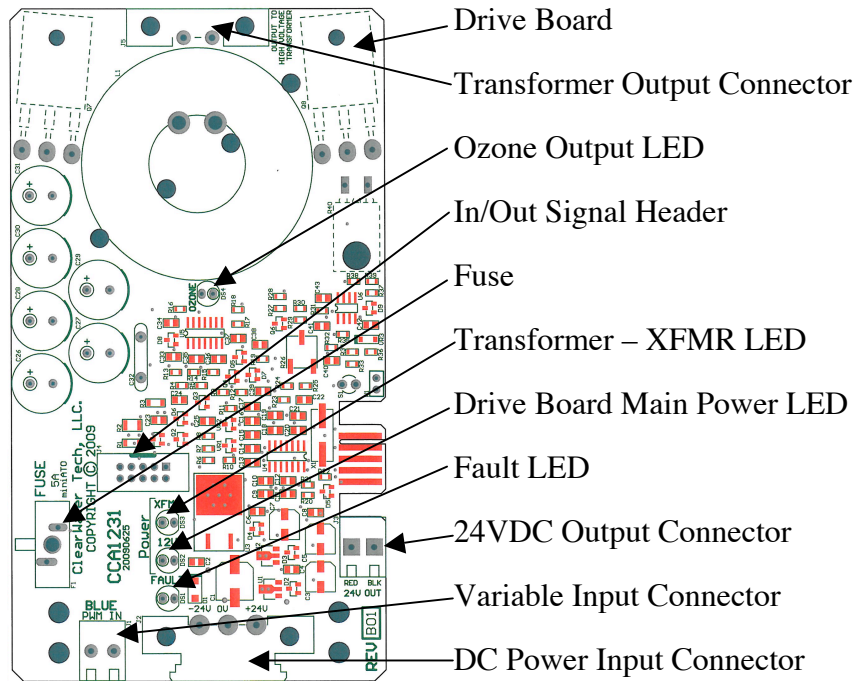



### **Vacuum Break (Optional)**

Check the water level in the vacuum break, making sure it is *above* the flapper valve (see Figure 9). If water is not pressing downward on the flapper valve it will open, causing a loss of vacuum. The water level in the vacuum break should remain static with no air bubble movement. A loss of vacuum means ozone cannot be drawn through the vacuum break, which in turn can cause an ozone leak (see Troubleshooting Guide).

### **Ozone Destruct System**

Adjust the small ball valve at the tee of the water trap (see Figure 10) so that only a small amount of water is “spitting” into the trap. This will indicate that the contact vessel is full and only a very small amount of water is allowed to escape. Do not close this valve completely. Doing so may cause back pressure on the contact vessel and injection manifold, which will cause a loss of vacuum (see Troubleshooting Guide).

# Maintenance

---



Maintenance of the M-15/O<sub>2</sub>, P-20/O<sub>2</sub>, CD15/O<sub>2</sub>, and CD20/O<sub>2</sub> ozone system is critical to its longevity and operating efficiency. While all system components are built to provide years of reliable service with minimum maintenance, following the procedures outlined below is strongly recommended.

All maintenance procedures have been segmented by interval: daily, monthly, semi-annual and annual. Daily procedures involve quick, visual checks for changes in normal operating conditions. Monthly, semi-annual and annual procedures include cleaning and/or replacement of certain critical parts.

## **NOTES:**

- **The ozone generator warranty states that it “does not extend to any product or part which has been damaged or rendered defective as a result of use of parts not sold by ClearWater Tech, or service or unit modification not authorized by ClearWater Tech” Please contact your ClearWater Tech dealer if you have any questions about any maintenance procedure *before* you begin that procedure.**
- **CAUTION: Observe all common safety practices and review the “Safety Warnings and Instructions” section before attempting any maintenance procedure that requires the use of tools and/or shutting down the ozone system.**

## **Daily Procedures**

### Control Panel

- **Gauges and Meters:** Observe normal operating parameters of all gauges and meters. Make sure they are within the ranges shown on the “Pneumatic Operating Parameters” chart Figure 9. Adjust if necessary by following the steps outlined in the “Startup & Calibration” section.

### Ozone Generator

- **CD15/O<sub>2</sub> and CD20/O<sub>2</sub> only -** Observe all indicating LEDs on the front cover of the ozone generator for proper operation and adjust the manual ozone output knob to desired level setting.

### Vacuum Break (Optional)

- **Water Level:** Check the water level in the vacuum break. Make sure it is above the flapper valve in the overflow tube. Fill as required by removing the threaded fitting on top of the riser tube until water is up to the ‘Fill Level’ in the overflow tube (see Figure 11).

### Injection Manifold (Optional)

- **Check Valve:** Inspect the Teflon® ozone delivery line that runs between the vacuum break and the check valve assembly on the suction port of the ozone injector manifold. If water is observed in the delivery line near the check valve assembly, the check valve has failed. See Troubleshooting Guide.

## Monthly Procedures

### Air Preparation System

- **Cooling Fan Operation:** Check to make sure the cooling fan mounted on the side panel of the air preparation system is operating (if so equipped). If not, refer to the Troubleshooting Guide.
- **Cover Filter:** Check the cover filter element mounted on the side of the air preparation system and clean as required. Operating conditions in the equipment area will dictate the frequency required for this procedure. Remove the filter element and clean with soap and water, drying them completely before re-installing.

### Ozone Generator

- **M-15/O2 and P-20/O2 only: Drive Module Operation:** The Drive Module is made up of two components: the drive board and the drive transformer. With the ozone generator cover removed and the cover switch engaged, check for illumination of the drive module "Power" LED(s) (for LED locations, see Figure 16); if not illuminated see Troubleshooting Guide. This procedure is to observe the complete operating function of the drive module(s). **CAUTION: The ozone generator will remain energized with the cover removed and the cover switch engaged. Do not touch anything inside the ozone generator while the system is energized and the cover removed! Please consult your ClearWater Tech dealer before attempting this procedure.**
  - **Main Power LED:** When illuminated, this "Red" LED indicates that main power is supplied to the drive module.
- **CD15/O2 and CD20/O2 only: Drive Module Operation:** The Drive Module is made up of two components: the drive board and the drive transformer. With the ozone generator cover removed and the cover switch engaged, check for illumination of the drive module "Ozone Output" LED(s) (for LED locations, see Figure 16); if not illuminated see Troubleshooting Guide. This procedure is to observe the complete operating function of the drive module(s). **CAUTION: The ozone generator will remain energized with the cover removed and the cover switch engaged. Do not touch anything inside the ozone generator while the system is energized and the cover removed! Please consult your ClearWater Tech dealer before attempting this procedure.**
  - **Main Power LED:** When illuminated, this "Green" LED indicates that main power is supplied to the drive module up to the "on board" fuse of the drive board.
  - **Transformer Power LED:** When illuminated, this "Green" LED indicates that 48V Buss power is available to the drive module transformer (XFMR) from the "on board" fuse of the to the drive transformer.
  - **Ozone Output LED:** The "Amber" ozone output LED will illuminate when ozone drive is being generated. The LED will also pulse as the output increases or decreases with either the Manual Ozone Output Control located on the bottom of the ozone generator (see Appendix A), or from a Remote 4-20mA signal (see "Installation Procedures – Electrical").
  - **Fault LED:** When illuminated, this "Red" LED indicates that there is a fault with the drive module or the Ozone Reaction Chamber. If this LED is illuminated, refer to the Troubleshooting Guide. **Notes: If the drive module goes to a fault condition, the drive board will restart every 15 seconds. If the fault is not remedied the drive module will continue to go into a fault mode. When the drive module is in fault mode ozone will not be generated. Before proceeding further replace the ozone generator cover.**
- **Cooling Fan Operation:** Check to make sure the two cooling fans (mounted on the bottom panel of the ozone generator cabinet) are operating. If not, refer to the Troubleshooting Guide.
- **Cooling Fan Filters:** Check the cooling fan filter elements mounted on the bottom of the ozone generator (see Appendix A) and clean as required. Operating conditions in the equipment area will dictate the frequency required for this procedure. Remove the filter element and clean with soap and water, drying them completely before re-installing (see Figure 17).

### Booster Pump(s)

- **Strainer Baskets:** Check and clean the strainer basket in the booster pump(s) as required (if so equipped)

## Ozone Generator Cooling Fan Assembly

Figure 16

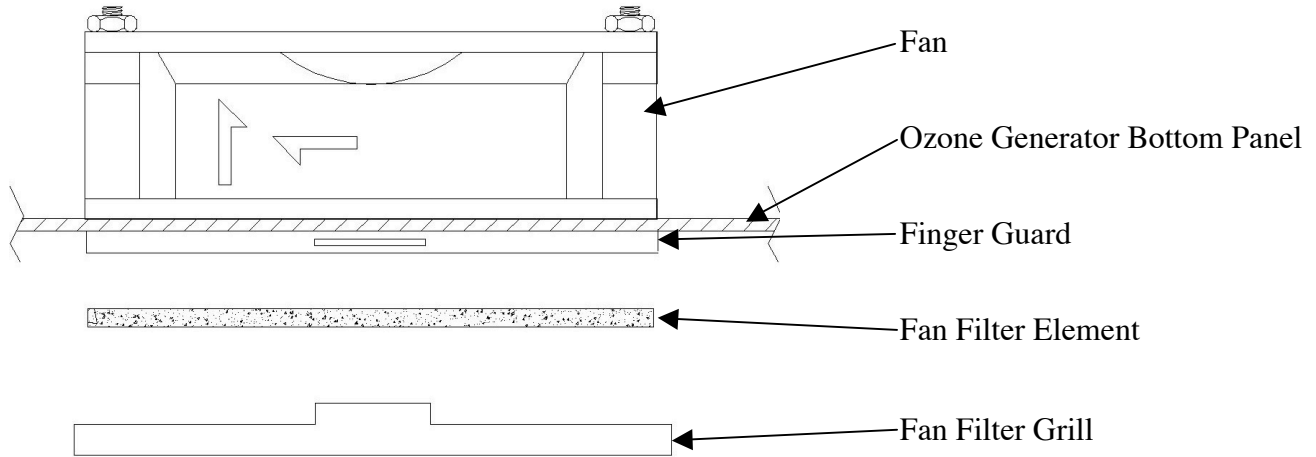

## System Shutdown Procedures

**CAUTION:** The ozone generator operates at high voltage. Follow these steps carefully before performing any semi-annual or annual maintenance procedures.

**Step 1:** Turn off power to any peripheral system hydraulic components.

**Step 2:** Turn the Main Power switch on the electrical interlock box. The Indicator lights on the interlock box should not be illuminated.

**Step 3:** Disconnect the power to the ozone system either at the service disconnect box (if so equipped) or main circuit breaker.

## Semi-Annual Procedures

**CAUTION:** Follow system shutdown procedures (outlined above) before performing any of the following steps.

### Air Preparation System

- **Air Inlet Filter:** Replace the air compressor inlet filter on the air preparation system module (see Figure 10). **Note: Manufacturers' recommended replacement interval is 4,000 hours of operation. Operating conditions in the equipment area will dictate the required frequency of this procedure.**

## Annual Procedures

**CAUTION:** Follow system shutdown procedures before performing any of the following steps.

### Air Preparation System

- **Compressors:** Following the procedures outlined in the compressor rebuild kit, rebuild the two compressor heads on each air preparation system module (see Figure 10). **Note: Manufacturers' recommended interval is 5,000 to 12,000 hours of operation. Compressor performance and/or operating conditions in the equipment area will dictate the required frequency of this procedure.**

### Ozone Generators

- **Cooling Fan Filters:** Clean or replace the cooling fan filter elements as required.

- Inline Filter: Replace the inline particulate filter.
- Reaction Chambers: Remove and disassemble the reaction chamber(s) according to the steps outlined below (see Figure 18). Check the chamber interior and dielectric tube for oil, dirt or moisture.

#### Reaction Chamber Removal and Disassembly

**Note: Read through all the steps before disassembling the reaction chamber.**

- Step 1:** Make sure all power to the ozone generator has been disconnected according to the “System Shutdown Procedures” outlined above.
- Step 2:** Disconnect the white high voltage lead from the black transformer, the black insulation boot will have to be drawn back to expose the connection.
- Step 3:** Disconnect the tubing connections on both ends of the reaction chamber.
- Step 4:** Remove the 4 nuts securing each chamber and remove the reaction chamber from ozone generator.
- Step 5:** Remove retaining screws and washers from the end caps (4 each).
- Step 6:** Using a gentle back-and-forth twisting motion, remove the non-high voltage end cap (the one without the high voltage attachment screw) from the heat sink/cathode assembly. A flat-head screwdriver may be used to gently pry the end cap off, as long as equal pressure is applied to each side of the end cap.
- Step 7:** Remove the high voltage end cap and dielectric from the heat sink/cathode assembly.
- Step 8:** Draw back the white cap along the white high voltage lead at the end cap, this will expose a screw to be removed. Pull/twist the end cap off the glass. Push the contact brush out of the dielectric glass. Also remove the anode (foil-like material) from within the glass, it may come out with the brush.
- Step 9:** Inspect the dielectric, foil, end caps and cathode for breakage, corrosion or debris; then follow the assembly and re-installation steps below.

#### Reaction Chamber Assembly and Re-installation:

- Step 1:** Remove o-rings from end caps, then clean the dielectric glass, end caps and interior of the stainless steel cathode cylinder. Use denatured alcohol and shop towels to clean the above components and be sure to remove all old o-ring debris. A 2” ball hone can be used to clean the major debris out of the cathode if there is heavy buildup. **Note: If the brush’s core is intact, but discolored, it is likely fine. The anode foil may also have been discolored from residual oil and heat, it will not require replacement. If there are ragged ends on the foil, trim them off (1/8”-1/4”) with a pair of scissors.**
- Step 2:** Prepare the end caps for re-assembly by replacing the o-rings. Attach the high voltage lead to the screw and install it onto the high voltage end cap. Thread the hex brush adapter nut, with contact brush attached, onto the interior of the high voltage end cap. Re-tape the threads of the elbow fittings if needed.
- Step 3:** Using a gentle twisting motion, press the non-high voltage end cap onto the heat sink/cathode assembly until flush with the heat sink cooling fins. Turn the end cap to the correct orientation.
- Step 4:** Slide the four end cap retaining screws with washers through the holes in the non-high voltage end cap, aligning them with the heat sink screw bosses. Thread screws into screw bosses until heads are snug against the end cap.
- Step 5:** Next we focus on assembling the rest of the subcomponents before installing them into the reaction chamber. Roll and insert the anode foil into the glass dielectric, center the anode foil in the glass. Secure the foil with a finger against the inside of the glass to keep it centered and insert the contact brush into the dielectric. Insure the foil is centered before fully seating the glass into the high voltage end cap. Clean the glass with denatured alcohol once more, and do not retouch the glass without re-cleaning.
- Step 6:** Hold the reaction chamber upright on a flat surface, empty side up. Grasp the high voltage end cap and lower the glass into the reaction chamber. Press directly downwards on the high voltage end cap to fully

seat the dielectric assembly; the end caps should be flush with the heat sink cooling fins. Turn the end cap to the correct orientation.

**Step 7:** Slide the four end cap retaining screws with washers through the holes in the end cap, aligning them with the heat sink screw bosses. Thread screws into screw bosses until heads are snug against the end cap.

**Step 8:** Re-install the complete reaction chamber assembly into the ozone generator by securing the reaction chamber to its mounts, securing delivery line and connecting the high voltage insulated wire.

#### Vacuum Break

- **Cleaning:** Disconnect ozone delivery lines. Remove the vacuum break from mounting clamps. Disconnect the overflow tube from flapper valve, open flapper and clean the seat with a soft cloth. Remove riser tube threaded fitting and flush riser tube with water. Re-assemble and re-install vacuum break, making sure to add water to correct level (see Figure 11).

#### Injector Manifold

- **Check Valve:** Replace the check valve located at the ozone injection manifold. **Note: Because the system is in the shutdown mode, no vacuum is present at the injector. Therefore, it is normal for some water to be flowing from the injector during this procedure.**

#### Contact Vessel

- **Cleaning:** Contact Column only. Inspect the diffuser slots at the top of the contact column riser tube. If they are clear, no further maintenance is required. If the slots are fouled, disassemble the column and clean as required, following the steps outlined below (see Figure 5).

**Step 1:** Make sure the isolation valves before and after the contact column are closed.

**Step 2:** Disconnect the vent line from the top of the contact column.

**Step 3:** Remove the bolts in the 6" base flange.

**Step 4:** Remove the column, lifting it over the interior riser tube.

**Step 5:** Remove and clean the diffuser.

**Step 6:** Inspect the flange gasket and replace if necessary.

**Step 7:** Reassemble the contact column and attach vent lines.

# Reaction Chamber – Exploded View

Figure 17

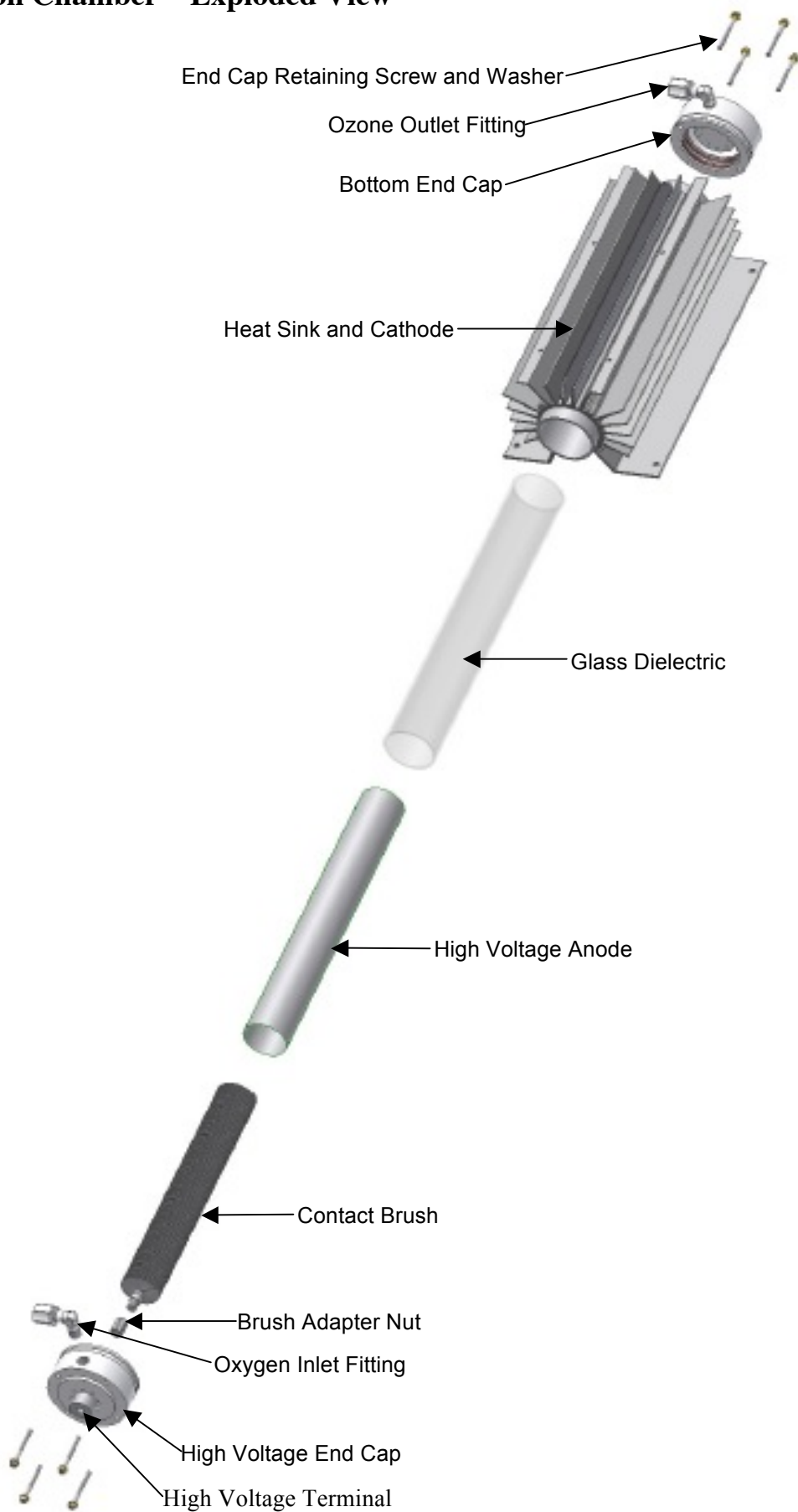

# Troubleshooting

## Air Preparation

<b>Problem/Symptom</b>	<b>Possible Cause</b>	<b>Solution</b>
Unit not operating	<ul style="list-style-type: none"> <li>No power to Ozone system</li> <li>Incorrect wiring to the Ozone system</li> <li>Main Power switch is in the "OFF" position</li> <li>Compressor not functioning</li> </ul>	<ul style="list-style-type: none"> <li>Check main power to system</li> <li>See "Installation Procedures – Electrical"</li> <li>Turn Main Power switch to the "ON" position</li> <li>Rebuild or replace as required</li> </ul>
Low air flow or no air flow (air preparation flow meter, bottom left-hand side of system)	<ul style="list-style-type: none"> <li>Flow meter out of adjustment</li> <li>Fouled compressor inlet filter</li> <li>Compressor not functioning</li> <li>Air leak</li> </ul>	<ul style="list-style-type: none"> <li>Adjust flow meter, see "Start-Up and Calibration – Step 10"</li> <li>Replace inlet filter</li> <li>Rebuild or replace as required</li> <li>Check &amp; tighten fittings</li> </ul>
Compressor pressure relief valve making noise	<ul style="list-style-type: none"> <li>Pressure relief valve not operating</li> <li>Pinched tubing</li> <li>Compressor not functioning</li> <li>Sieve bed (ATF) not operating</li> </ul>	<ul style="list-style-type: none"> <li>Replace pressure relief valve</li> <li>Replace tubing</li> <li>Rebuild or replace as required</li> <li>Repair or replace ATF as required</li> </ul>
Fan not operating (bottom right-hand side of the system)	<ul style="list-style-type: none"> <li>Debris caught in fan</li> <li>Fan inoperable</li> </ul>	<ul style="list-style-type: none"> <li>Remove debris</li> <li>Replace fan</li> </ul>

## Electrical Interlock Box

<b>Problem/Symptom</b>	<b>Possible Cause</b>	<b>Solution</b>
'Feed Gas Flow Rate' meter out of adjustment (Control Panel)	<ul style="list-style-type: none"> <li>No feed gas flow rate</li> <li>High feed gas flow rate</li> <li>Low feed gas flow rate</li> </ul>	<ul style="list-style-type: none"> <li>Air preparation system not operating correctly. See air preparation section above.</li> <li>Make adjustments to the flow meter on the electrical interlock box.</li> </ul>
Vacuum Gauge not within operating parameters (Electrical Interlock Box). Vacuum too high	<ul style="list-style-type: none"> <li>High vacuum</li> </ul>	<ul style="list-style-type: none"> <li>Gradually open the ball valve on the injector manifold. See Startup and Calibration.</li> </ul>
Vacuum Gauge not within operating parameters (Electrical Interlock Box). Vacuum too low	<ul style="list-style-type: none"> <li>Low vacuum</li> <li>Defective injector check valve</li> <li>No water in vacuum break</li> <li>Off-gas vent restricted</li> <li>Defective O-ring seals in reaction chambers</li> <li>Loose internal fittings</li> <li>Defective dielectrics</li> <li>Defective solenoid</li> <li>Defective vacuum gauge</li> </ul>	<ul style="list-style-type: none"> <li>Gradually close the ball valve on the injector manifold. See Startup and Calibration.</li> <li>Replace injector check valve</li> <li>Fill vacuum break with water, see 'Start Up &amp; Calibration'</li> <li>Clean Off-gas Vent</li> <li>Check and replace as required</li> <li>Check all fittings tighten as required</li> <li>Check and replace as required</li> <li>Inspect and repair/replace as necessary</li> <li>Replace vacuum gauge</li> </ul>
Unit does not stay on	<ul style="list-style-type: none"> <li>Insufficient Vacuum (should be -3 to -8 in Hg)</li> <li>Unit Overheating</li> </ul>	<ul style="list-style-type: none"> <li>See Vacuum Gauge not within operating parameters above</li> <li>Clean fan filter, check fan</li> </ul>



**Electrical Interlock Box - Continued**

<b>Problem/Symptom</b>	<b>Possible Cause</b>	<b>Solution</b>
Unit cycles on and off	<ul style="list-style-type: none"> <li>• Unit Overheating</li> <li>• Defective Power</li> <li>• Defective Solenoid</li> <li>• System neutral not a true neutral</li> </ul>	<ul style="list-style-type: none"> <li>• Clean fan filter, check fan</li> <li>• Check for constant power if not timer controlled</li> <li>• Inspect and repair/replace as necessary</li> <li>• Connect a true neutral to the interlock box, confirm no voltage reading between neutral and ground.</li> </ul>
Flow meter will not adjust	<ul style="list-style-type: none"> <li>• Air preparation not operating</li> <li>• Defective solenoid</li> <li>• Defective check valve</li> </ul>	<ul style="list-style-type: none"> <li>• Make sure air preparation system is set properly (see Startup and Calibration)</li> <li>• Inspect and repair or replace solenoid</li> <li>• Check and replace check valve</li> </ul>
“Main Power” light not on	<ul style="list-style-type: none"> <li>• No power to electrical interlock box</li> <li>• No neutral in 120 VAC supply</li> <li>• Light burnt out</li> </ul>	<ul style="list-style-type: none"> <li>• Check power connections and breakers</li> <li>• Hook up neutral</li> <li>• Replace Bulb</li> </ul>
“MCI” light not on	<ul style="list-style-type: none"> <li>• 120 VAC signal not connected to terminal #4</li> <li>• Light burnt out</li> <li>• No neutral in 120 VAC supply</li> </ul>	<ul style="list-style-type: none"> <li>• Jumper terminal #1 to #4</li> <li>• Replace bulb</li> <li>• Hook up neutral</li> </ul>
“VACUUM SYSTEM” light not on	<ul style="list-style-type: none"> <li>• No power to electrical interlock box</li> <li>• No MCI</li> <li>• No neutral in 120VAC supply</li> <li>• No vacuum</li> <li>• Light burnt out</li> </ul>	<ul style="list-style-type: none"> <li>• Check power connection and breakers</li> <li>• Jumper terminal #1 to #4</li> <li>• Hook up neutral</li> <li>• Adjust injector vacuum (see Startup and Calibration)</li> <li>• Check tubing for leaks</li> <li>• Check booster pump operation</li> <li>• Turn power switch to “OFF” and then back to reset</li> <li>• Replace bulb</li> </ul>
“ORP” light not on	<ul style="list-style-type: none"> <li>• No power to electrical interlock box</li> <li>• No MCI</li> <li>• No neutral in 120VAC supply</li> <li>• No vacuum</li> <li>• System set to “MANUAL”</li> <li>• No 120VAC power to terminals #5 and #6</li> <li>• ORP level in excess of preset level</li> <li>• Light burnt out</li> </ul>	<ul style="list-style-type: none"> <li>• Check power connection and breakers</li> <li>• Jumper terminal #1 to #4</li> <li>• Hook up neutral</li> <li>• Adjust injector vacuum (see Startup and Calibration)</li> <li>• Check tubing for leaks</li> <li>• Check booster pump operation</li> <li>• Turn power switch to “OFF” and then back to reset</li> <li>• Switch to “AUTO”</li> <li>• Hook up power to these terminals (See Installation Procedures – Electrical)</li> <li>• Check input signal</li> <li>• Replace bulb</li> </ul>

### M-15/O<sub>2</sub> and P-20/O<sub>2</sub> Ozone Generator

<b>Problem/Symptom</b>	<b>Possible Cause</b>	<b>Solution</b>
Fan not operating	<ul style="list-style-type: none"> <li>• Fan obstructed</li> <li>• Fan inoperable</li> </ul>	<ul style="list-style-type: none"> <li>• Remove obstruction</li> <li>• Replace fan</li> </ul>
Unit flooded with water	<ul style="list-style-type: none"> <li>• Defective check valve</li> <li>• Vacuum break flapper valve stuck</li> <li>• Hydraulics out of adjustment</li> </ul>	<ul style="list-style-type: none"> <li>• Assess damage, repair as required, replace check valve</li> <li>• See ‘Maintenance Procedure’ – Annual</li> <li>• See ‘Startup &amp; Calibration’</li> </ul>
Ozone smell detected from or near ozone generator	<ul style="list-style-type: none"> <li>• Insufficient vacuum at venturi</li> <li>• Loose internal fittings</li> <li>• Defective O-ring seals in reaction chamber</li> <li>• Defective dielectrics</li> </ul>	<ul style="list-style-type: none"> <li>• See ‘Startup &amp; Calibration’</li> <li>• Check all fittings, tighten as required</li> <li>• Check &amp; replace as required</li> <li>• Check &amp; replace as required</li> </ul>
Main Power, “Red” LED not illuminated	<ul style="list-style-type: none"> <li>• No power to drive module from power supply</li> <li>• Blow fuse</li> <li>• Defective Drive Module</li> </ul>	<ul style="list-style-type: none"> <li>• Check main power to unit</li> <li>• Test voltage from power supply to drive module, see Appendix E</li> <li>• Replace Fuse</li> <li>• Replace Drive Module</li> </ul>
You suspect that no ozone is being produced	<ul style="list-style-type: none"> <li>• Drive Module Failure</li> <li>• Dielectric failure</li> </ul>	<ul style="list-style-type: none"> <li>• Touch the transformer, replace if not warm</li> <li>• Inspect and replace if necessary</li> </ul>

### CD15/O<sub>2</sub> and CD20/O<sub>2</sub> Ozone Generator

<b>Problem/Symptom</b>	<b>Possible Cause</b>	<b>Solution</b>
Fan not operating	<ul style="list-style-type: none"> <li>• Fan obstructed</li> <li>• Fan inoperable</li> </ul>	<ul style="list-style-type: none"> <li>• Remove obstruction</li> <li>• Replace fan</li> </ul>
Unit flooded with water	<ul style="list-style-type: none"> <li>• Defective check valve</li> <li>• Vacuum break flapper valve stuck</li> <li>• Hydraulics out of adjustment</li> </ul>	<ul style="list-style-type: none"> <li>• Assess damage, repair as required, replace check valve</li> <li>• See ‘Maintenance Procedure’ – Annual</li> <li>• See ‘Startup &amp; Calibration’</li> </ul>
Ozone smell detected from or near ozone generator	<ul style="list-style-type: none"> <li>• Insufficient vacuum at venturi</li> <li>• Loose internal fittings</li> <li>• Defective O-ring seals in reaction chamber</li> <li>• Defective dielectrics</li> </ul>	<ul style="list-style-type: none"> <li>• See ‘Startup &amp; Calibration’</li> <li>• Check all fittings, tighten as required</li> <li>• Check &amp; replace as required</li> <li>• Check &amp; replace as required</li> </ul>
12V Main Power, “Green” LED not illuminated	<ul style="list-style-type: none"> <li>• No power to drive module from power supply</li> </ul>	<ul style="list-style-type: none"> <li>• Check main power to unit</li> <li>• Test voltage from power supply to drive module, see Appendix E</li> </ul>
Transformer (XFMR) Power, “Green” LED not illuminated	<ul style="list-style-type: none"> <li>• If drive board “Main Power” LED is not illuminated, the “XFMR Power” LED will not illuminate</li> <li>• Blown drive board “on board” fuse</li> <li>• Drive board is in “Fault” mode</li> </ul>	<ul style="list-style-type: none"> <li>• Test voltage from power supply to drive module, see Appendix E</li> <li>• Replace “on board” fuse</li> <li>• See Troubleshooting, “Fault” LED</li> </ul>

**CD15/O<sub>2</sub> and CD20/O<sub>2</sub> Ozone Generator**- Continued

<b>Problem/Symptom</b>	<b>Possible Cause</b>	<b>Solution</b>
Ozone Output, “Amber” LED not illuminated	<ul style="list-style-type: none"> <li>• If the Transformer (XFMR) Power LED is not illuminated, the “Ozone Output” LED will not illuminate</li> <li>• The Manual Ozone Output potentiometer is turned down to 0%</li> <li>• Remote4-20mA Controller is sending a 4mA signal, which limits output to 0%</li> <li>• Drive board is in “Fault” mode</li> </ul>	<ul style="list-style-type: none"> <li>• Check all wires and connectors</li> <li>• See ‘Installation Procedures’ – Electrical</li> <li>• No solution required, controller will adjust LED automatically</li> <li>• See Troubleshooting, “Fault” LED</li> </ul>
The “Ozone Output” LED not responding to the remote 4-20mA control signal	<ul style="list-style-type: none"> <li>• The remote 4-20mA control signal is not sensed by the 4-20mA control board</li> <li>• Insufficient voltage on 4-20mA control signal</li> </ul>	<ul style="list-style-type: none"> <li>• Check for loose wires or connections</li> <li>• See ‘Installation Procedures’ – Electrical</li> <li>• Check 4-20mA controller operation</li> <li>• Insure at least 6.5 VDC is present on the 4-20mA control signal to enable remote control. A signal booster is available is needed, part number OZD420.</li> </ul>
System Fault – Single Flash The drive board can not get enough power into the reaction chamber.	<ul style="list-style-type: none"> <li>• Loose wire harness connection from the drive board to the drive transformer</li> <li>• Drive board incorrectly characterized the system on startup</li> <li>• Loose or disconnected High Voltage Lead to transformer</li> <li>• Excessive dirt or debris in ozone reaction chamber</li> <li>• Water in ozone reaction chamber</li> <li>• Broken dielectric</li> <li>• Failed drive board</li> <li>• Failed drive transformer</li> </ul>	<ul style="list-style-type: none"> <li>• Check all wires and connectors</li> <li>• With pressure and flow at normal operating conditions, restart the ozone generator.</li> <li>• Attach High Voltage Lead to transformer</li> <li>• Clean the dielectric and replace O-rings</li> <li>• Clean the dielectric and replace O-rings</li> <li>• Replace dielectric</li> <li>• Replace drive board</li> <li>• Replace drive transformer</li> </ul>
System Fault – Double Flash The drive board’s feedback had a series of sudden dips indicative of unusual arcing occurring somewhere in the system.	<ul style="list-style-type: none"> <li>• Loose wire harness connection from the drive board to the drive transformer</li> <li>• Loose or disconnected High Voltage Lead to transformer</li> <li>• Excessive dirt or debris in ozone reaction chamber</li> <li>• Water in ozone reaction chamber</li> <li>• Broken dielectric</li> <li>• Failed drive board</li> <li>• Failed drive transformer</li> </ul>	<ul style="list-style-type: none"> <li>• Check all wires and connectors</li> <li>• Attach High Voltage Lead to transformer</li> <li>• Clean the dielectric and replace O-rings</li> <li>• Clean the dielectric and replace O-rings</li> <li>• Replace dielectric</li> <li>• Replace drive board</li> <li>• Replace drive transformer</li> </ul>
System Fault – Triple Flash The thermal switch on the board has closed indicating that it was exposed to temperatures exceeding 140F.	<ul style="list-style-type: none"> <li>• Unit is overheating</li> </ul>	<ul style="list-style-type: none"> <li>• Check fan for proper operation and clean fan filter</li> <li>• Check operating temperature</li> <li>• See “Installation Procedures – Getting Started, Equipment Placement”</li> </ul>

**CD15/O<sub>2</sub> and CD20/O<sub>2</sub> Ozone Generator- Continued**

<b>Problem/Symptom</b>	<b>Possible Cause</b>	<b>Solution</b>
You suspect that no ozone is being produced	<ul style="list-style-type: none"> <li>• Drive Module Failure</li> <li>• Dielectric failure</li> </ul>	<ul style="list-style-type: none"> <li>• Touch the transformer, replace if not warm</li> <li>• Inspect and replace if necessary</li> </ul>

**General System**

<b>Problem/Symptom</b>	<b>Possible Cause</b>	<b>Solution</b>
Unit trips circuit breaker	<ul style="list-style-type: none"> <li>• Incorrect wiring</li> <li>• Incorrect circuit breaker</li> </ul>	<ul style="list-style-type: none"> <li>• Check wiring (see Installation Procedures – Electrical)</li> <li>• Replace with correct circuit breaker</li> </ul>
You receive an electrical shock upon touching the unit	<ul style="list-style-type: none"> <li>• Incorrect wiring</li> <li>• Unit not grounded</li> <li>• Unit has been flooded</li> </ul>	<ul style="list-style-type: none"> <li>• Check wiring (see Installation Procedures – Electrical)</li> <li>• Ground unit (see Installation Procedures – Electrical)</li> <li>• Return unit for major service or completely disassemble and clean</li> </ul>
Water in unit or ozone delivery tubing	<ul style="list-style-type: none"> <li>• Insufficient vacuum</li> <li>• Defective check valve(s)</li> <li>• Excessive back pressure on check valve</li> </ul>	<ul style="list-style-type: none"> <li>• Adjust injector vacuum (see Startup and Calibration)</li> <li>• Replace check valve(s)</li> <li>• Back pressure not to exceed 40psi – if over 40 psi consult ClearWater Tech distributor</li> </ul>

**Ozone Injection/Contacting/Vacuum Break**

<b>Problem/Symptom</b>	<b>Possible Cause</b>	<b>Solution</b>
Water backflow past injector check valve	<ul style="list-style-type: none"> <li>• Defective injector check valve</li> </ul>	<ul style="list-style-type: none"> <li>• Replace injector check valve</li> </ul>
Water bubbling in vacuum break	<ul style="list-style-type: none"> <li>• Insufficient ‘Ozone Injector – Vacuum’</li> <li>• Debris on seat of vacuum break flapper valve</li> </ul>	<ul style="list-style-type: none"> <li>• See “Startup and Calibration”</li> <li>• Clean seat of flapper. See “Maintenance Procedures – Annual”</li> </ul>
No vacuum at venture inlet port of ozone injector	<ul style="list-style-type: none"> <li>• Low gpm water flow through ozone injector</li> <li>• Back pressure in hydraulic line</li> <li>• Booster pump not functioning properly</li> </ul>	<ul style="list-style-type: none"> <li>• Check for obstruction upstream</li> <li>• Check for obstructions downstream of ozone injector</li> <li>• Check booster pump (contact dealer)</li> </ul>
Ozone smell detected in or around vacuum break or ozone injector	<ul style="list-style-type: none"> <li>• Insufficient vacuum at venturi</li> <li>• Loose fittings</li> <li>• Broken fittings</li> </ul>	<ul style="list-style-type: none"> <li>• See ‘Startup &amp; Calibration’</li> <li>• Check all fittings, tighten as required</li> </ul>
Outlet water Supply Pressure Relief Valve is relieving water	<ul style="list-style-type: none"> <li>• ‘Low Pressure – Side Water’ gauge is in excess of 55 PSI. Inlet water supply pressure is high</li> <li>• Excessive back pressure downstream of Ozone system</li> </ul>	<ul style="list-style-type: none"> <li>• Reduce inlet water supply pressure to no more than 20 PSI</li> <li>• Pressure downstream of the Ozone system must not exceed inlet water supply pressure or 20 PSI</li> </ul>

# Appendix A – Specifications

## Air Preparation System (Aerous 15 Shown)

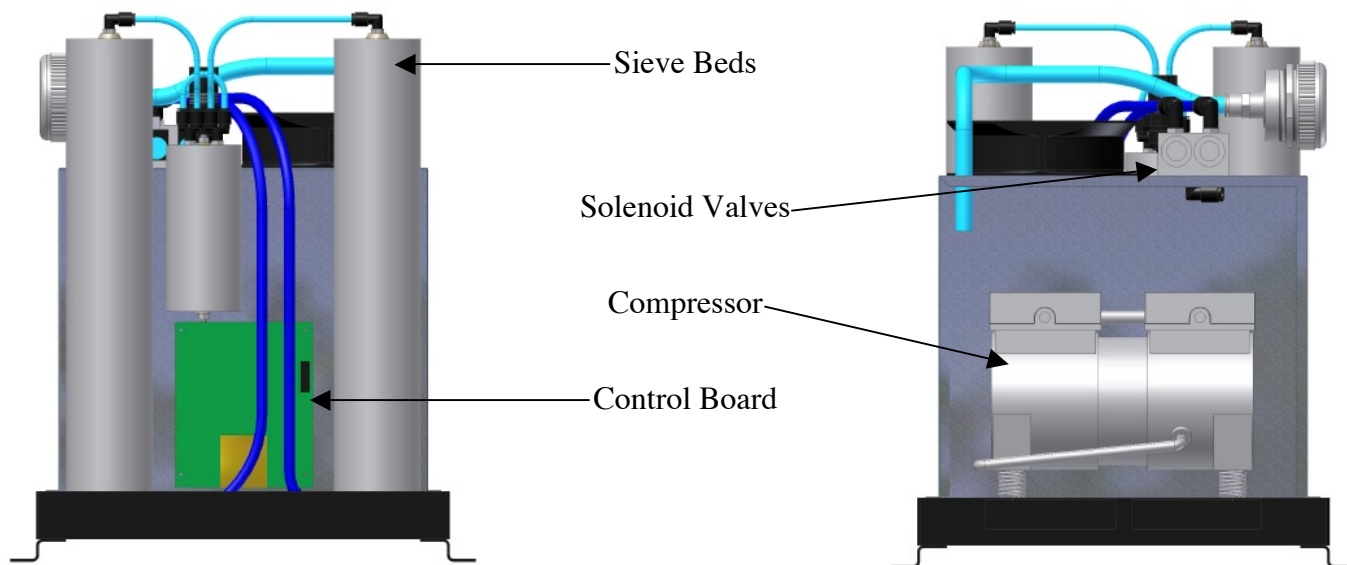
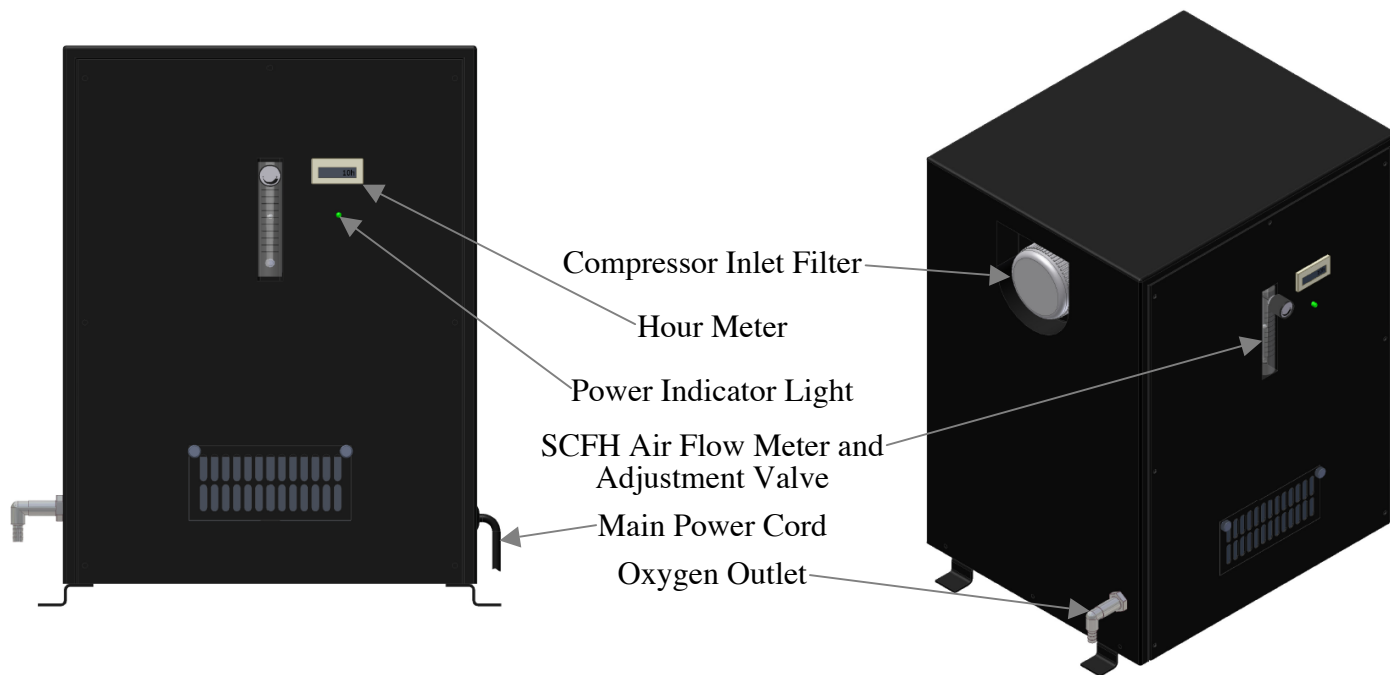

Air Prep System	Oxygen Output/SCFH
M-15/O <sub>2</sub> and CD15/O <sub>2</sub> (Aerous 8)	90% (+/-3%) @ 8 scfh, 10 PSI
P-20/O <sub>2</sub> and CD20/O <sub>2</sub> (Aerous 15)	90% (+/-3%) @ 15 scfh, 10 PSI

**Air Preparation System (Workhorse 12C Shown)**

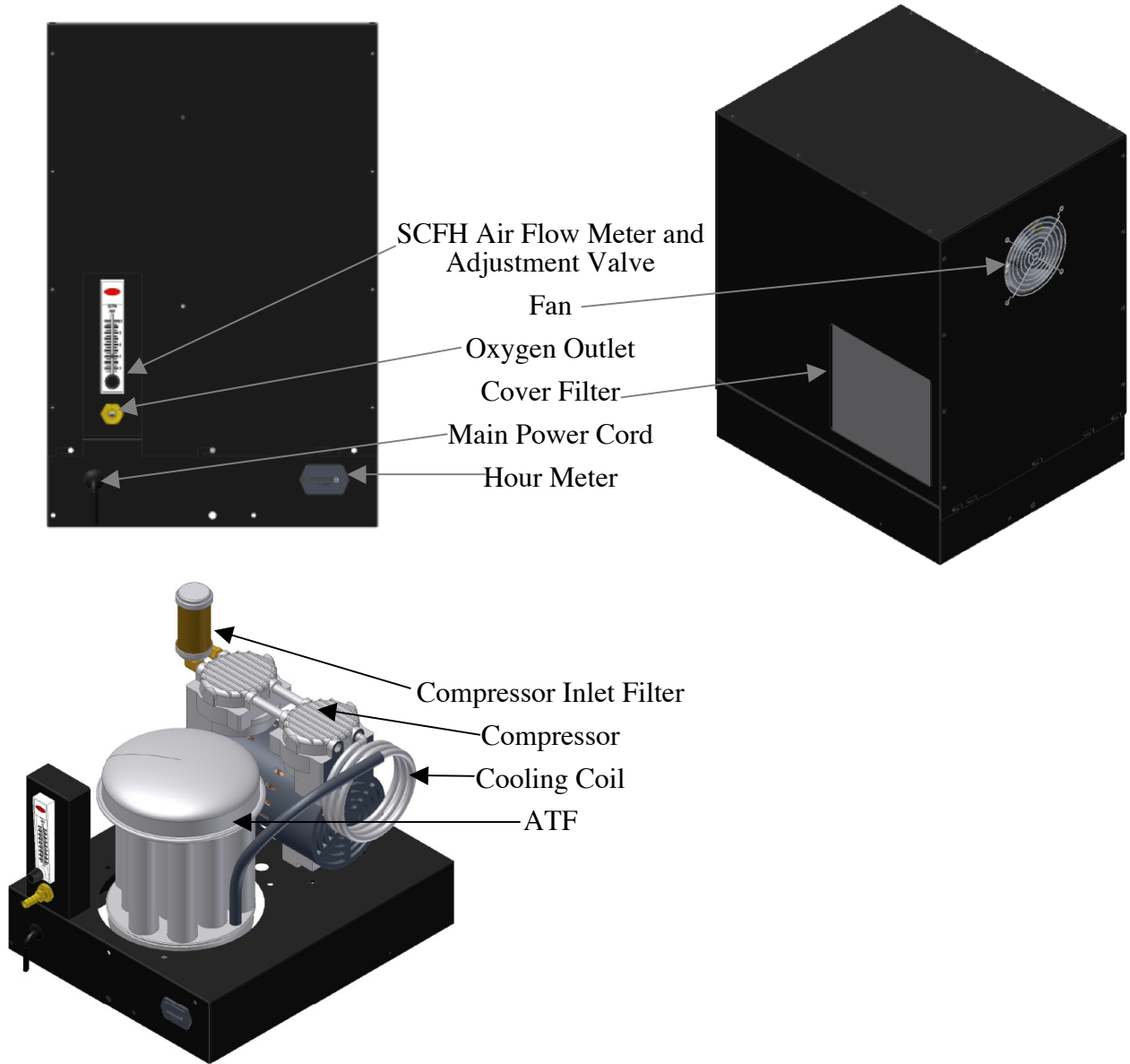

Air Prep System	Oxygen Output/SCFH
M-15/O <sub>2</sub> and CD15/O <sub>2</sub> (Workhorse 8C)	90% (+/-3%) @ 8 scfh, 5PSI
P-20/O <sub>2</sub> and CD20/O <sub>2</sub> (Workhorse15C)	90% (+/-3%) @ 15 scfh, 5PSI

**Electrical Interlock Box**

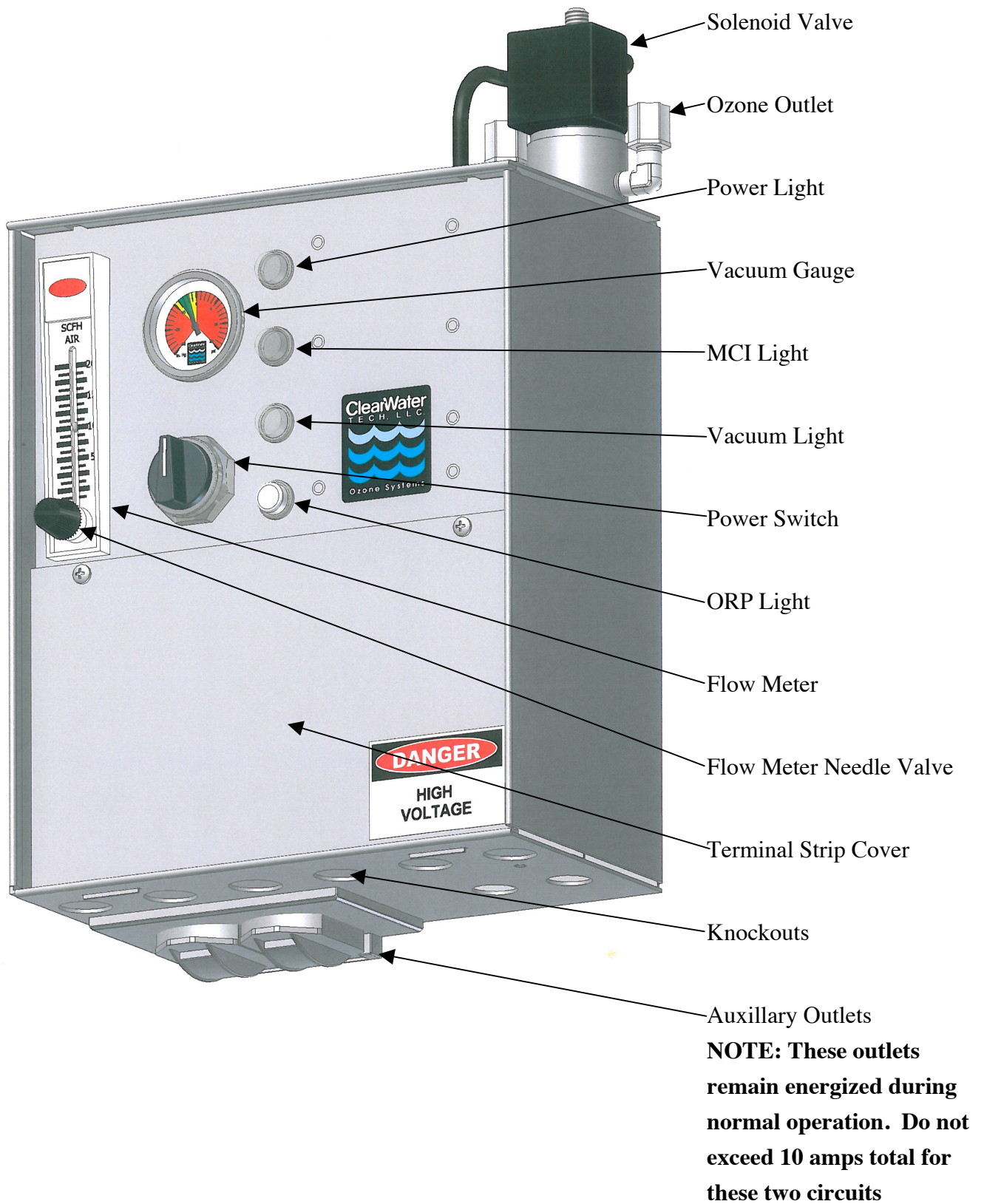



**M-15/O<sub>2</sub>**

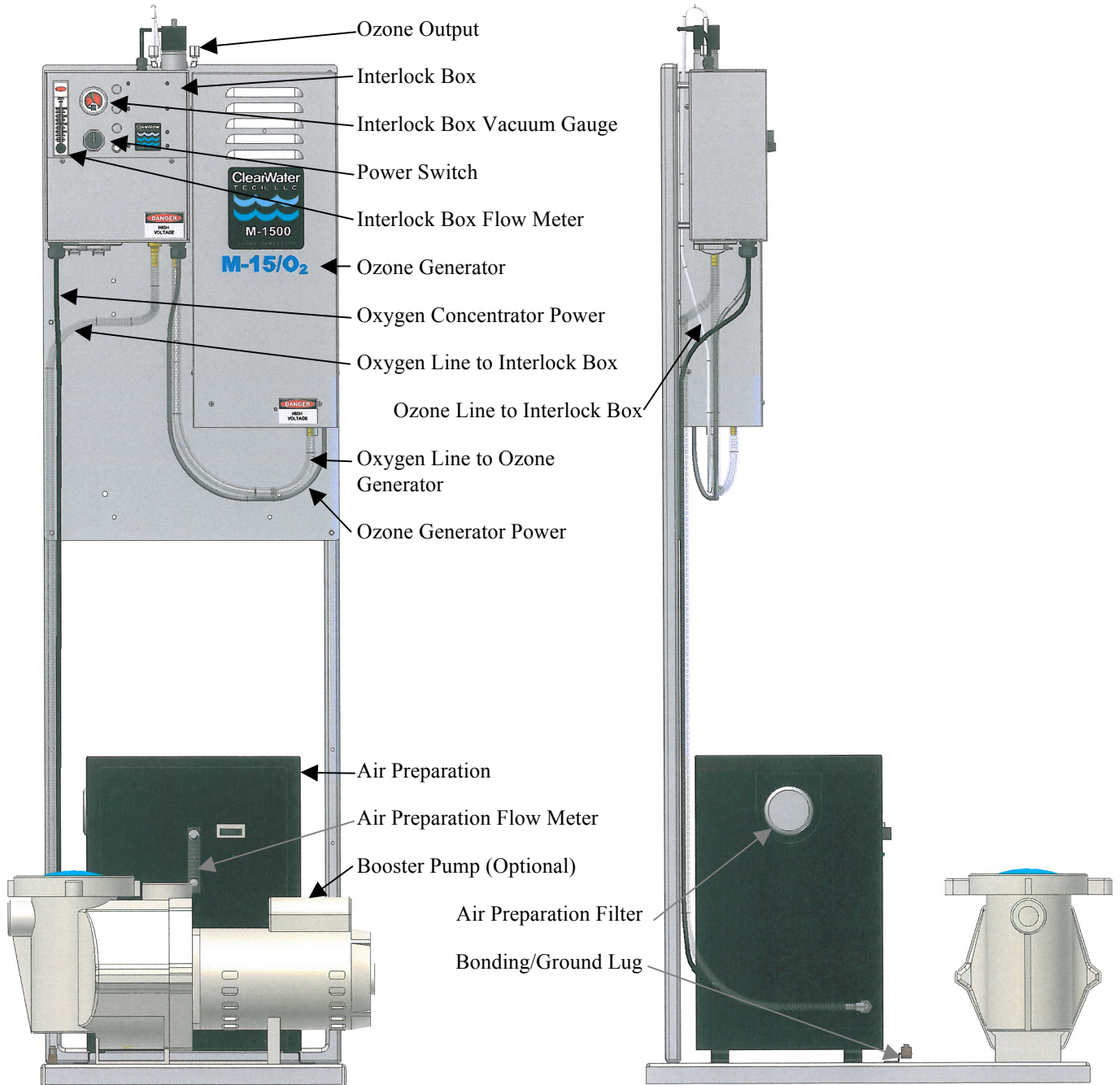

Shown: M-15/O<sub>2</sub> with Areous Oxygen Generator and Wisperflow Booster Pump

Ozone Generator	Specifications	Ozone Output
M-15/O <sub>2</sub>	72" h x 26" w x 29" d, 210 lbs	7.6 g/h @ 7 SCFH



# M1500 – Ozone Generator

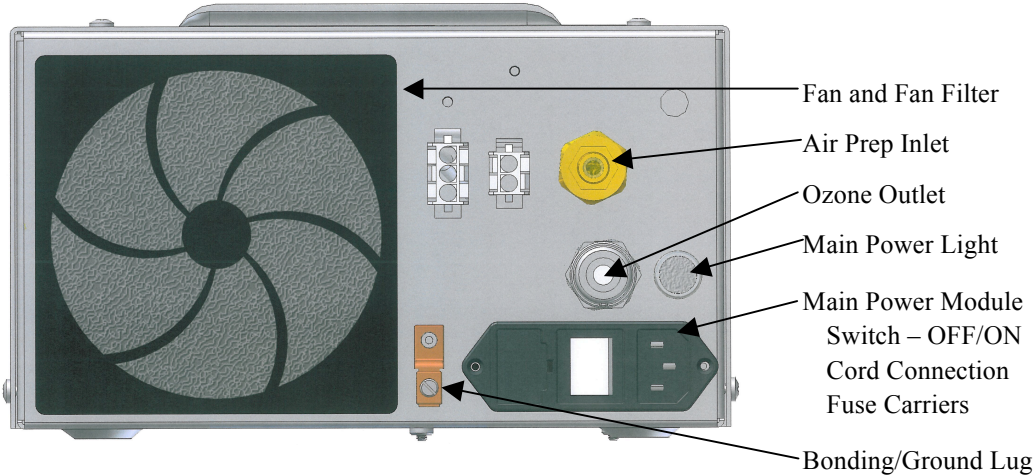
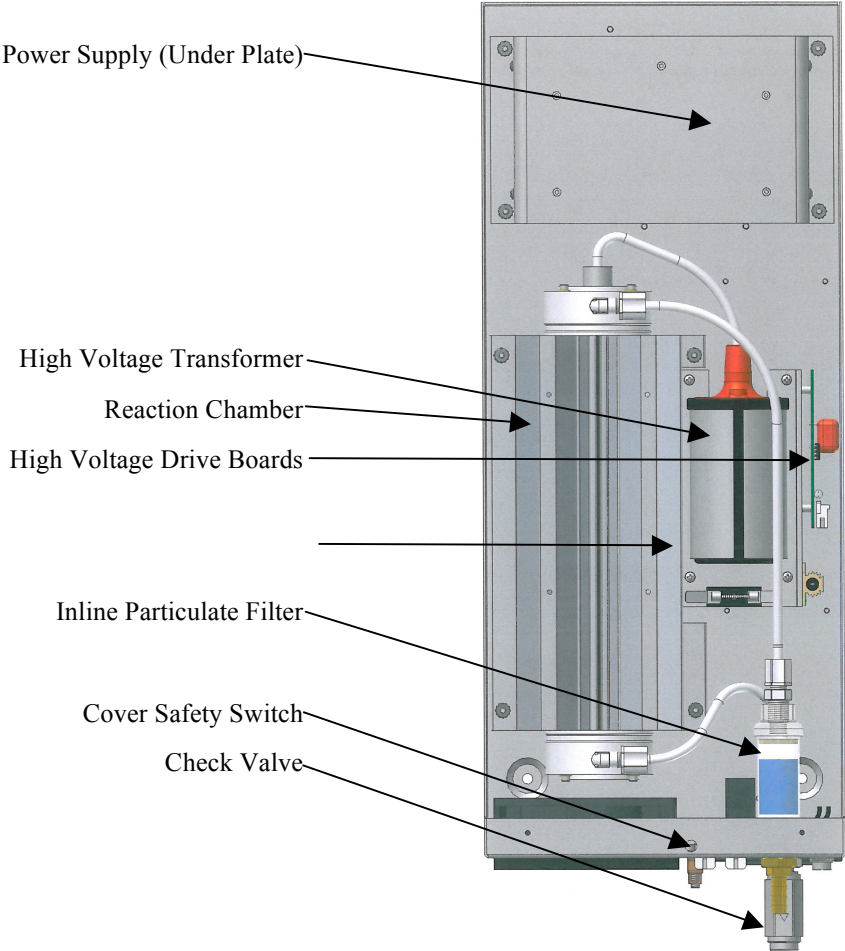
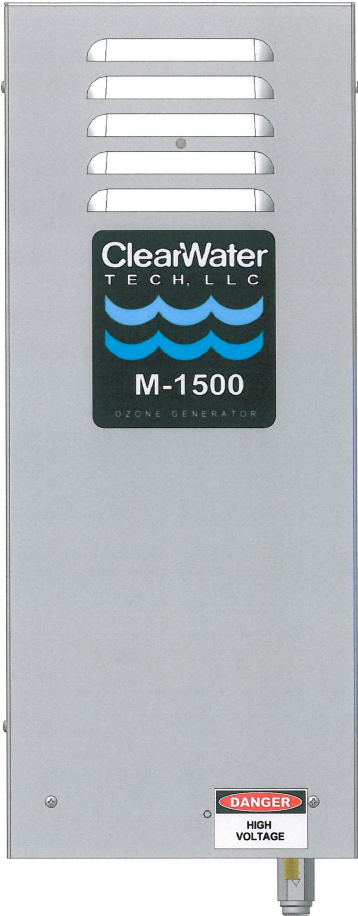

CD15/O<sub>2</sub>

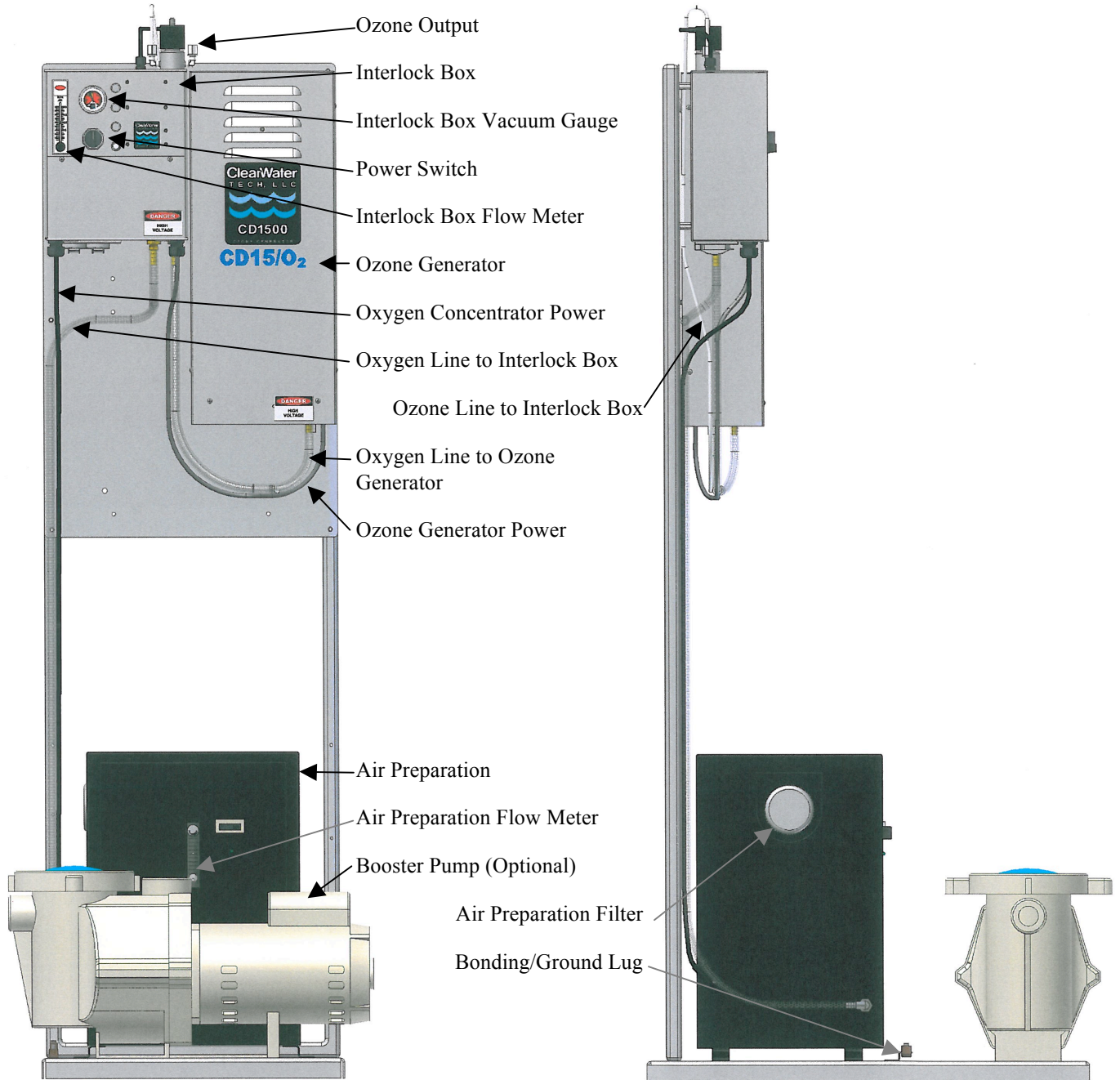

Shown: CD15/O<sub>2</sub> with Areous Oxygen Generator and Wisperflow Booster Pump

Ozone Generator	Specifications	Ozone Output
CD15/O <sub>2</sub>	72" h x 26" w x 29" d, 210 lbs	10 g/h @ 7 SCFH



# CD1500 – Ozone Generator

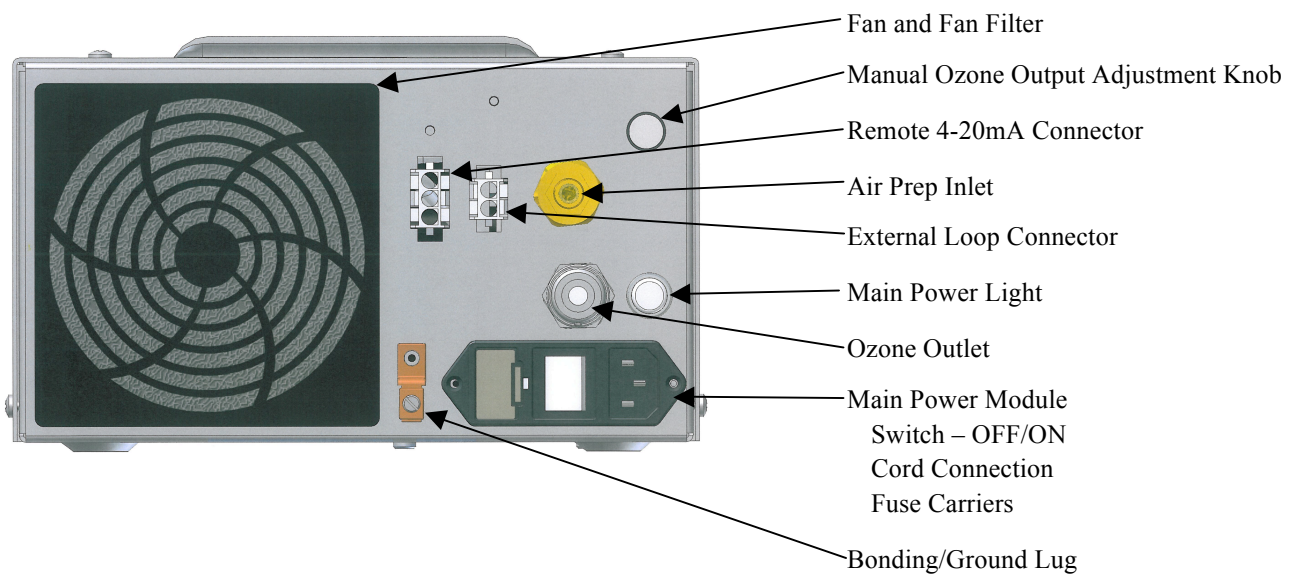
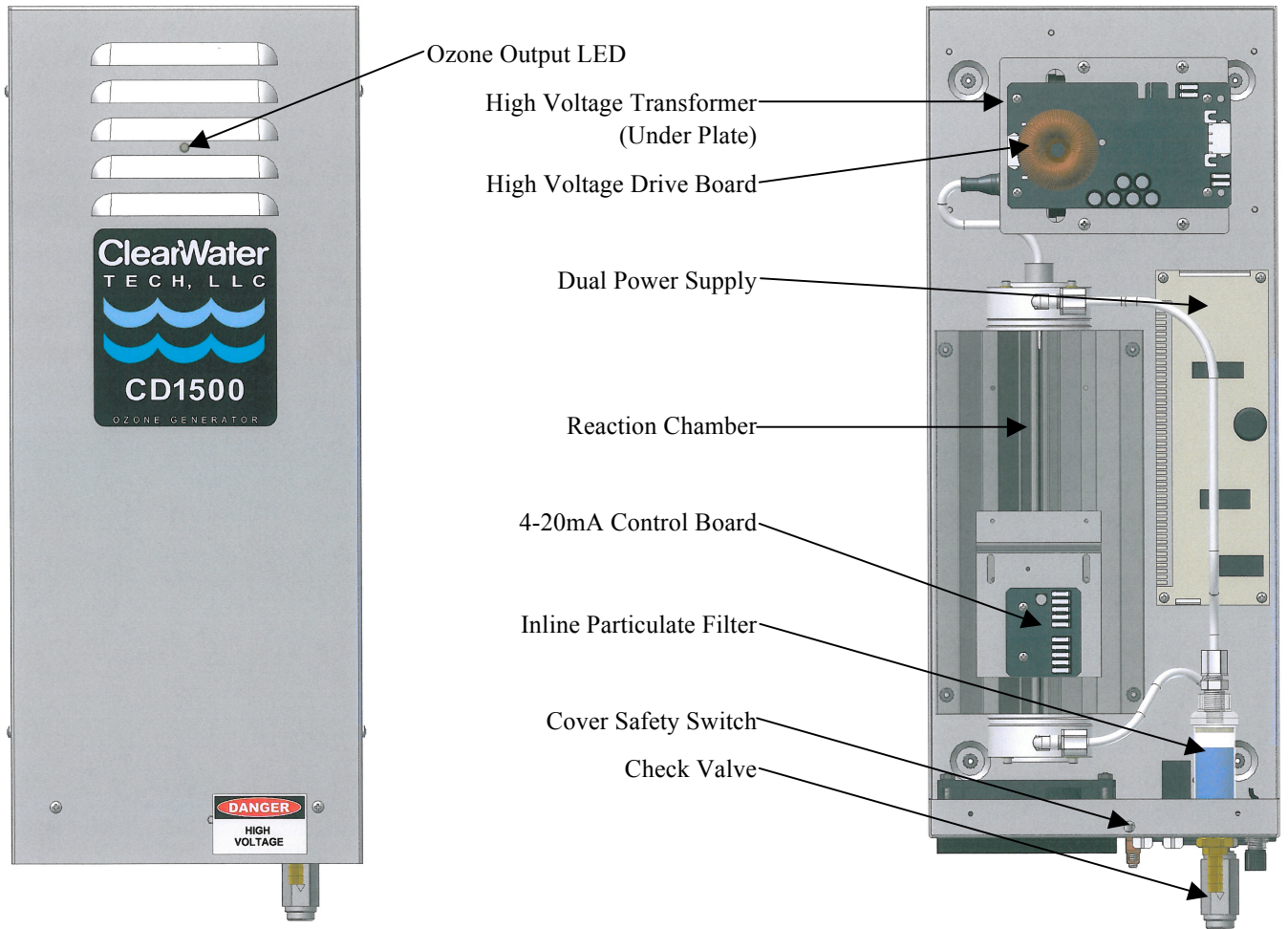

**P-20/O<sub>2</sub>**

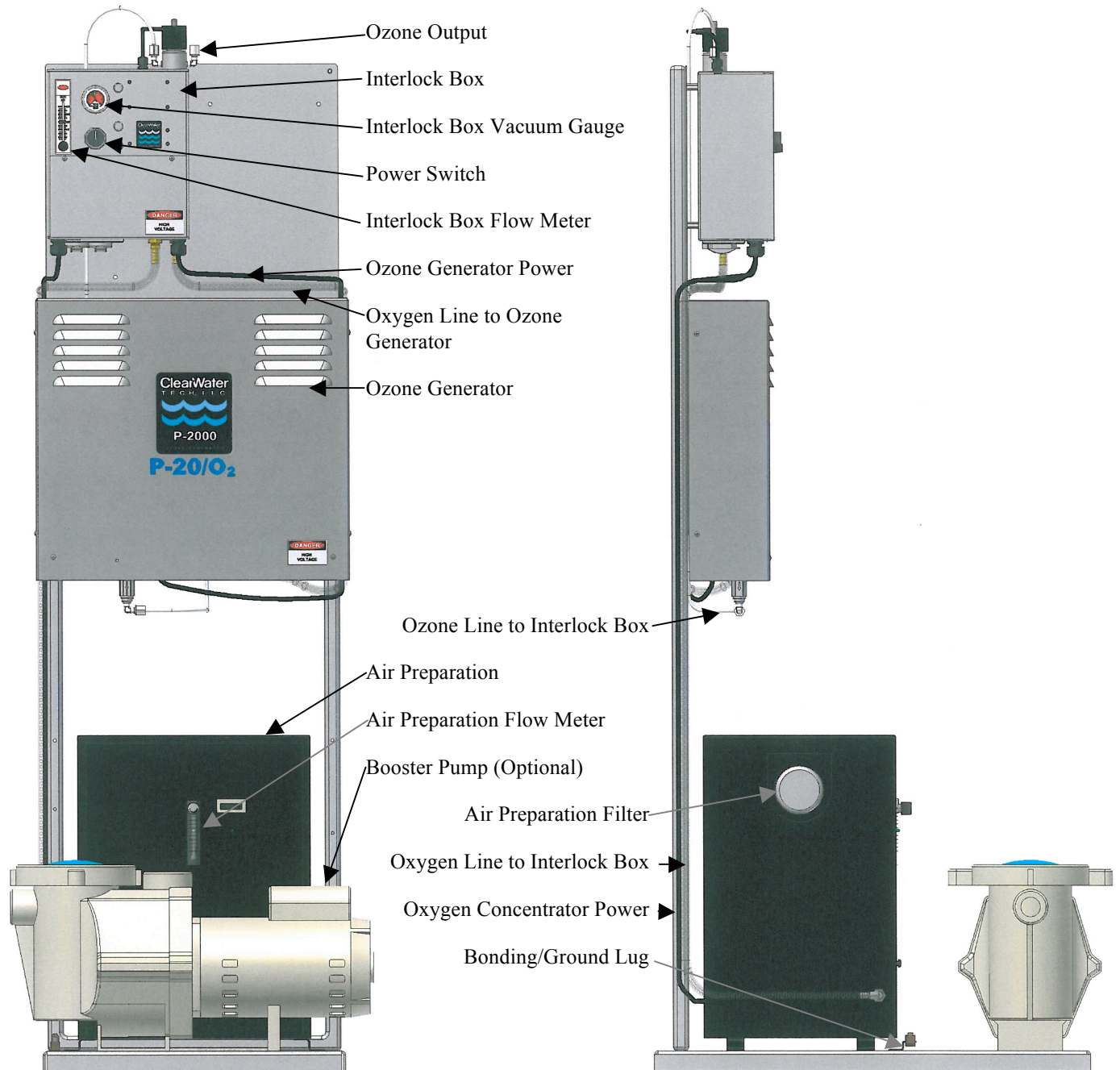

Shown: P-20/O<sub>2</sub> with Areous Oxygen Generator and Wisperflow Booster Pump

Ozone Generator	Specifications	Ozone Output
P-20/O <sub>2</sub>	72" h x 26" w x 29" d, 210 lbs	14 g/h @ 14 SCFH



**P2000 – Ozone Generator**

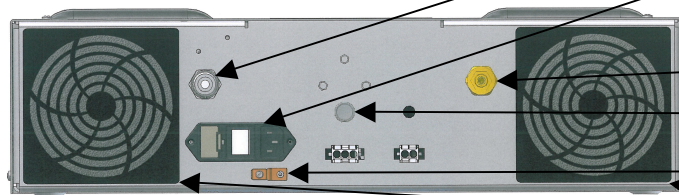
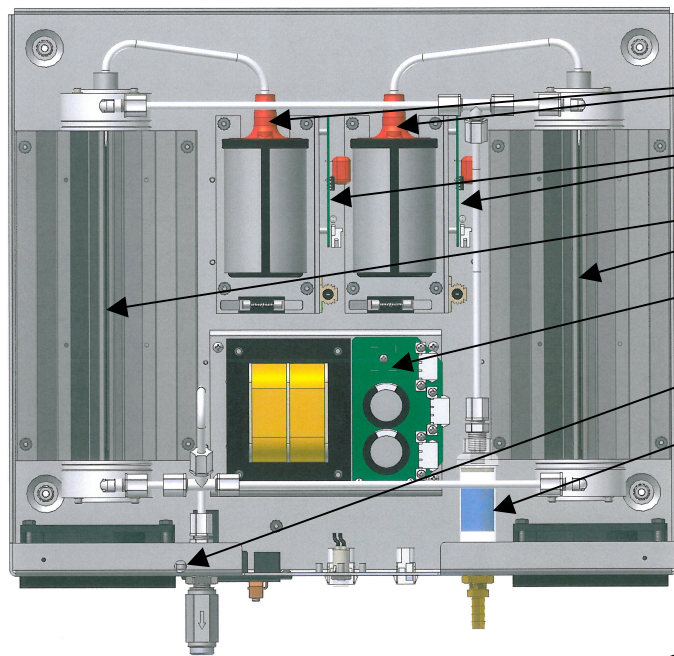
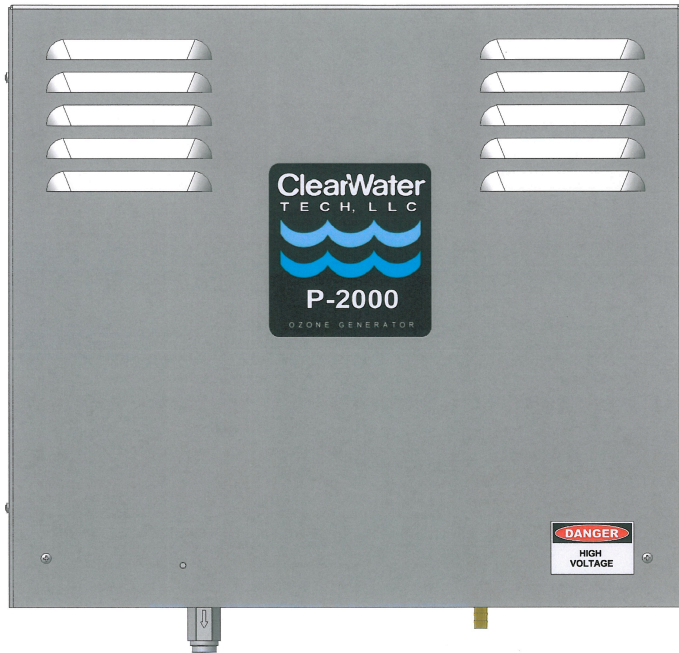

- Drive Transformer
- Drive Boards
- Reaction Chambers
- Power Supply
- Cover Safety Switch
- Inline Particulate Filter
- Ozone Outlet
- Main Power Module Switch – OFF/ON
- Cord Connection
- Fuse Carriers
- Air Prep Inlet
- Main Power Light
- Bonding/Ground Lug
- Fan and Fan Filter

CD20/O<sub>2</sub>

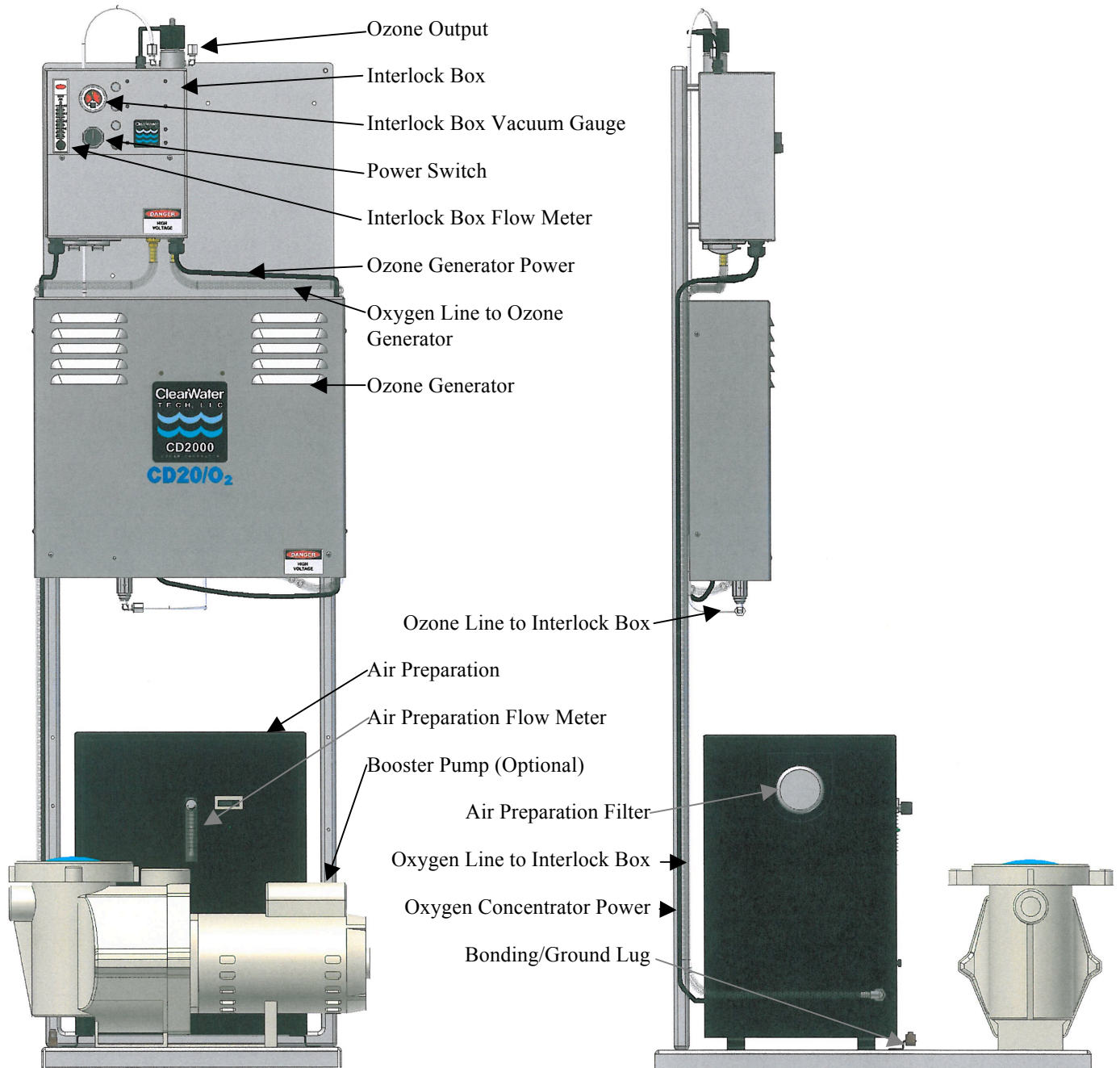

Shown: CD20/O<sub>2</sub> with Areous Oxygen Generator and Wisperflow Booster Pump

Ozone Generator	Specifications	Ozone Output
CD20/O <sub>2</sub>	72" h x 26" w x 29" d, 210 lbs	20 g/h @ 14 SCFH



**CD2000 – Ozone Generator**

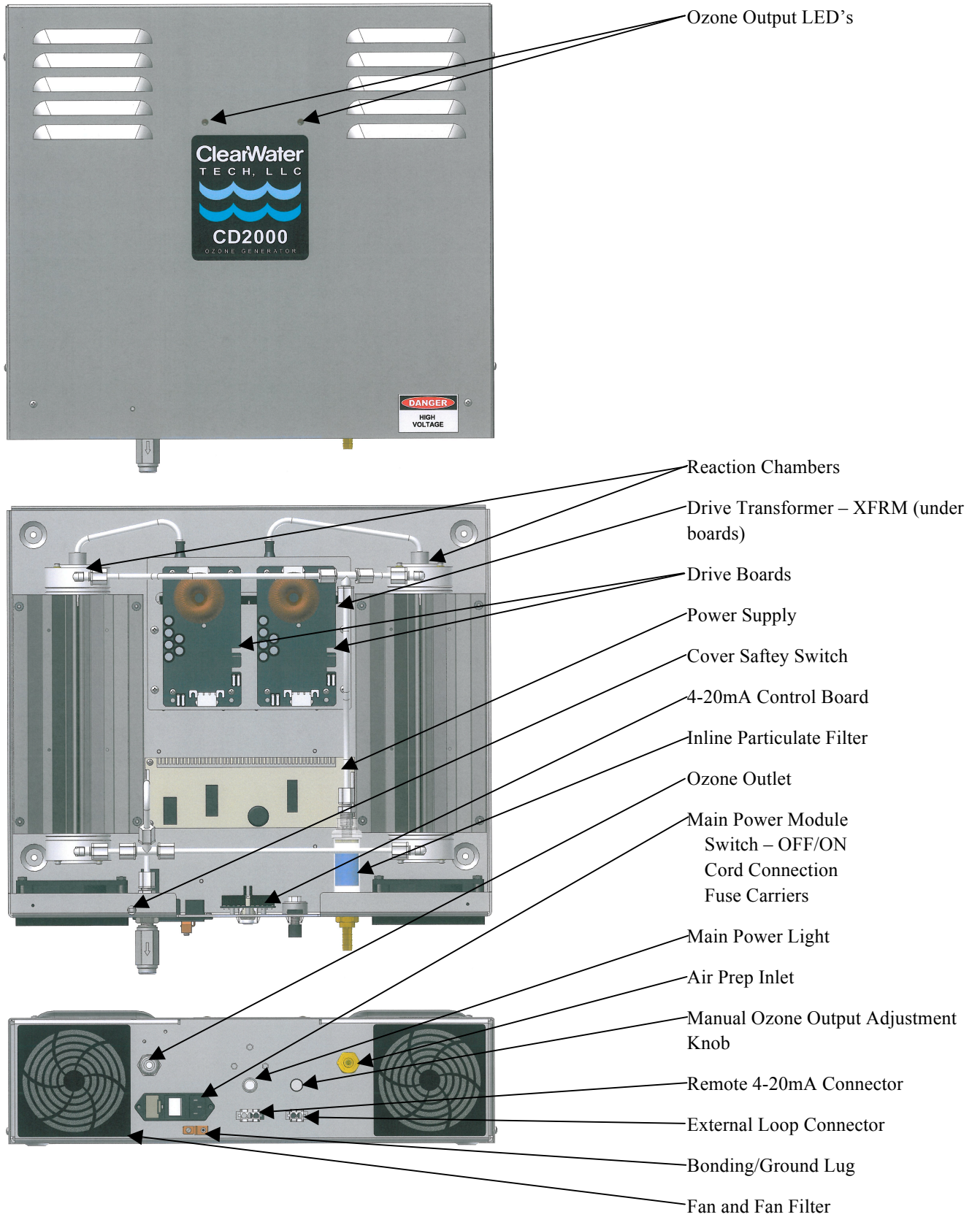

# Appendix B – Parts List

## Air Preparation System

<b>OXS90 Replacement Parts</b>	
<b>Description</b>	<b>Part Number</b>
Compressor Inlet Filter	OXS350
Compressor Rebuild Kit	OXS356
Pressure Relief Valve	OXS361
Compressor Vibration Mount	OXS365
Indicating Desiccant Refill (if so equipped)	DES16

## Air Preparation System

<b>Aerous Replacement Parts</b>	
<b>Description</b>	<b>Part Number</b>
Rebuild Kit – Aerous 8 – Sieve Beds and Solenoid Valve	ASP71A
Rebuild Kit – Aerous 15 – Sieve Beds and Solenoid Valve	ASP76A
Enclosure Filter - Aerous 8	OXS350
Enclosure Filter - Aerous 15	OXU351
Inlet Filter Package - Aerous 8 & 15	OXU371
Sieve Bed (Single) – Aerous 8	OXU375
Sieve Bed (Single) – Aerous 15	OXU381
Silencer – Aerous 8 & 15	OXU382
Solenoid Valve Assembly - Aerous 8 & 15	OXU379
Compressor – Aerous 8 120V 60Hz	OXU373
Compressor – Aerous 8 220/240V 50/60Hz	OXU374
Compressor – Aerous 15 120V 60Hz	OXU340
Compressor – Aerous 15 220/240V 50/60Hz	OXU345
Pressure Regulator – Aerous 8 & 15	OXU380
Output Storage Tank – Aerous 8 & 15	OXU384
Control Board – Aerous 8 120V 60Hz	OXU372
Control Board – Aerous 8 220/240V 50/60Hz	OXU386
Control Board – Aerous 15 120V 60Hz	OXU377
Control Board – Aerous 15 220/240V 50/60Hz	OXU378



**Ozone Generator**

<b>Ozone Generator Replacement Parts</b>	
<b>Description</b>	<b>Part Number</b>
Reaction Chamber – Complete	RCC6
Dielectric Anode 2”	RCC73SA
Non High Voltage End Cap	RCC107
High Voltage End Cap	RCC102
O-ring Set	ORS30
Drive Module - – M-15/O <sub>2</sub> and P-20/O <sub>2</sub>	DRM10
Drive Module Transformer – CD15/O <sub>2</sub> and CD20/O <sub>2</sub>	HVT275SA
Drive Module Board – CD15/O <sub>2</sub> and CD20/O <sub>2</sub>	CCA1232SA
Power Supply Board – Single CD15/O <sub>2</sub> and CD20/O <sub>2</sub>	PSR820
Power Supply - – M-15/O <sub>2</sub>	PS150
Power Supply – P-20/O <sub>2</sub>	PS300
Cooling Fan – 24VDC	FA46
Cooling Fan – 120V 50/60 Hz	FA41
Cooling Fan – 240V 50/60 Hz	FA42
Cooling Fan Filter	FA40
Inline Particulate Filter	FLT34
Fuse, Bussmann MDA-5 – 5 amp, 250VAC Slow Blow, Main Power	FUS20
Fuse, Littelfuse Minifuse 297005 – 5 amp, 32VAC, Drive Board	FUS75

**Interlock Box**

<b>Interlock Box Replacement Parts</b>	
<b>Description</b>	<b>Part Number</b>
Gauge – SCFH (0-20)	GAG370
Relay – Vacuum Time Delay	REL52
Vacuum Switch	SWT90SA
Gauge – PSI, Vacuum	GAG520

# Appendix C – Maintenance Kit

<b>ASP140 – Maintenance Kit – M-15/O<sub>2</sub> and P-20/O<sub>2</sub></b>		
<b>Part Number</b>	<b>Quantity</b>	<b>Description</b>
OXS350	1	Oxygen Concentrator – Replacement Compressor Inlet Filter
OXS356	1	Oxygen Concentrator – Compressor Rebuild Kit
OXS362	1	Oxygen Concentrator – Compressor Pressure Relief Valve
OXS370	1	Oxygen Concentrator – Cover Filter
FA40	1	Filter – Cooling Fan Filter
FLT34	1	Filter – Inline Particulate Filter
ORG10	2	O-Ring – 2” CD Reaction Chamber, Small
ORG110	4	O-Ring – 2” CD Reaction Chamber, Large
FUS20	5	Fuse, Bussmann MDL-5 – 5 amp, 250VAC Slow Blow, Main Power
SV500	1	Solenoid Valve Rebuild Kit – 2 Way
CKV21	1	Check Valve – 1/4" FPT X 1/4" FPT
CKV22	1	Check Valve – 1/4" FPT X 1/4" MPT

<b>ASP156 – Maintenance Kit – CD15/O<sub>2</sub> and CD20/O<sub>2</sub></b>		
<b>Part Number</b>	<b>Quantity</b>	<b>Description</b>
OXS350	1	Oxygen Concentrator – Replacement Compressor Inlet Filter
OXS356	1	Oxygen Concentrator – Compressor Rebuild Kit
OXS362	1	Oxygen Concentrator – Compressor Pressure Relief Valve
OXS370	1	Oxygen Concentrator – Cover Filter
FA40	1	Filter – Cooling Fan Filter
FLT34	1	Filter – Inline Particulate Filter
ORG10	4	O-Ring – 2” CD Reaction Chamber, Small
ORG110	8	O-Ring – 2” CD Reaction Chamber, Large
FUS20	5	Fuse, Bussmann MDL-5 – 5 amp, 250VAC Slow Blow, Main Power
FUS75	2	Fuse, Littelfuse Minifuse 297005 – 5 amp, 32VAC, Drive Board
SV500	1	Solenoid Valve Rebuild Kit – 2 Way
CKV21	1	Check Valve – 1/4" FPT X 1/4" FPT
CKV22	1	Check Valve – 1/4" FPT X 1/4" MPT

# Appendix D – Logic Schematics

## M-15/O<sub>2</sub>, CD15/O<sub>2</sub>, P-20/O<sub>2</sub>, and CD20/O<sub>2</sub> – Overall Electrical

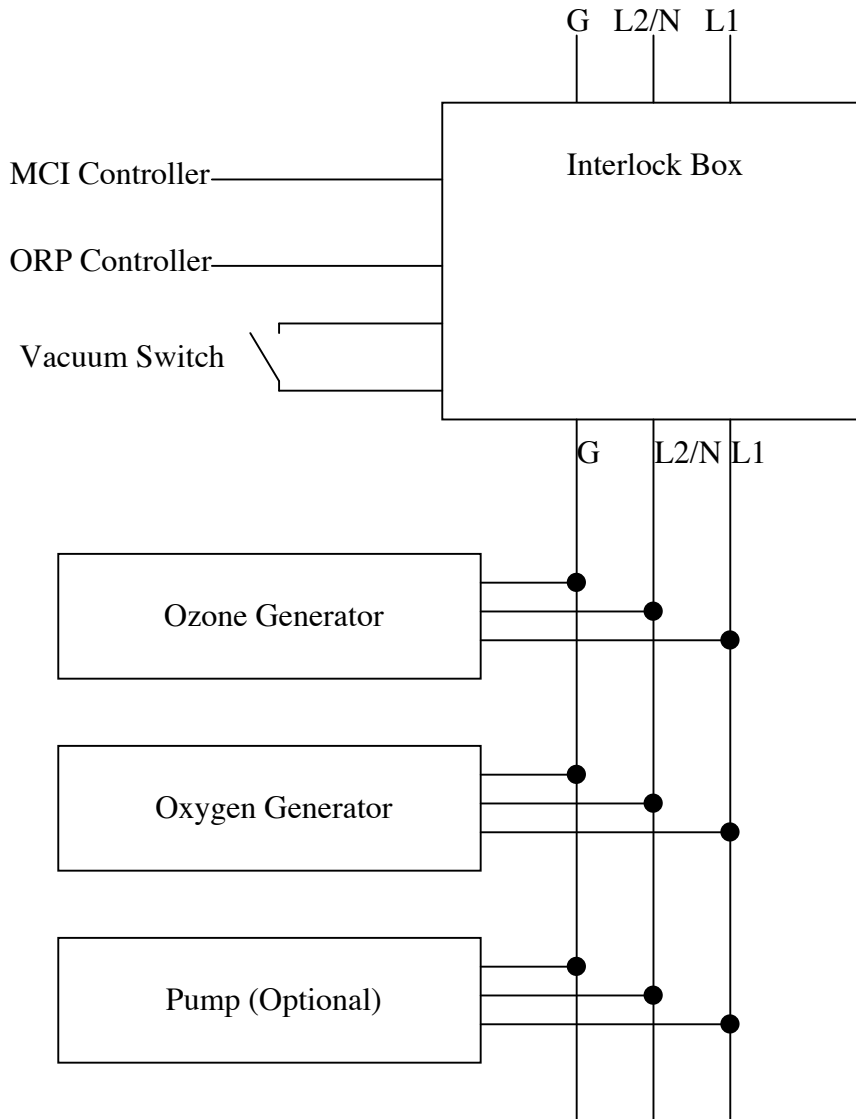

M-15/O<sub>2</sub>– Ozone Generator – M1500

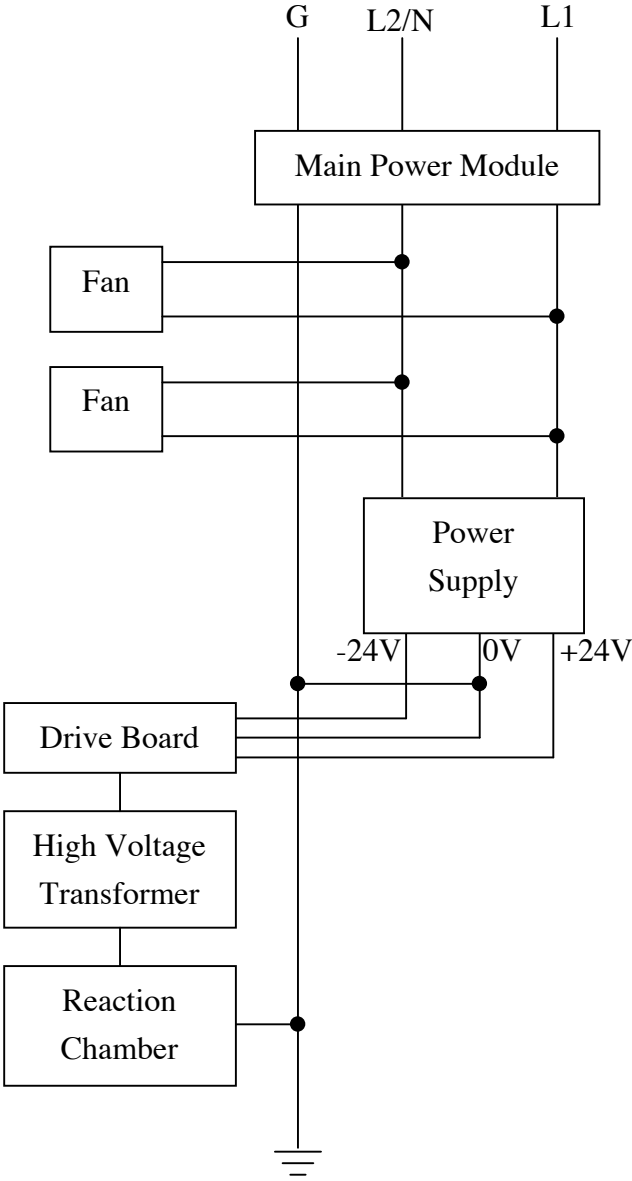

CD15/O<sub>2</sub>– Ozone Generator – CD1500

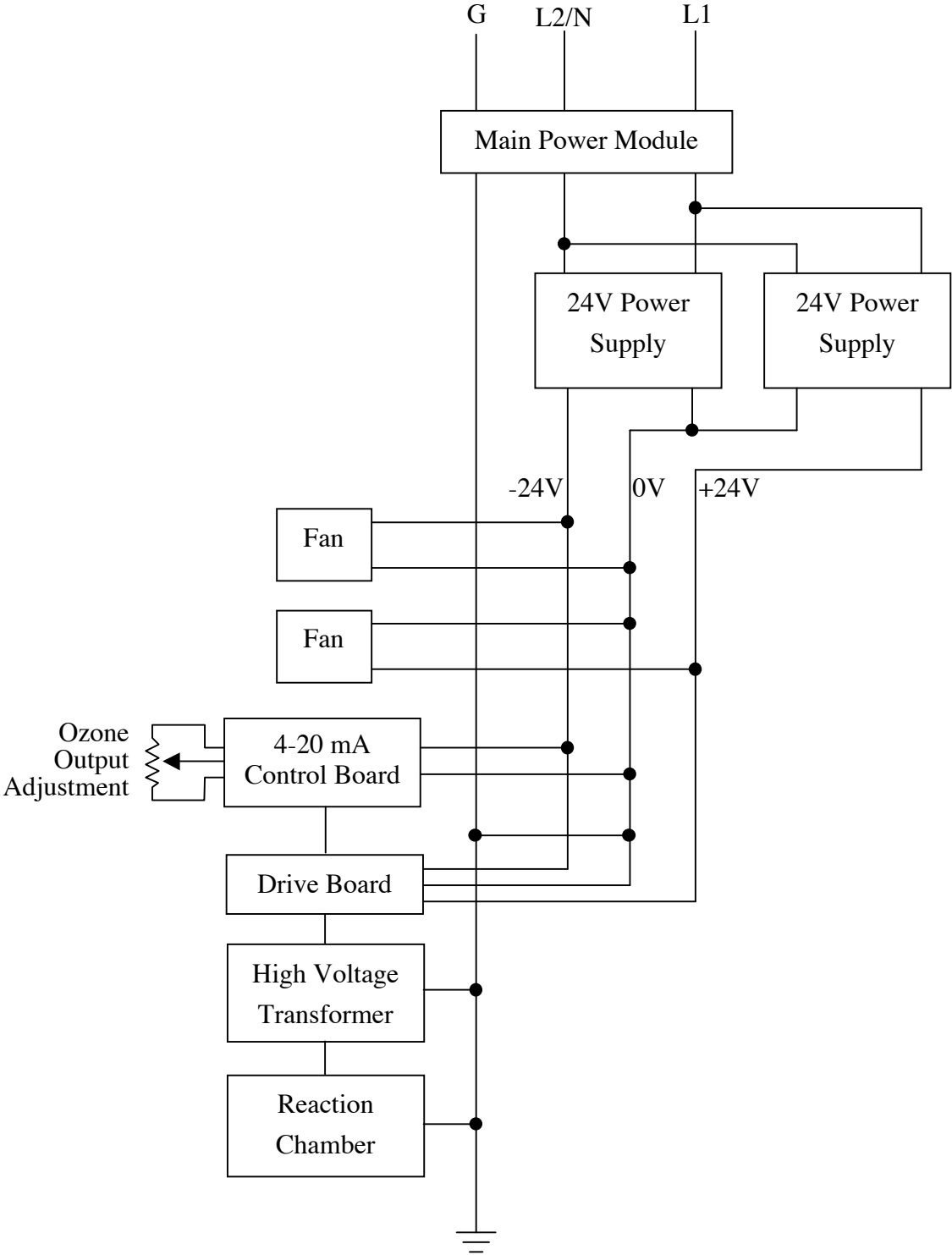

P-20/O<sub>2</sub>– Ozone Generator – P2000

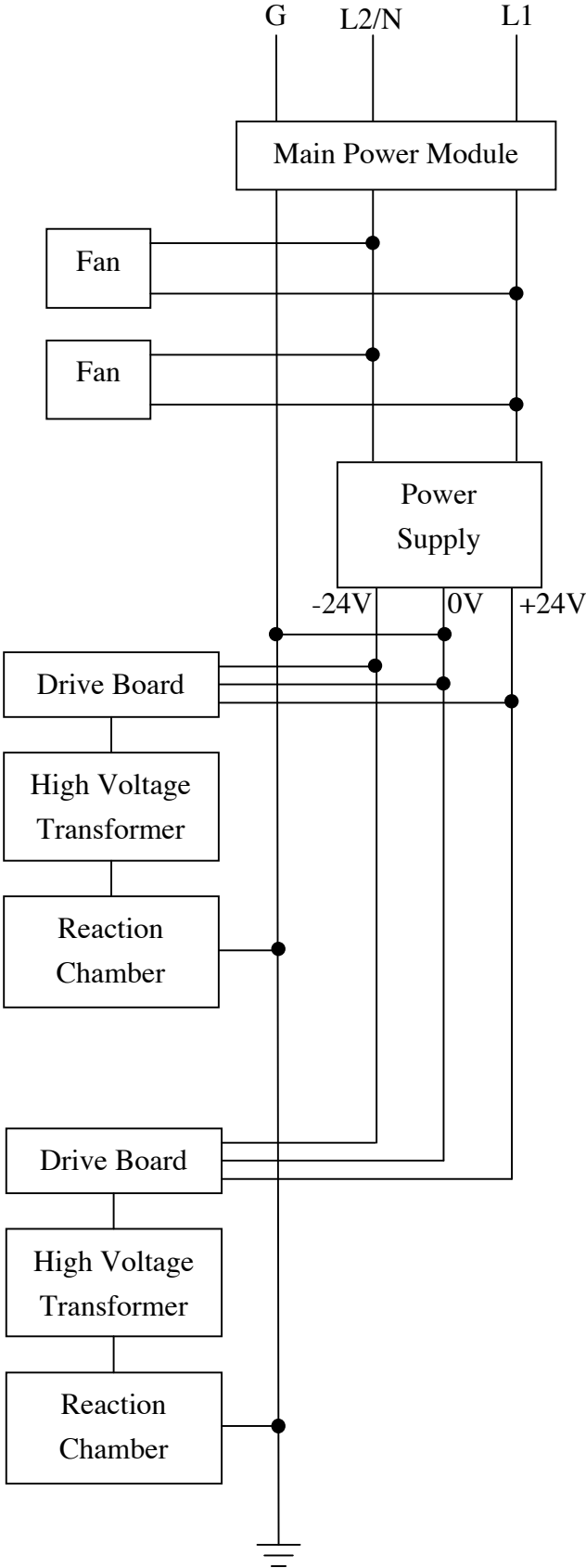

CD20/O<sub>2</sub>– Ozone Generator – CD2000

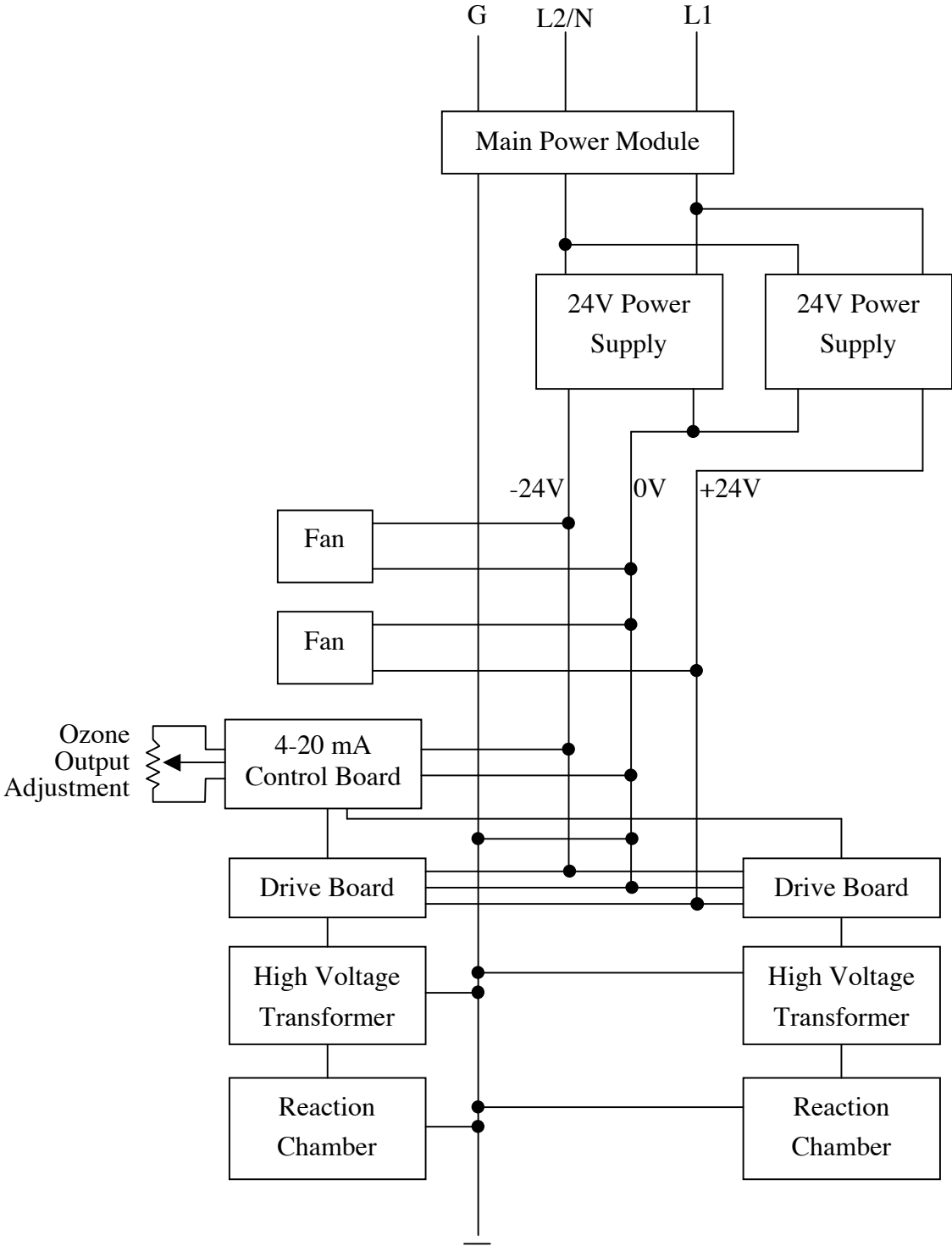

# Appendix E – Drive Module Input

M-15/O<sub>2</sub> and P-20/O<sub>2</sub> – ELPC5100

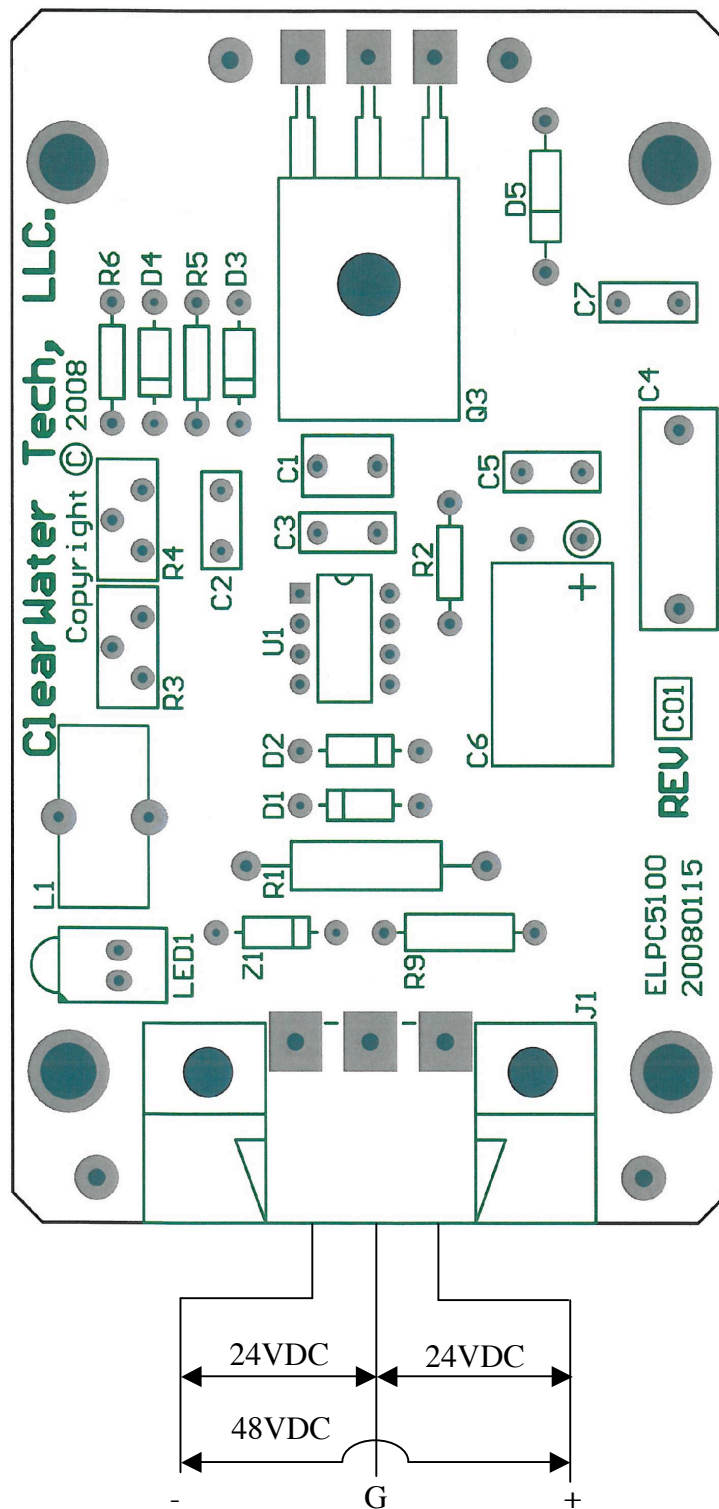



CD15/O2 and CD20/O2 – CCA1231

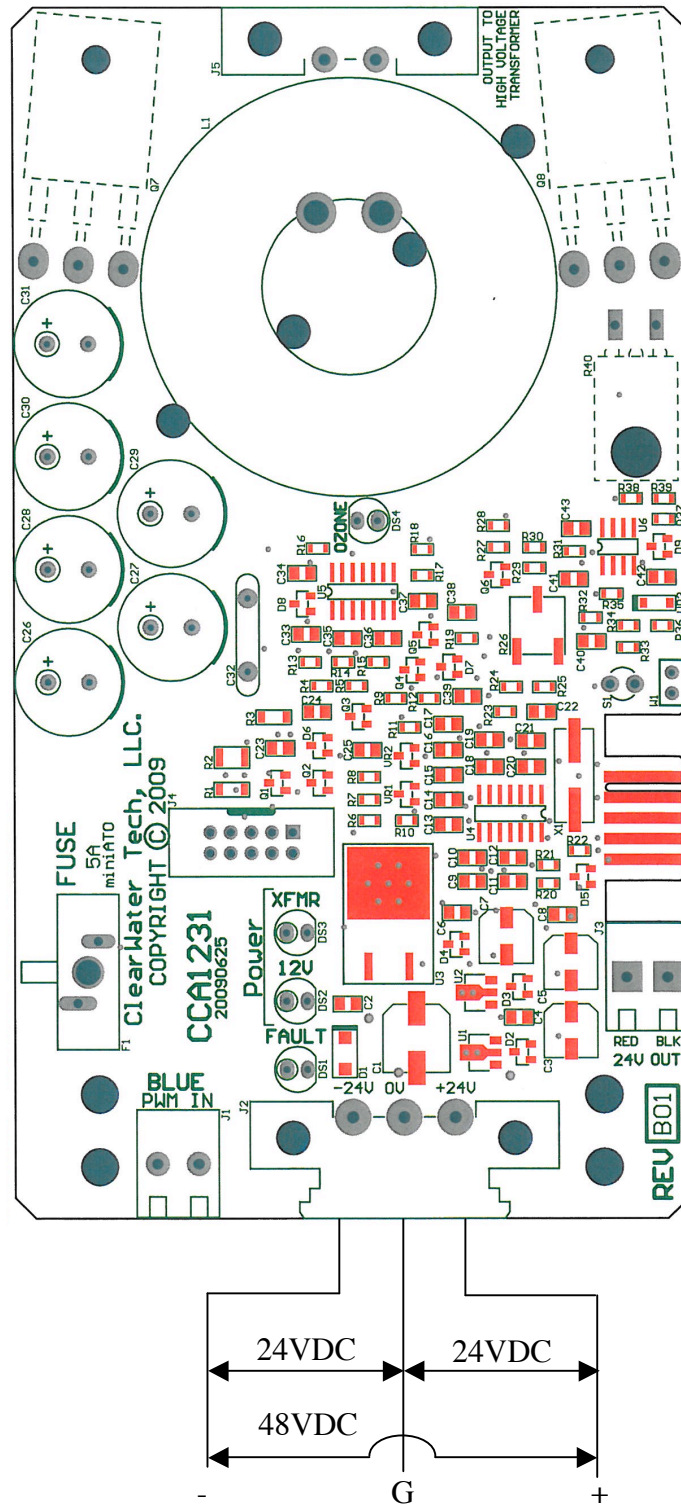

# Appendix F – Warranty Information

## ClearWater Tech, LLC. Limited One-Year Warranty

### Summary of the Warranty

ClearWater Tech, LLC (“CWT”) makes every effort to assure that its products meet high quality and durability standards and warrants the products it manufactures against defects in materials and workmanship for a period of one (1) year, commencing on the date of original shipment from CWT, with the following exceptions: 1) The warranty period shall begin on the installation date if the installation is performed within 90 days of the original shipment from CWT; 2) The warranty period shall begin on the date of the bill of sale to the end user if the installation date is more 90 days after the original shipment date. To validate the warranty, a warranty card, accompanied by a copy of the bill of sale, must be returned to CWT and must include the following information:

- End user name
- Complete address, including telephone number
- Date installed
- Complete model and serial number information
- Name of company from which the unit was purchased

Repairs and replacement parts provided under this warranty shall carry only the unexpired portion of this warranty or 90 days, whichever is longer.

### Items Excluded from the Warranty

This warranty does not extend to any product and/or part from which the factory assigned serial number has been removed or which has been damaged or rendered defective as a result of:

- An accident, misuse, alteration or abuse
- An act of God such as flood, earthquake, hurricane, lightning or other disaster resulting only from the forces of nature
- Normal wear and tear
- Operation outside the usage parameters stated in the product user’s manual
- Use of parts not sold by CWT
- Service or unit modification not authorized by CWT
- Check valve/solenoid valve failure
- Damage which may occur during shipping
- Failure to meet service requirements as outlined in the I & O manual

### Obtaining Service Under the Warranty

Any product and/or part not performing satisfactorily may be returned to CWT for evaluation. A Return Goods Authorization (RGA) number must first be obtained by either calling or writing your local authorized dealer, distributor or CWT direct, prior to shipping the product. The problem experienced with the product and/or part must be clearly described. The RGA number must appear prominently on the exterior of the shipped box(es). The product and/or part must be packaged either in its original packing material or in comparable and suitable packing material, if the original is not available. You are responsible for paying shipping charges to CWT and for any damages to the product and/or part that may occur during shipment. It is recommended that you insure the shipment for the amount you originally paid for the product and/or part.

If, after the product and/or part is returned prepaid and evaluated by CWT, it proves to be defective while under warranty, CWT will, at its election, either repair or replace the defective product and/or part and will return ship at lowest cost transportation prepaid to you except for shipments going outside the 50 states of the United States of America. If upon inspection, it is determined that there is no defect or that the damage to the product and/or part resulted from causes not within the scope of this limited warranty, then you must bear the cost of repair or replacement of damaged product and/or part and all return freight charges. Any unauthorized attempt by the end user to repair CWT manufactured products without prior permission shall void any and all warranties. For service, contact your authorized dealer or distributor or CWT direct at (805) 549-9724.

### Exclusive Warranty

There is no other expressed warranty on CWT products and/or parts. Neither this warranty, nor any other warranty, expressed or implied, including any implied warranties or merchantability of fitness, shall extend beyond the warranty period. Some states do not allow limitation on how long an implied warranty lasts, so that the above limitation or exclusion may not apply to you.

### Disclaimer of Incidental and Consequential Damages

No responsibility is assumed for any incidental or consequential damages; this includes any damage to another product or products resulting from such a defect. Some states do not allow the exclusion or limitation of incidental or consequential damages, so that above limitation or exclusion may not apply to you.

### Legal Remedies of Purchaser

This warranty gives you specific legal rights and you may also have other rights, which vary from state to state.

**THIS STATEMENT OF WARRANTY SUPERSEDES ALL OTHERS PROVIDED TO YOU AT ANY PRIOR TIME.**